



Current and voltage relay testing unit to 250 A
with integrated independent variable voltage channel

User's Manual



PTE-100-C PRO

REFERENCE: FAAVM02PR

EDITION: May 16 th, 2019

VERSION: 7

Quality is the core reference for EuroSMC's activities, aimed to fully satisfy our customers' needs and expectations.

DISCLAIMER

The information, product specifications, and technical data contained in this document imply no contractual binding to EuroSMC's responsibility. The user is the sole responsible for the application of the products mentioned in this document. EuroSMC explicitly exonerates itself from liability to accidents or unwanted results, directly or indirectly derived from mistakes made in the writing of this document. Copying or reproducing all or part of this document is not allowed without the explicit written permission from EuroSMC. Due to continuing development and quality improvements, EuroSMC reserves the right to make changes in their products without notice.

INDEX

PTE-100-C PRO PACKING LIST	6
INTRODUCTION	8
GENERAL OVERVIEW	9
Technology	9
Power Section Design	9
Auxiliary Voltage Supply	10
Measurement and Control	10
The PTE-FCN variable voltage channel	11
DESCRIPTION	12
MAIN AC SUPPLY	12
Main Protection Fuses.....	12
POWER OUTPUT SECTION	13
Output ON/OFF buttons	13
Regulation Variac.....	13
Current output taps	14
0-250 VAC voltage tap (OUT 1)	14
0-350 VDC voltage tap (OUT 2).....	14
Display #2.....	15
Displaying the used output	15
Current tap selection.	16
Power Section Alarms	16
AUXILIARY VOLTAGE	17
Out 3: 0-250 Vdc.....	17
Out 3's Automatic Protections.....	17
Out 4: 110 Vac.....	17
TIMER SECTION	18
Monitor Inputs	18
Time Display	18
Timer control.....	19
Timer start/stop modes	19
SPECIAL FUNCTIONS.....	20
MEASUREMENT FUNCTIONS.....	21
CONTROL FUNCTIONS.....	22

COMMUNICATIONS	23
Serial RS-232 port	23
PTE-BUS.....	23
OPERATION	24
CURRENT AND VOLTAGE INJECTION.....	24
AC Current Injection	24
Overload protection.....	26
Voltage Injection.....	26
AUXILIARY POWER.....	27
Out 3 variable DC auxiliary supply.....	27
Out 4 fixed AC auxiliary supply.....	28
TESTING OPERATION TIME	28
The Monitor Input	30
Timer control.....	30
Pulse Length Measurement.....	31
SPECIAL MEASUREMENT AND CONTROL FUNCTIONS	31
Voltmeter and Frequency Meter	32
Output Current-related Measurements	32
Protecting your relay against test-related accidents	33
Testing Instantaneous Overcurrent	34
Pre-setting a current value.....	36
CALIBRATING THE PTE-100-C PRO	37
Required equipment.....	37
General Calibration Procedure.....	38
SPECIFICATIONS	39
Output Characteristics.....	39
Special Functions.....	39
Meas. functions	40
Voltage Supply	40
Physical Dimensions.....	40
GENERAL DIAGRAM.....	41
FRONT PANEL	42
THE PTE-FCN VOLTAGE MODULE	43
DESCRIPTION.....	43

Powering the PTE-FCN	43
Power output.....	43
BUTTONS AND LEADS.....	44
Alarm indicators.....	45
INTERNAL PROTECTIONS.....	45
POWER-UP STATE	46
Working with the PTE-FCN module.....	46
Adjusting the LCD screen’s contrast.....	46
PTE-FCN TECHNICAL CHARACTERISTICS	47
PTE-FCN FRONT PANEL	48
AFTER SALES SUPPORT	49
WARRANTY	49
CUSTOMER SUPPORT.....	49
OTHER EUROSMEC PRODUCTS	49

PTE-100-C PRO PACKING LIST

1	PTE-100-C unit
1	PTE-FCN module ¹
1	Nylon bag
1	AC supply cord
6	2-meter, 2.5 mm ² section test leads (3 black, 3 red)
2	2-meter, 10 mm ² section test leads (1 black, 1 blue)
1	2-meter RS-232 communications cable to PC
2	6-mm to 4-mm plug adapters
4	Clips up to 50A (2 black, 2 red)
4	Clips up to 10A (2 black, 2 red)
2	5 x 20 mm, 100 mA, FAST fuses
2	5 x 20 mm, 0.5 A, Standard fuses
2	5 x 20 mm, 12,5 A, FAST fuses
2	5 x 20 mm, 16 A, FAST fuses *
2	5 x 20 mm, 20 A, Standard fuses
1	Calibration Software CD-ROM
1	Warranty Registration Form
1	Measurements Certificate
1	This user's manual

*Only with 110 Vac equipments.

¹ Refer to the PTE-FCN VOLTAGE MODULE section at the end of this handbook for details and operation instructions of this add-on.

Module PTE-FCN

1	PTE-FCN Unit
1	AC supply cord
2	Connection cables (1 black, 1 red)
1	Earth wire connection Cable
1	BUS-PTE interconnection Cable
2	5 x 20 mm, 0,75 A Fuses
1	European 0,5 A, FAST Fuse
2	European 1 A, FAST Fuses
2	European 1,25 A, FAST Fuses

INTRODUCTION

The PTE-100-C PRO Relay Test Set is designed to test protective relays based on single-phase current and /or voltage measurement.

Its small size, excellent output power and accuracy, quality features, and ease of use, make this product one of the best choices available in its kind.

To achieve this goal, EUROSMC collected the opinion and suggestions of various professionals and companies of recognized prestige and experience in protective relay maintenance and commissioning. As a result, the PTE-100-C PRO features the following unique characteristics:

- Robust mechanical and electrical construction.
- Great portability.
- Built-in measurement features to avoid carrying a large number of instruments.
- Results printout capability, when taking notes is usually difficult.
- Software-assisted closed-case calibration with a Windows PC.
- Functions to protect the relay being tested.
- Easy, intuitive operation.

The PTE-100-C PRO includes all the accessories needed for testing, such as cables, clips, nylon bag for transport, spare fuses etc. as standard equipment.

We appreciate your suggestions about the PTE-100-C PRO and this manual, in our commitment to improve our quality. Our technical staff will be pleased to help you on any difficulties or questions that you may have.

Thank you for choosing EuroSMC products.

EUROSMC, S.A.
Pol. Ind. P-29 Calle Buriel 69
28400 Collado Villalba. MADRID (SPAIN)
TEL: 34-91-91 849 89 80. FAX: 34-91-851 25 53
www.smcint.com

GENERAL OVERVIEW

Technology

The PTE-100-C PRO combines state-of-the-art digital technology with the traditional regulation method based on a variable autotransformer and transformer.

Analogue and digital electronics convert signals in- and out from the unit in order to be processed and displayed by an 8-bit microprocessor.

The power section is based mainly on electromechanical components.

The unit's layout is arranged in modules and the number of moving parts is kept to a minimum for easy and safe operation.

Power Section Design

Classical, direct regulation and transformers are used to generate and control the high 1,000-VA power output, as shown in the following diagram:

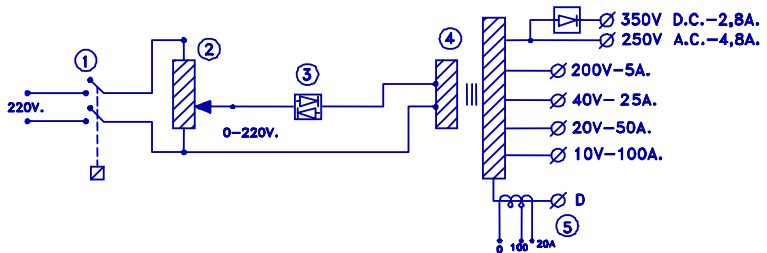

1. An internal relay connects the main power supply to the variac under no-load conditions.
2. The single-phase variable autotransformer (Variac) regulates the voltage at the primary winding of the output power transformer.
3. A static switch (Triac) guarantees a clean connection and disconnection of the Variac from the power transformer's input.
4. A toroidal transformer guarantees the insulation of the output from the main power supply.
5. A current measurement transformer, with one primary winding and two secondaries with 250:1 and 50:1 respective ratios, is con-

ected to the 'zero' output tap of the power transformer. Measurement range switching is automatic.

Auxiliary Voltage Supply

By means of a transformer with multiple secondary windings, the PTE-100-C PRO features two independent auxiliary voltage outputs:

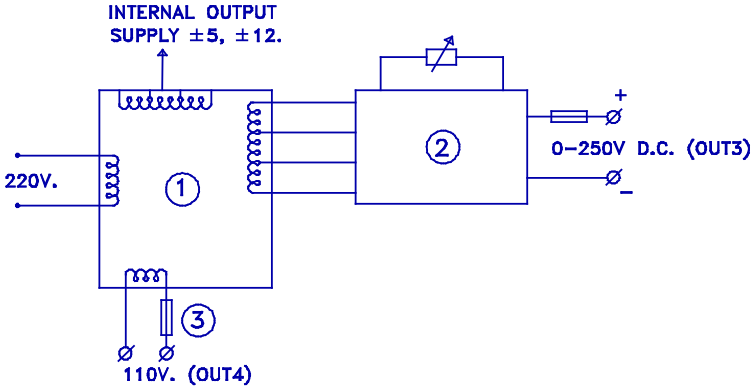

- Out 3 is a variable 0-250 VDC stabilized, electronically protected supply with a dedicated ON/OFF switch, and
- Out 4 is a fixed 110 VAC. This fuse-protected output is permanently active whenever the equipment is switched on.

Measurement and Control

Analogue input is converted to digital values before it is processed and displayed. The following external or internal analogue magnitudes are measured:

- Voltage.
- Current.
- Phase angle.
- Temperature.

Displayed and/or used values like Impedance or Power are automatically calculated from these magnitudes by the microcontroller.

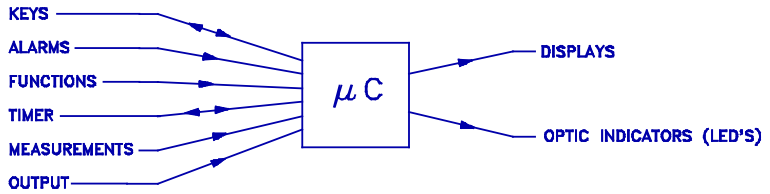

The same micro-controller processes all the user's control actions like output on/off, the timer activation, the selection and display of function values, and the protective alarms.

The PTE-FCN variable voltage channel

This add-on, installed inside the PTE-100-C PRO's lid, provides an additional voltage source that is variable in amplitude, frequency and phase angle. The PTE-FCN module is an efficient, accurate and stable amplifier-based voltage source that provides a high quality output.



The PTE-FCN must be powered from the built-in fixed 110 VAC auxiliary output of the PTE-100-C PRO only. Use the supplied razor-type bipolar cord for this purpose. The use of any other source to power the PTE-FCN module can permanently damage it and is not covered by the warranty.

Using the PTE-FCN's variable voltage output in combination with the variac-regulated power channel of the PTE-100-C PRO, you can test directional relays, distance / impedance relays, synchronism and frequency relays, among many others.

Refer to the "PTE-FCN" chapter at the end of this manual for instructions how to use the independent variable voltage channel.

DESCRIPTION

All the elements in the front panel of the PTE-100-C PRO are thoroughly described here. In-depth explanation of their use is given in the Operation section.

Many buttons, namely those that perform a different function when held down, effectively actuate when released, rather than when pressed. These buttons will produce a “secondary function” when pressed until an audible beep is heard.

We will now describe the PTE-100-C PRO along the following sections:

MAIN AC SUPPLY

POWER OUTPUT SECTION

AUXILIARY VOLTAGE

TIMER SECTION

SPECIAL FUNCTIONS

COMMUNICATIONS

MAIN AC SUPPLY



An AC supply block at the lower left-hand corner of the front panel groups the power cord plug, a fuse holder and the main on/off switch. Internal filters prevent most AC perturbations from leaking into the unit. The OFF position is indicated by a tiny circle in one of the faces of the main switch.

Main Protection Fuses

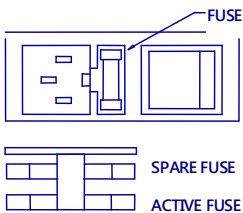

The active (12A, Fast) fuse and a spare fuse are included in the fuse holder. All the fuses accessible from the front panel are standard, 5x20 mm cylindrical, and their current rating and type are clearly printed.



REPLACE BLOWN FUSES WITH IDENTICAL ONES ONLY. DAMAGE RESULTING FROM INCORRECT FUSE REPLACEMENT IS NOT COVERED BY THE WARRANTY.

POWER OUTPUT SECTION

This is the right-hand section of the front panel. It contains the main output control buttons, the regulation *variac*, the Display #2, the current and voltage output taps, the tap selector, the displayed output selector and a few associated and alarm LEDs:



Output ON/OFF buttons

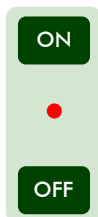

These buttons connect and disconnect the main power output, i.e. the current output taps and the *Out 1* and *Out 2* voltage taps. A red LED indicates the following output states:

OFF: The output has been intentionally switched off

ON: The output has been intentionally switched on

BLINK: The output has been switched off by the unit. This will be further explained under the OPERATION section.

Regulation Variac

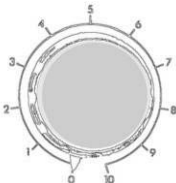

This knob controls the output level of the current and voltage power taps. The numerical 0-10 round scale is provided as a positional reference only. The actual output level is shown in Display #2 and, at any given regulator position, its value always depends on the connected impedance. Regardless of the regulator's position, no power will be output when the output control switch is OFF. Always handle this regulator with care.



A harmful amount of current could be injected into the connected load if you accidentally switch the output ON with the variac in a position other than zero.

Current output taps

At the top of the power output section, four current injection taps are provided to adapt the current output characteristics to the connected load, as well as to facilitate the output level regulation.

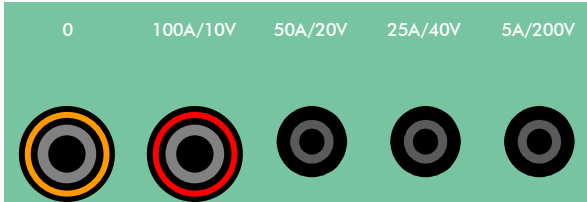

provided to adapt the current output characteristics to the connected load, as well as to facilitate the output level regulation.

Tap zero is the common reference. If you are testing with currents ranging from 0 to 50 A AC, for example, connect the load between the common tap and the tap labeled "50 A / 20 V". If you are using 4 mm bananas, you will need the supplied 6-mm to 4-mm plug adapters for the common tap and the 100 A tap.



Press these adapters all the way down before pulling them up for removal.



0-250 VAC voltage tap (OUT 1)

Out 1 is located on the left immediately underneath the variac knob. Output from this tap is measured and regulated in AC volts. Maximum throughput current is 4A in non-continuous service.



0-350 VDC voltage tap (OUT 2)

Out 2 is located on the right of Out 1. Its output is measured and regulated in DC volts. Polarity is indicated by the black (negative) and red (positive) plug colors.

A standard 19 mm plug can be used with this pair of connectors. All these taps and connectors comply to the latest international standards and electrical safety regulations.

Display #2

All the PTE-100-C PRO output magnitudes are shown on Display #2, located above the variac's knob:



The units in which the various possible readings are represented are labeled on the right edge of this LED display:

INDICATORS	UNITS
A	Current in Amps.
V	Voltage in Volts.
%	Percentage of the nominal current.

The following measurements can be read on this display:

- Output current in Amperes.
- AC or DC voltage present in Out 1 or Out 2 power taps and also in Out 3 auxiliary DC voltage tap (regulated independently).
- Percentage of the 'nominal' current value entered in Display #1 by means of the "%" special function.

The floating decimal point is automatically placed to accommodate the reading to the working regulation range.

Displaying the used output

Variable output magnitudes are shown in Display #2, used as an ammeter by default. Since there are several output taps but only one display, you need to select the tap to be displayed by pressing the corresponding *display assignment* buttons:

Out 1

Press this button to view the voltage present in *Out 1* (variable 0-250 VAC).

Out 2

Press this button to view the voltage present in *Out 2* (variable 0-350 VDC).

Out 3

Press this button to view the voltage present in *Out 3* (auxiliary variable 0-250 VDC). *Out 3*, located in the center section of the PTE-100-C PRO panel, is switched on, regulated and protected independently from the other outputs.

A green LED above its tap will identify the displayed output. If you want to lock the Display #2 to Out1, Out2 or Out3, press the corresponding display selection button and hold it for 5 seconds until you hear a beep. To return to the normal ammeter function, give a brief press to any of these buttons.

Current tap selection.

Tap

The PTE-100-C PRO cannot detect which of the current taps is connected the load to. Though the current value shown by Display #2 is common to the four taps, some special functions, overload protections and calculations require that the current output tap to which the load is actually connected is identified to the unit. Press this key to sequentially signal the 100 A, 50 A, 25 A or 5 A tap in use.

Though this will not affect the output current nor the value shown in Display #2, we strongly recommend you to do it whenever you move your connections to a different current output.

Power Section Alarms

The PTE-100-C PRO's power section is protected from over-heating and from overload. These conditions will automatically switch the power output off and will be signaled by these two orange-colored 3-mm LEDs:

- **I Therm.** An internal sensor will protect the unit from overheating. This alarm automatically disappears when the unit cools down to normal temperature. Operation can then be resumed.
- **I Lim.** This protection operates when the upper limit of the selected current tap, or the limit optionally set with the "Ilim" special function, whichever is lowest, has been exceeded.



Up to 250 A can be attained from the 100A/10V tap for 3 seconds before the unit's thermal protection trips. Refer to the duty cycle chart in the CURRENT AND VOLTAGE INJECTION chapter to learn more on how to get currents higher than 100 A from this tap.

AUXILIARY VOLTAGE

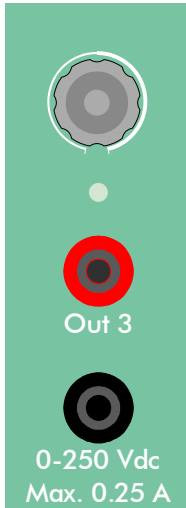

Auxiliary Outputs are intended as general purpose voltage supplies, rather than actual power sources. These outputs are also galvanically isolated from each other and from the main power supply.

Out 3: 0-250 Vdc

Out 3 is located on the center section of the front panel. Polarity of this d. c. output is color-coded in its 4 mm connectors: black (negative) and red (positive).

This auxiliary output has its own regulation knob and an ON/OFF button with a red LED that will lit when the output is active.

Out 3's Automatic Protections

An orange-color LED will blink and the output will be suspended while *Out 3* is short-circuited. In case of overheating, the LED will be lit steadily. Both alarms will be cleared and the output will be automatically resumed when conditions return to normal.

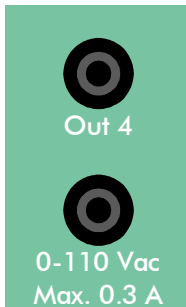

Out 4: 110 Vac

Out 4, the fixed 110V AC auxiliary output located next to the AC supply block, is active whenever the unit is switched on.

Out 3 and *Out 4* are protected by two 5x20 mm, 0.5 A fuses located on the left side of the AC supply block. To open the fuse holder, press and turn 90° anti-clockwise with a small screwdriver.



REPLACE BLOWN FUSES WITH IDENTICAL ONES ONLY. DAMAGE RESULTING FROM INCORRECT FUSE REPLACEMENT IS NOT COVERED BY THE WARRANTY

TIMER SECTION

The PTE-100-C PRO's digital Timer display is located on the left hand section of the front panel, along with its control buttons and status LEDs.

Monitor Inputs

Tested relay's operation is detected by means of two inputs:

1. A BLACK/GREEN input for dry (non-energized) contact monitoring, and
2. A BLACK/RED input for voltage signals of up to 250 Vac/dc maximum.



Both inputs are protected by 0.1 A FAST type 5x20 mm. fuses. Press and turn the fuse holder 90° counter clockwise to replace a blown fuse.



REPLACE BLOWN FUSES WITH IDENTICAL ONES ONLY. DAMAGE RESULTING FROM INCORRECT FUSE REPLACEMENT IS NOT COVERED BY THE WARRANTY

Time Display

Time values resulting from tests are shown in Display #1 with a maximum resolution of 1 millisecond.



Display #1 is a multi-function display. Besides time values in seconds or cycles of the AC supply line, it can show various measurement units that are automatically labeled at its right hand edge:

SYMBOLS	UNITS
S	Seconds.
CY	Cycles of the main AC supply line.
Hz	Hertz (Frequency)
V	Volts in a.c. (steady) or d.c. (flashing)
O	Phase Angle Degrees.
Ω	Ohms
VA	Power in Volt amperes
A	Amperes

The floating decimal point is automatically placed to accommodate the reading to the working measurement range's accuracy.

Timer control

The following buttons are used to control the PTE-100-C PRO's timer operation and various start/stop logics:

Mode

Successive presses of this button change the *start* and *stop* modes of the timer. The various options are represented by different combinations of the *START* and *STOP* LEDs on the left side of the button. Refer to the *Timer Start and Stop Modes* section below.

Display

Use this button to toggle the displayed time between seconds and cycles (of the power line's frequency).

Reset

This button returns the timer to zero and re-enables the automatic power shut off. Injection will not stop automatically upon relay operation if the timer is not previously reset. Please refer to the *Operation* section for a more in-depth description of this feature.

Timer start/stop modes

You can adapt yourself to different timing conditions by setting up the various combinations of start and stop events for the PTE-100-C PRO's timer. The default combination –first and third LEDs- sets the timer to start when the current or voltage output are connected and to stop when operation is detected at the monitor's dry or wet contact inputs. Use the *MODE* button to toggle between the available combinations:

Function

Once in the *functions* mode, press this button briefly to go down to the next function. You cannot back up. Measurement functions display a steady LED and control functions display a flashing LED. In measurement functions, press and hold this button for 5 seconds to access a secondary measurement mode. Refer to the Operation section for a detailed description of each function.



Control functions (for example, *injected current limit*) require numerical input. Use these buttons to enter a value in Display #1.



If you press and hold both buttons for 5 seconds or more while in the normal *Ch.* mode, the serial RS-232 communications port will be activated, enabling the connection of a printer or a computer as explained later.

Enter/Print

Use this button to confirm entered values or to activate/deactivate control functions.

While in the normal *Ch.* Mode, it will print the displayed values to a connected serial printer.

These are the available functions in *Func.* mode:

MEASUREMENT FUNCTIONS

	<u>Normal measurement</u>	<u>Secondary measurement</u>
● Vmon	AC or DC voltage at the monitor's BLACK/RED input	Mains AC voltage
● Fmon	Frequency at the monitor's BLACK/RED input in Hertz	Mains AC frequency
● Vtap	AC Voltage at the used current tap in Volts	NONE
● Ztap	Impedance connected at the used current tap in Ohms. Press ENTER to store the measured value in memory (read <i>Preset</i> function below)	4-wire Impedance at the used current tap (voltage is measured at BLACK/RED monitor input)

● φ	Angle of the impedance connected to the used current tap, in 0-360 degree notation	Angle between the injected current and the voltage present at the BLACK/RED monitor input
● S	Apparent power at the used current tap in VAs	Apparent power at the used current tap in VAs, reading voltage drop at the BLACK/RED monitor input

CONTROL FUNCTIONS

	<u>Description</u>	<u>Usage</u>
● %	Percentage regulation mode. Display #2 will show a percent value rather than Amperes.	Set the nominal current value in Display #1 and activate/deactivate with ENTER
● I _{max}	Peak current ammeter mode. Display #2 will show the maximum injected current.	Select the function and use ENTER to activate / deactivate.
● I _{lim}	Current limit. Protect the tested device against accidental overcurrent.	Set the maximum allowed current in Display #1 and activate/deactivate the protection with ENTER
● T _{lim}	Time limit. Protect the tested device against accidental overheating.	Set the time limit in Display #1 and activate/deactivate the protection with ENTER
● Preset	Adjust a current value in Display #2 using the variac before switching the output on.	Activate / deactivate with ENTER. The load's impedance must be previously stored using the Z function.

COMMUNICATIONS

The PTE-100-C PRO features two different means of communicating with other equipment: standard RS-232 and EuroSMC's proprietary PTE-BUS communications. Both connectors are located on the center of the front panel above the EuroSMC logo.

Serial RS-232 port

This standard DB-9 male connector is compatible with common serial devices such as printers, data terminals and computers. Following is the RS-232 pinout:

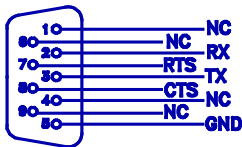

RS-232

1,4,6,9: NC	Not connected
5: GND	Earth ground
2: RX	Input DATA
3: TX	Transmitted DATA
7: RTS	Output - Ready to Send
8: CTS	Input - Clear to Send

The unit is supplied with the appropriate cable for connection to a serial printer or to a computer.

PTE-BUS

The PTE-100-C PRO can be used in combination to other EuroSMC's products over this special, high-speed applications bus, in order to extend their capabilities. Thanks to this advanced concept of modularity, the user can interconnect two or more PTE units to build a sophisticated test platform that is more powerful and capable than the individual sets used, whenever complex relay testing or assistance from a computer is required.

When the PTE-100-C PRO is used stand-alone, the PTE-BUS provides the necessary communications between the main PTE-100-C unit and the PTE-FCN independent voltage module in the lid, which also has its corresponding PTE-BUS connector. Use the supplied ribbon connection to make the link.

OPERATION

As a test instrument, you basically use the PTE-100-C PRO to adjust and apply some electrical magnitudes to the tested device and to measure its response time or other test results. Directions to use the features described in the previous section are given here.



DO NOT USE THE PTE-100-C PRO FOR REAL TESTING BEFORE READING AND FULLY UNDERSTANDING THIS SECTION.

CURRENT AND VOLTAGE INJECTION

You inject AC current into a load by applying AC voltage to it. Some tests require current (Amperes) regulation and other require voltage (Volts) regulation.

The various power outputs have been designed and built into the PTE-100-C PRO with these test requirements in mind. Therefore, to perform a *current* test, the receiver must be connected to the appropriate current tap and regulation must be done in Amperes. This is the default operation mode of the PTE-100-C PRO. Conversely, for *voltage* tests, we will connect the test object to *Out 1* or *Out 2* and will set the Display #2 to voltage reading by means of the corresponding *display assignment* button.

In any case, the electrical magnitudes to which the tested device is exposed depend on the following factors:

- 1) the used output
- 2) the variac's position
- 3) the connected impedance

AC Current Injection

To inject AC current, follow these steps:

1. Turn the *variac* knob to its leftmost position dialed "0".



A harmful amount of current could be injected into the connected load if you accidentally switch the output ON with the variac in a position other than zero.



2. Connect the receptor's input between the common ("0") and the current output tap that best accommodates the needed test range.

Always use the appropriate current range tap. This will keep distortion to a minimum and will make regulation easier.

3. Use the  button to identify the used tap to the instrument.



The PTE-100-C PRO does not detect the current tap you are using, unless you 'flag' it using the TAP button. Some measurement and protective functions will not work if the green LED under the used tap is not lit.

4. Disconnect any unneeded cables from the unit.
5. Press  briefly and release to ensure that *current* taps, rather than *voltage* taps, are selected for display. The "A" indicator should lit at the right edge of Display #2.
6. Press the  button to switch the output on. Its red LED will lit and some non-zero reading will be shown in Display #2, unless you have left the output circuit open.

Display #2 needs about 2 seconds to stabilize itself. The decimal point will be automatically placed to the biggest accuracy possible for the selected output.



All the power current and voltage outputs are energized when you switch the injection ON, even though Display #2 shows ZERO. Likewise, the voltage present in each tap depends directly on the knob's position. You cannot regulate each tap independently.

Regulate the injected current turning the *variac* knob gently while you observe Display #2.

If you want to use percentage regulation, set a nominal value in Display #1 using the "%" function and activate the percentage mode pressing .

If you want to know the *voltage* present at the selected current tap, activate the **Vtap** function to have it shown on Display #1.

If more than one current or voltage tap is connected to a receiver, the readings at Display #2 will be meaningless.

Overload protection

If injected current exceeds by more than 10% the limit printed above the used tap, the output will be stopped automatically. The ON/OFF LED will then blink and the maximum output current value (or percentage) will be held in Display #2. With the 100A/10V Current Tap, however, this protection is timed inversely to the amount of excess, according to the table below. Maximum current allowed through this tap is roughly 250 Amps.

Output Current	Maximum Injection Time
<110A	Until Thermal Overload Alarm Trips.
110 To 150A	10 Seconds.
150 To 210A	5 Seconds.
210 To 250A	3 Seconds.
>250A	Immediate Trip by I lim Alarm.

Voltage Injection

The procedure is identical to current injection with only a few exceptions:

1. Connect your relay's voltage input to Out 1 (AC voltage) or Out 2 (DC voltage) as required.
2. Have the appropriate tap (Out 1 or Out 2) shown in Display #2 by pressing and holding the **Out 1** or **Out 2** buttons until you hear a beep.

The **Tap** button is irrelevant now because we are using the voltage outputs only.



All the power current and voltage outputs are energized when you switch the injection ON, even though Display #2 shows ZERO. Likewise, the voltage present in each tap depends directly on the knob's position. You cannot regulate each tap independently.

AUXILIARY POWER

Auxiliary power is commonly intended to energize the devices under test, or to polarize electrical reference components, rather than for actual injection of test magnitudes. Auxiliary electronics are not dimensioned nor calculated for big power values. The PTE-100-C PRO features two auxiliary voltage outputs: one variable 0-250 VDC (*Out 3*) and one fixed 110 VAC voltage (*Out 4*).

The most important differences between these outputs and the test outputs (current taps, voltage output 1, and voltage output 2) are:

- *Out 3* and *Out 4* are completely independent from each other and from the power current and voltage *Out 1* and *Out 2* taps.
- *Out 3* and *Out 4* are not automatically shut off during the test procedure.
- Timer operation is not directly affected by these auxiliary outputs.

Out 3 variable DC auxiliary supply

Out 3 is a variable 0-250 V stabilized DC supply. This means that its output level greatly withstands fluctuations at the mains supply and at the power outputs. *Out 3* is protected by a dedicated fuse and an electronic protection against short circuits and overloads. Before connecting any device to *Out 3*, do the following:

1. Press **Out 3** and hold until you hear a beep. The green LED under its small regulation knob will lit. This will bind Display #2 to this output.
2. Turn the small regulation knob all the way counter clockwise to set it to the minimum position.
3. Activate *Out 3*'s output pressing **ON** briefly. The associated red LED will lit.
4. Adjust the required DC voltage level shown in Display #2 and set the output back off pressing **ON** again.

5. Connect the device to be energized to the black (-)/red (+) taps according to the device's polarity and restore the output pressing **ON** again.
6. Check the level again on Display #2 and readjust if required.
7. You can now press **Out 3** briefly again to re-assign Display #2 to its default current output reading. This will not affect the voltage output from Out 3.

Out 4 fixed AC auxiliary supply

This 110 V fixed AC supply is often used to energize some relays and as a phase reference for various test procedures. *Out 4* is also used to supply power to the PTE-FCN module installed in the equipment's lid, and is protected by the fuse labeled "OUT 4".



110 V AC are present in Out 4 whenever the unit is switched ON

TESTING OPERATION TIME

Relay testing is usually as simple as simulating electrical fault conditions at the relay's input, assessing operation and measuring its operation time. This takes an accurate timer that starts when the power output is initiated and stops when the relay *trips*, i.e., its output contact closes. The power output will be stopped automatically upon tripping, too, and the applied current or voltage and resulting operation time will be displayed and hold by Display #2 and Display #1 respectively. This is how the PTE-100-C PRO works essentially.

So these are the basic steps for a *time* test:

1. Switch the PTE-100-C PRO's power output **OFF** and turn the variac all the way to the left to reach the "0" position.
2. Connect the relay's measurement input (to where the CT or VT output is normally connected) to the appropriate current or voltage output tap.
3. If you are doing a *current* based test, choose the current tap that better accommodates the regulation range, turn its 'flag' LED on using the **Tap** key and give a short press to **Out 1** to ensure that current, rather than voltage output, is displayed in Display #2.
If you are using a voltage output instead, press and hold **Out 1** or **Out 2** accordingly until a beep is heard to lock it to Display #2.
4. Connect the relay's trip contact to the PTE-100-C PRO's dry (black/green) monitor input. This is for *dry* contact monitoring. If you are detecting relay operation by means of a contact that is under voltage, use the black and red connectors instead.
5. Switch the power output **ON** and gently turn the variac clockwise until the desired test value is displayed.
6. Switch power **OFF**, **RESET** the timer and power **ON** again to start the test. If the adjusted test value is in the operating range of the relay, it will eventually trip at the monitor input, the timer will stop and the power output to the relay will be suspended (note that the red output LED is now blinking).
7. You will then be able to write down the values held by Display #1 (time) and Display #2 (operating voltage or current). Repeat steps 5 thru 6 for as many different current or voltage test values you need to time.

The Monitor Input

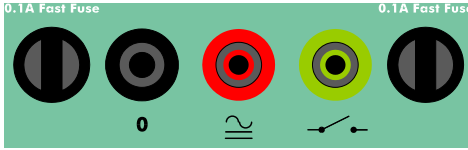

In its most typical implementation, a relay is said to *operate* when, upon detection of a fault, it closes its output contact to trip a circuit breaker, thus clearing the fault. The PTE-100-C PRO will simulate the presence of a circuit breaker by means of its *trip monitor*, that will automatically stop both the timer *and* the power output when the relay operates, thus completing the *fault clearance cycle*.

The monitor will only stop the injection and the timer if it is



connected to the relay's output and you have pressed the

RESET

button before switching the output on.

Monitor *activation* is signaled by a red LED labeled *Monitor* at the left edge of Display #1. This takes place when –



- a) some voltage within the 3 to 250 V AC or DC range drops between the BLACK / RED monitor taps, or
- b) a *dry contact* (the most common case) closes between the BLACK / GREEN monitor taps. This input is protected by a dedicated fuse that will blow immediately if any voltage is applied.



REPLACE BLOWN FUSES WITH IDENTICAL ONES ONLY. DAMAGE RESULTING FROM INCORRECT FUSE REPLACEMENT IS NOT COVERED BY THE WARRANTY

Timer control

As commented above, the timer will start when you activate the power output and will stop when the Monitor is activated. This is the timer's default start/stop mode, but you have more options that correspond to the various combinations of the green *event LEDs* at the left of Display #1. To understand timer modes, we need to distinguish between *positive* and *negative events*:



- Activating the power output, closing a monitored contact or detecting a voltage drop are *positive* events. Positive events are labeled with an *upward* () arrow.
- Automatic disconnection of the power output, opening a closed contact or clearing an existing voltage at the monitor inputs are *negative* events. These are labeled with a *downward* () arrow.

A wide choice of combinations between positive and negative events provide great freedom to accommodate various test conditions and relay types by selecting the class of event that must start or stop the instrument's timer or the power output. If, for example, the operation contact of the tested relay is connected to a circuit under voltage, you can connect it in parallel to the black and red monitor connectors and select a *negative* event for the timer's STOP mode, since any voltage present between these connectors will disappear when the contact is closed upon relay's operation.

Mode

You only need to press the  button sequentially to toggle among the timer's various START/STOP event combinations.

Pulse Length Measurement

Timer *start* is usually associated with some action on the power output switch, but an additional special mode allows the timer to be started *and* stopped when monitor changes occur. This is the *pulse length* measurement mode, with two options: *positive* and *negative* pulse. Select *positive* () pulse to measure the time lapse between activation and deactivation of the monitor. Select *negative* () pulse to measure between the deactivation and re-activation of the monitor.

Remember: monitor activation is signaled by the red LED labeled "Monitor" on the left of Display # 1.

SPECIAL MEASUREMENT AND CONTROL FUNCTIONS

A number of convenience features have been built into the PTE-100-C PRO to make its operation easier, sometimes saving the user from carrying additional instrumentation.



Access to these functions is located in a shaded area underneath Display # 1, which is used to view measured values and to enter control settings.

Press the  button to toggle between *Ch.* (*chrono*) to *Func.* (*function*) mode. The contents of Display #1 will change from timer readings to function-related readings and vice versa when you set back and forth from nor-

mal mode to function mode. Now, press the  button briefly to navigate sequentially throughout the functions list. The first 6 functions in the list (from *Vmon* to *S*) are *measurement* functions, and the remaining 5 (from *%* to *Preset*) are *control* functions, used to modify the default operation of some PTE-100-C PRO's features.

Voltmeter and Frequency Meter

If you need to measure the voltage or the frequency of an external source between 0 to 300 Vac or 400 Vdc, proceed as follows:





- 1) Enter the *Func.* Mode by pressing the  button and press the  button repeatedly until the green LED near *Vmon* is lit.
- 2) Apply the voltage that you want to measure between the BLACK and RED connectors of the Monitor Input. The value will be shown in Display #1 with a "V" at its right edge, which will blink for DC voltage.
- 3) If you are measuring AC, press  once to jump to *Fmon* and see the frequency in Hertz.

If, rather than an external signal, you want to perform these measurements on the unit's AC supply line, press and hold the  while in the above mentioned functions until you heard a beep to activate (and further deactivate) their *secondary* measurement mode.

Output Current-related Measurements

The injected current quantity is shown on the Display #2 during the tests, but you can also obtain several useful measurements related to the connected load and its nature on Display #1, such as applied voltage, impedance's modulus, impedance's angle and apparent power.

To read the *voltage applied* to the load while you are injecting current, do the following:

- 1) Toggle to *Func.* mode using the  button and press  as necessary to navigate to *Vtap*.
- 2) Connect the load to an appropriate current tap and flag this tap using the  button, if not yet done. Check that the variac is in its minimum ("0") position now.
- 3) Press the  button to activate the output and turn the variac gently clockwise to regulate the current injection to the desired value on the Display #2. The applied voltage will be shown at Display #1 simultaneously.



To measure the *impedance* of the connected load, follow the same steps as above but use the */Z|tap* this time. The connected impedance's modulus will be shown in Display #1. For greater accuracy, this measurement can be done following the 4-wire method using the *secondary* mode of the *|Z|tap* function:

- 1) Connect both sides of the connected load in parallel to the BLACK/RED monitor inputs.
- 2) While you are placed at the */Z| tap* function, press the  key and hold it down until a beep is heard and the function's LED starts blinking. You are now using the *secondary measurement* mode. In this mode, the measurement is performed using the value of the injected current and the voltage drop measured at the connected load.

Impedance measurement requires a minimum amount of current (at least 10 per cent of the selected tap's range) to be injected to the load. Non-linear loads, i.e. those that exhibit impedance changes with time because of large reactive components, cannot be accurately measured with this function.

Protecting your relay against test-related accidents

I lim and **T lim** functions automatically disconnect the output when the injected current or the ON time exceed a pre-established limit respectively.

You enter a current and/or time limit into Display #1 while placed in the appropriate function using the  and  buttons and then activate/deactivate the protection with the  button. These functions are primarily provided as a means to protect sensitive devices against accidental overheating.

The output will be cut off when the applied current exceeds the specified limit by a 10 per cent. While the Tlim protection applies to the time for which the output is ON, The Ilim protection works only with the current taps, not with the voltage taps Out1 or Out2.

Testing Instantaneous Overcurrent

Instantaneous elements trip usually before the PTE-100-C PRO's digital ammeter stabilizes itself on the Display #2, thus being impossible to know the real current value that has caused the relay to operate.

Furthermore, some instantaneous protections are set to such a high current value that it might damage the relay if sustained during the time that it usually takes to regulate with a reasonable accuracy.

If you meet any or both of these situations when testing instantaneous overcurrent relays, use the **I max**, **I lim** and **T lim** functions as follows:

- 1) Check first that the unit's output is deactivated and the variac is placed at its minimum "0" position.
- 2) Connect the current input from the relay to the current output tap that best accommodates the intended injection values. Flag the se-

lected output by means of the  button. Connect also now the relay's trip contact to the PTE-100-C PRO's black/green monitor inputs, so that the unit can detect the relay's operation and stop the test appropriately. Refer to the *Timer control* section above for details on how to setup the various timer start/stop modes.

- 3) Select the *I max* function and activate it by pressing  briefly. Its LED indicator will toggle from slow to fast blinking. In the *I max* mode, the PTE-100-C PRO's ammeter works *upwards only*, i.e., it shows the maximum injected current since the last time the output

was switched on, and it does it at a very high speed. You can now exit from *Func.* mode.

- 4) If you wish to avoid injecting an excessive amount of current accidentally while regulating your test current, use the *llim* function as described in *Protecting Your Relay*.
- 5) Do the same with the *Tlim* function entering the longest time for which you know it is safe to sustain the above specified current limit through your relay while you are regulating the test current. Do not forget to press **Enter/Print** to effectively activate this one and the *llim* protection (LED should toggle from slow to fast blinking). The specified time should be longer than the expected instantaneous operation time.
- 6) After you exit the *Func.* mode, the LEDs next to these three functions should be steadily lit. Otherwise, back up to *Func.* mode, navigate to the function and press **Enter/Print** to toggle its LED to fast blinking.
- 7) Do NOT press **RESET** now. Switch the output **ON** and try to reach the instantaneous setting for the current before the *Tlim* protection operates and the output is suspended.
- 8) Retry step 7) until you achieve the desired value for the instantaneous test setting in Display #2.
- 9) Press **RESET** to zero the timer out and to set the unit to suspend the output automatically upon relay's operation.
- 10) Press **ON** to start the test. The relay should operate before the time specified for *Tlim* elapses, and the injection will be automatically suspended. The resulting operation time and current will be shown by displays #1 and #2 respectively.
- 11) Check the relay's consistency by repeating steps 9) and 10) a couple of times and write the results down.
- 12) Repeat steps 7 thru 11 for each current value that you need to test.

Pre-setting a current value





If your test object's load is consistently linear, the **Preset** function provides a method to set a current value while the output switch is in the OFF position. When **Preset** is active, the unit calculates the current that would result from each position of the regulation knob at the 'flagged' current tap over the connected impedance. This *theoretical* value is shown in Display #2 though no current is actually being injected. This is possible by applying the formula

$$|I| = |V| / |Z|$$

where $|V|$ is the voltage that corresponds to the present position of the variac at the current tap where impedance $|Z|$ has been previously measured and stored (see *Measurement Functions* at the DESCRIPTION chapter).

This *calculated current* adjustment is useful when you need to test one relay over multiple settings in the same current tap. Beware, though, that the accuracy of this calculation is compromised when the connected load has a substantial amount of reactive (inductive or capacitive) components.

If you want to regulate the current before activating the output, do the following:

- 1) Check that the output is switched off and the variac is at its minimum ("0") position.
- 2) Connect the load to the current output that best accommodates the regulation range and flag it using the  button.
- 3) Go to the $|Z|$ tap function using the  and  buttons.
- 4) Without exiting the *Func.* mode, activate the unit's output and regulate it to a minimum 10 percent of the intended test current's upper limit. For example, if you are going to test between 5 and 20 A, regulate a little bit more than 2 A now.
- 5) Display #1 will be showing the measured impedance as you regulate the current. Press  now to save it into memory and switch the output off.

- 6) From now on, as long as you don't move the test load to a different tap, you can toggle the **Preset** function on and off to activate/suspend the *theoretical* current calculation in Display #2. To do this, just switch to *Func.* mode, navigate to the **Preset** function and press the  button. If two beeps are heard instead of one, repeat above steps 3) and 4) to properly measure and store the connected impedance value in memory and try again.

While **Preset** is active, compare the displayed current values at Display #2 before and after pressing  to activate the output. This will help you estimate the amount of error introduced by the nature of the load and the measurement and calculation method. The **Preset** function is provided as a means to help you save some regulation time. Refer to *Special Functions* at the DESCRIPTION section for details on the use of the **Preset** and **/Z/tap** functions.

CALIBRATING THE PTE-100-C PRO

One of the microprocessor-supported functions in the PTE-100-C PRO is the calibration and adjustment process. You don't need to open the unit or use any tools to readjust it. Just install the supplied FAA-CAL program on a Windows PC, connect it to the unit's serial port and follow the instructions to enter the readings from reference instruments into your PTE-100-C PRO.

Required equipment



To calibrate and adjust the readings of your PTE-100-C PRO you need the following equipment:

- RS-232 communications cable (supplied)
- FAA-CAL calibration utility (supplied) installed on a Windows PC
- Reference measurement instruments

The process consists basically of 1) comparing the readings in the PTE-100-C PRO's display to those measured by the reference equipment, 2) entering the reference value through the program if the one displayed on the PTE-100-C PRO is out of tolerance, and 3) producing a calibration report.

General Calibration Procedure

When you start FAA-CAL, it scans the available RS-232 ports in the PC for a connected PTE-100-C PRO. Therefore, first connect your unit to the PC using the supplied DB-9 cord, switch it on and activate its serial port by

pressing  and  until you hear an audible tone and a tiny rectangle is lit at the right edge of Display #1. Now you can launch the FAA-CAL program.

In a few seconds, a small window will show the connected unit's serial number. Click OK to accept and begin with the calibration process.

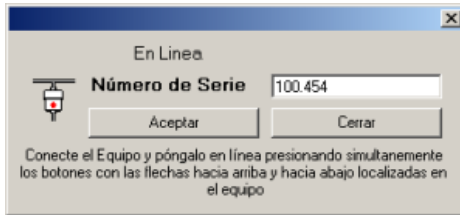

If the serial number of the connected PTE-100-C PRO is new in the FAA-CAL's equipment database, the program will create a new record for that unit and will acquire and save its adjustments into it automatically. This will allow you to back up to the factory settings in case you make mistakes and render the equipment unusable accidentally.

FAA-CAL displays a chronological list of all the adjustments done on one or more PTE-100-C PRO units to the date. To readjust the connected unit, click on "NEW" and follow the instructions provided with the program. If you wish to restore a previous set of adjustments to the connected equipment, highlight the desired line in the list and click on "Send to the Equipment".

SPECIFICATIONS

<u>Output Characteristics</u>	A.C. CURRENT	A.C. VOLTAGE «Out 1»	D.C. VOLTAGE «Out 2»	AUX D.C. VOLTAGE «Out 3»	AUX D.C. VOLTAGE «Out 4»
AVAILABLE RANGES	0-5 A, 0-25 A, 0-50 A, 0-100A	0-250 Vac	0-350 Vdc	0-250 Vdc	110 Vac
MAX CONTINUOUS CURRENT	1,5 A, 5 A, 10 A, 25 A	1 A	0.7 A	0.25 A	0.3 A
MAX CURRENT FOR 1 MIN.	5 A, 25 A, 50 A, 100 A 3 SECONDS: 250 A	4 A	2.8 A	0.25 A	0.3 A
MAX VOLTAGE ±10%	200 V, 40 V, 20 V, 10 V	250 Vac	350 Vdc	250 Vdc	110 Vac

<u>Special Functions</u>	PERCENTAGE CURRENT REGULATION	TIME LIMIT (SECONDS)	CURRENT LIMIT (A)	PRESETTABLE CURRENT
ADJUSTMENT RANGE	0.01 – 99.99	0.01-99999	0.1-100.0	0.1-100.0
RESOLUTION	0.01	0.01	0.1	0.1
DISPLAY #	1 & 2	1	1	1 & 2

<u>Meas. functions</u>	V a.c.	V d.c.	Frec. (Hz)	V a.c. TAP	ϕ (°)	POT. (VA)	IMPE D. (Ω)	TIME (sec.)
MIN	0.1	0.1	20.000	0.0001	0.0	00.01	000.01	0.001
MAX	250.0	250.0	2000.0	199.9	359.9	99.99	999.99	99999
ACCURACY (10 to 100% of range)	$\pm 1\%$ R ± 1 dig	$\pm 1\%$ R ± 1 dig	± 0.003 Hz ± 1 dig	$\pm 1\%$ R ± 1 dig	$\pm 2^\circ$ ± 2 dig	$\pm 2\%$ R ± 1 dig	$\pm 2\%$ R ± 1 dig	$\pm 0.01\%$ of reading ± 1 dig
RESOLUTION	0.1 V	0.1 V	0.01 Hz	0.01 V	0.1°	0.01 VA	0.001	0.001

Voltage Supply

230V $\pm 10\%$ (115V $\pm 10\%$ Upon request) 50 Hz - 60 Hz

Physical Dimensions

Height: 200 mm. / width: 300 mm. / depth: 200 mm. Weight: 13.5 Kg.

GENERAL DIAGRAM

PTE-100-C
GENERAL DIAGRAM

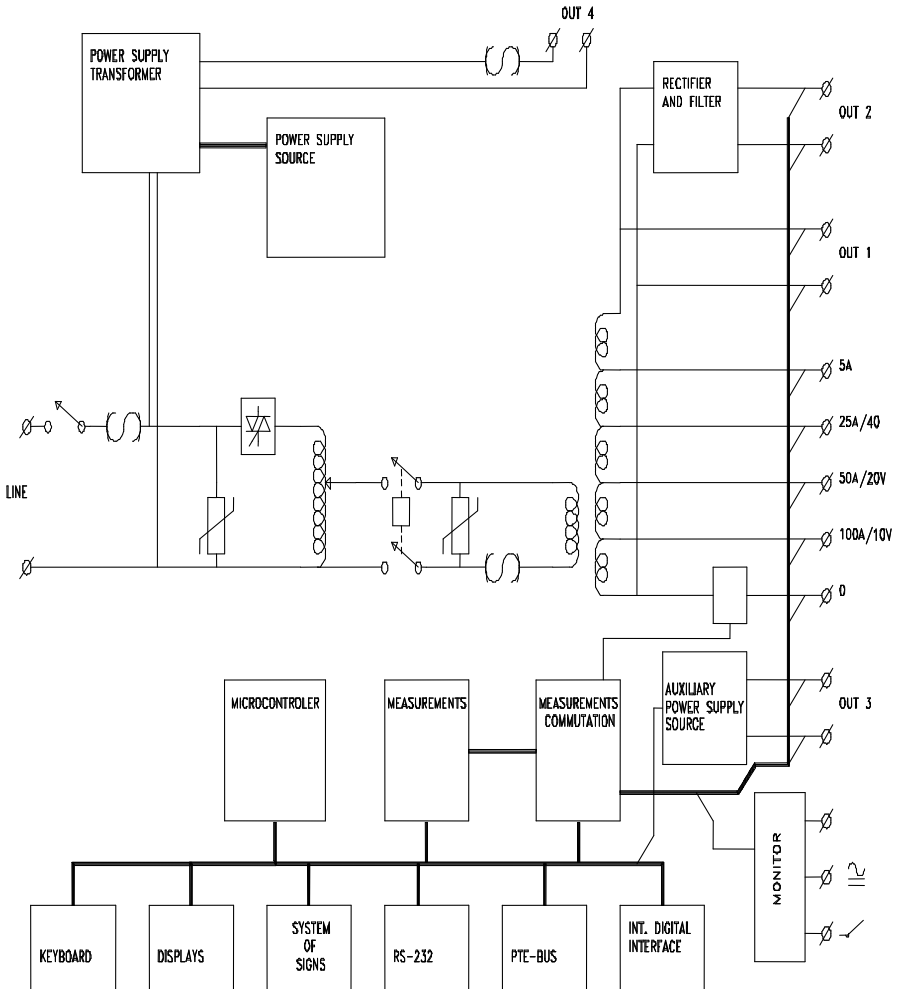

FIGURE 1

FRONT PANEL



THE PTE-FCN VOLTAGE MODULE

The PTE-100-C PRO includes the PTE-FCN module, an electronically controlled independent voltage channel that allows you to test overcurrent, distance, synchronism, frequency and many other types of relays easily.

The optional windows-based PTE-OCT program can also make testing and reporting much easier, by assisting you from a standard PC throughout the whole process. For more information on this and other available options for your PTE-100-C PRO, visit www.smcint.com or call us at +34 918498980.

DESCRIPTION

Powering the PTE-FCN

The PTE-FCN module can only be powered from the PTE-100-C's built-in 110VAC auxiliary output, "Out 4". This is due to the fact that we use switching amplifiers where the output is NOT isolated from the power input.



To power the PTE-FCN module, use the included bipolar cord to connect the module exclusively to the 110VAC auxiliary output "Out 4" built into the PTE-100-C PRO. Using any other AC supply can permanently damage the unit and will invalidate the warranty.

Power output

Output from the module is located at the black/red 4-mm, 25A rated female connectors at the lower left corner. Remember, the output is NOT isolated from the input. Always ground the unit using the yellow EARTH connector.



Adjusted voltage Level, Frequency and Phase Angle at the PTE-FCN's output are shown at the built-in LCD display.

BUTTONS AND LEDS

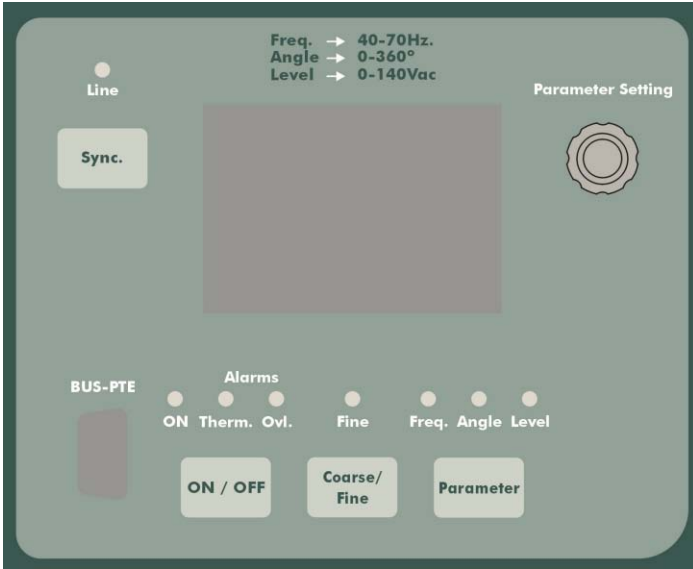

The PTE-FCN’s output is regulated by means of a single rotary knob and four control buttons, used as follows:



Press this button to switch the output ON and OFF. The associated red LED will indicate the present output state.



Press this button to toggle the module’s phase reference from “Line” (i.e. the PTE-100-C’s 50 or 60-Hz AC supply line) to its internal wave generator, whose frequency you can change as described next.

When Line is selected as the synch reference, the LCD display shows the phase angle between this voltage and the current being injected by the main PTE-100-C unit.

When Line is deselected, the LCD display shows the adjustable output voltage’s frequency, which is generated by the PTE-FCN module and, therefore, is no longer referenced to the main unit’s current or voltage outputs.

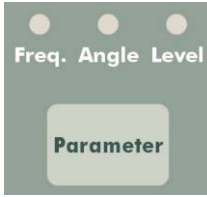

The rotary knob adjusts the parameter that you have previously selected here. If *Synch* is set to “Line”, the frequency is fixed so you can only regulate *Phase Angle* and *Level*. If *Synch* is not “Line”, the internal frequency generator is used as reference, so you can only regulate *Frequency* and *Level*.



Select the rotary knob’s adjustment resolution here, according to these Fine and Coarse step values:

Parameter	Fine	Coarse
Level	0.1 V	10 V
Frequency	0.1 Hz	1 Hz
Phase	0.1 °	10 °



Alarm indicators

The PTE-FCN module is protected against overheating and overcurrent by means of these automatic LED-signalled *Therm* and *Ovl.* alarms respectively.

The thermal protection operates when temperature builds up inside the module excessively, and is automatically cleared when it cools down.

The overload protection operates when the module cannot maintain the adjusted voltage across the connected load, or when the AC supply drops more than 10%.

In both cases, the module’s output is suspended and cannot be resumed until the faulty condition is cleared.

INTERNAL PROTECTIONS

The module’s output will also be suspended if the supply level falls below a minimum level. At even lower supply levels the module would automatically reset itself.

POWER-UP STATE

Upon connection to the supply source, the unit will have these settings:

- Output: OFF.
- Voltage Level: 0.
- Frequency: 50.0 Hz.
- Phase Angle: 0.0 °.
- Synchronizing reference: Line (same one as PTE-100-C's).
- Adjustment resolution: Coarse.

Working with the PTE-FCN module

1. **Power Supply:** Use the supplied bipolar cord to take 110VAC from the PTE-100-C PRO's "Out 4" auxiliary output into the PTE-FCN's power input.
2. **Ground:** Use the supplied yellow/green cord to connect the yellow GROUND tap in the PTE-FCN module to the main unit's chassis.
3. **BUS-PTE:** Link the main unit and the PTE-FCN module by connecting the supplied communications cable to their respective BUS-PTE connectors. This will provide the necessary phase angle reference to the PTE-FCN module.
4. Turn the main unit on; the PTE-FCN module will turn itself on automatically.

Adjusting the LCD screen's contrast

Press the adjustment knob for 3 seconds to enter the LCD contrast adjustment mode; then, rotate the knob to adapt the contrast to the surrounding light conditions. To return to the normal adjustment mode, press the knob again for 3 seconds and release it. This display will automatically compensate the effect of small temperature variations in the contrast before you need to readjust it again. The PTE-100-C PRO 'remembers' the LCD's contrast adjustment from one work session to the next.

PTE-FCN TECHNICAL CHARACTERISTICS

Power supply	110 Vac \pm 10 %
Output voltage regulation	0.0 – 140.0 Vac
Voltage adjustment resolution / accuracy	0.1 Vac / \pm 0.1 V
Output frequency range	40.0 – 70.0 Hz
Frequency adjustment resolution / accuracy	0.1 Hz / \pm 0.1 Hz
Phase angle adjustment range	0 – 359.9 °
Phase angle adjustment resolution / accuracy	0.1° / \pm 0.1°
Output Power (70 – 140 Vac)*	30 VA
Max Current (0 – 70 Vac)*	0.42 Aac
Output mode	Ground-isolated
Protections	Thermal and overload

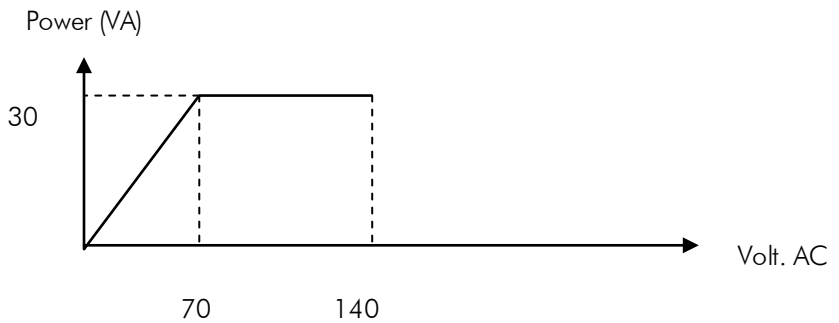

* Output power / output voltage characteristic curve.

PTE-FCN FRONT PANEL

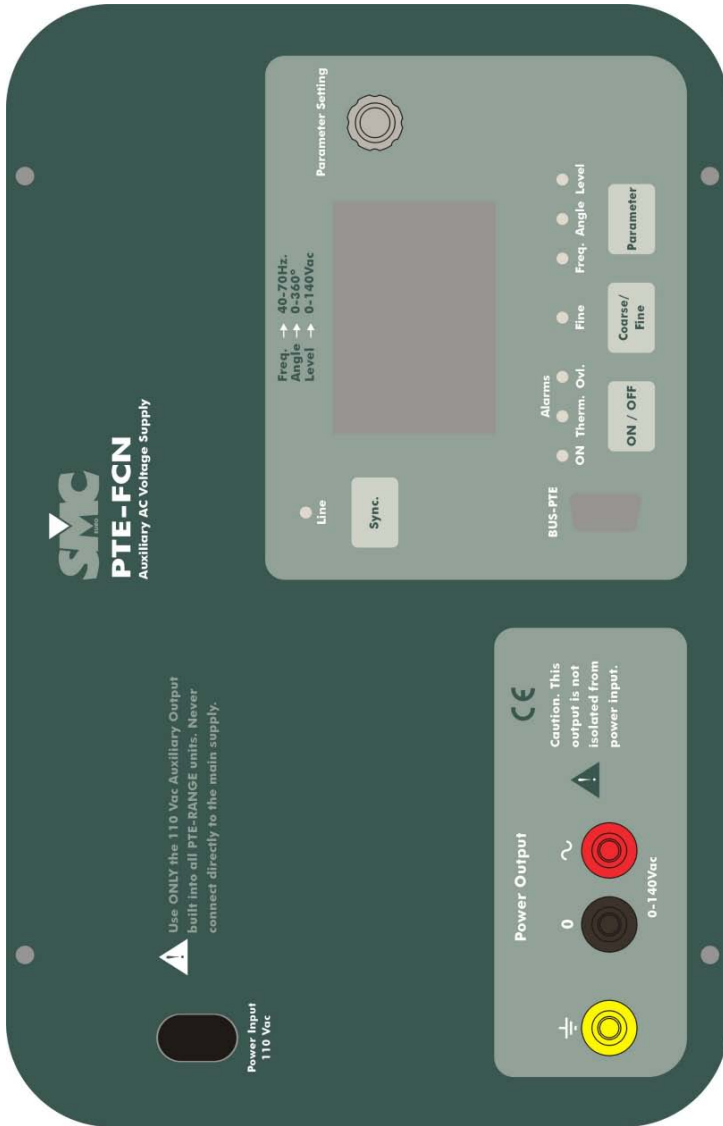

AFTER SALES SUPPORT

WARRANTY

This is an expression of trust that our products obtain. based on the reliability and functionality standards that our customers expect.

The warranty covers the free replacement or repair of defective components for one year in the terms specified in the supplied warranty statement and registration card.

Damages resulting from improper handling of the product, use outside the scope and limits of the product's specifications, negligence, installation not in accordance with the standards or warnings listed in the Instructions Manual and servicing or manipulation by unauthorized persons are not covered by the warranty.

CUSTOMER SUPPORT

EUROSMC guarantees the supply of materials and components for its products up to 3 years after discontinuation. This support is extendable to 5 years for technical service.

OTHER EUROSMC PRODUCTS

Portable Relay Test Equipment and Software

Primary injection units up to 20.000 A

Digital handheld chronometer.

Digital handheld phase angle meter

Digital Portable microhmeter up to 600 A Test current.

Test systems for automatic miniature circuit breakers.

Voltage and current regulation equipment.

Step & Touch Voltage measurement equipment

Power transformer maintenance equipment

Rotary machine insulation analysis equipment

IMPORTANT

