

peerless-AV[®]

DS-LEDFLAAF-3X3

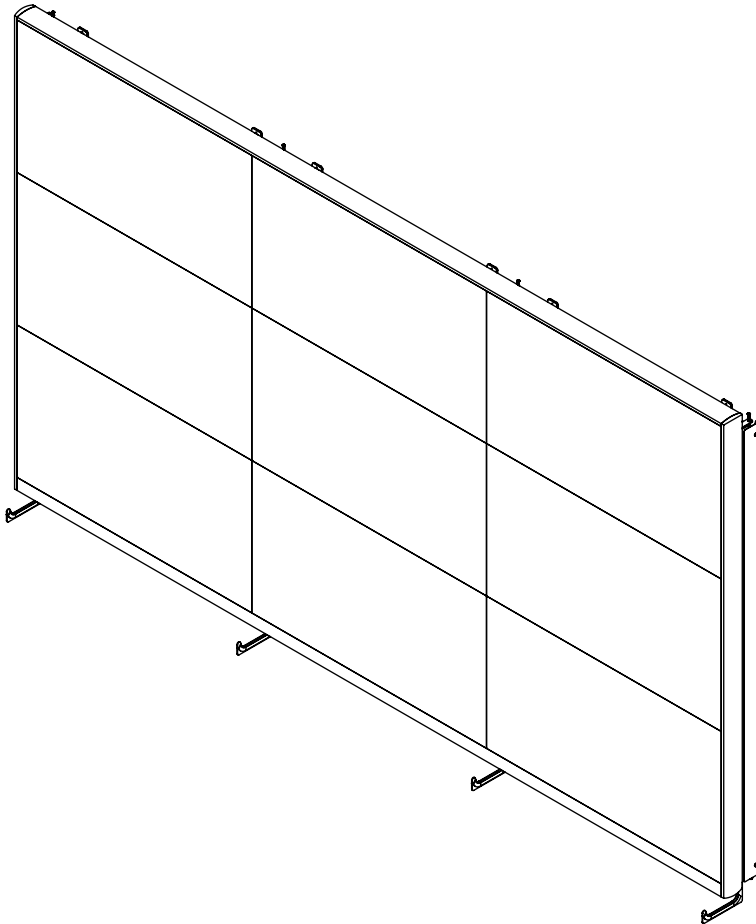

▲ WARNING

ENG - This product is designed to be installed on plywood walls. Hardware is included for plywood installation. This product is designed to be installed on flat, unobstructed, vertical walls. Do not install on curved or angled walls. Before installing make sure the supporting surface will support the combined load of the equipment and hardware. Screws must be tightly secured. Do not overtighten screws or damage can occur and product may fail. Never exceed the Maximum Load Capacity. Always use an assistant or mechanical lifting equipment to safely lift and position equipment. This product is intended for indoor use only. Use of this product outdoors could lead to product failure or personal injury. Be careful not to pinch fingers when operating the mount. For support please call customer care at 1-800-865-2112.

ENG Symbols



ENG WARNING



ENG Skip to step.



ENG Wear anti-static gloves.

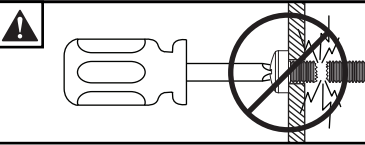

ENG Do not overtighten screws.



ENG To properly tighten screws: Tighten until screw head makes contact, then tighten another 1/2 turn. Do not overtighten screws.

1

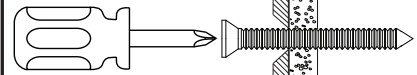

2

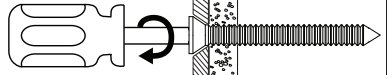

3

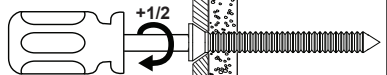

4



ENG Tools Needed for Assembly.

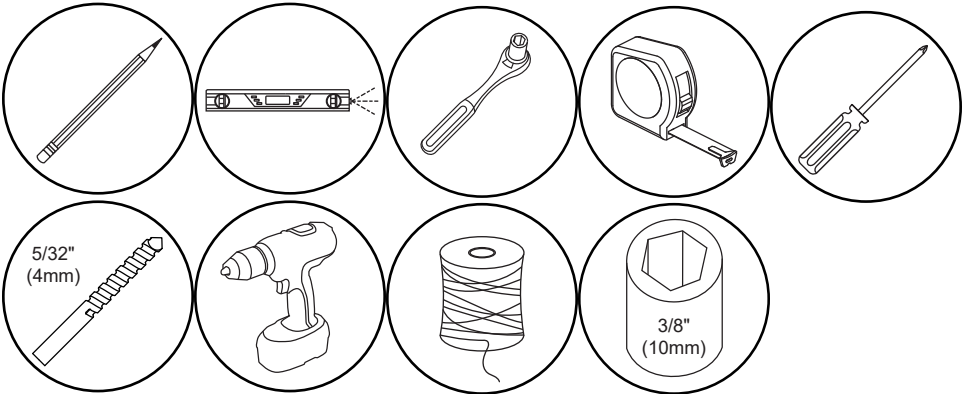

ENG Parts (Before beginning, make sure you have all parts shown below).
Refer to parts list included with your model.

Parts List

Description	Qty	Part #
A connector plate	19	096-1714
B horizontal spacer	2	096-1718
C vertical spacer	3	096-1715
D side trim	2	096-1716
E harness holder	4	096-1731
F upper left wall plate assembly	1	096-1719
G upper right wall plate assembly	1	096-1720
H lower left wall plate assembly	1	096-1721
I lower right wall plate assembly	1	096-1722
J vertical column double	2	096-1772
K vertical column single	2	096-1771
L M5 x 8mm	38	520-1144
M M5 x 6mm	4	520-9504
N wood screw	18	521-1688
O M4 x 75mm	36	521-1060
P 4mm allen wrench	1	560-9646
Q 3mm t-handle allen wrench	1	561-0119

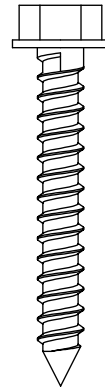
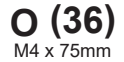
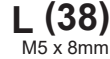
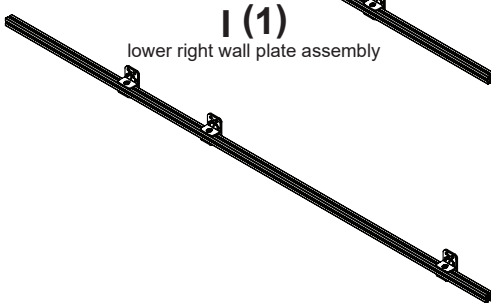
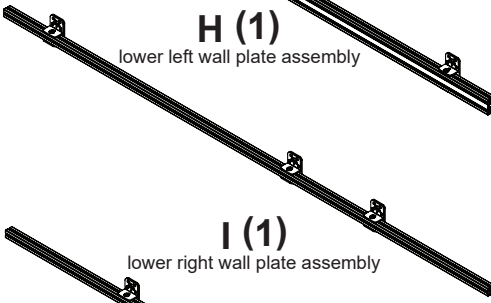
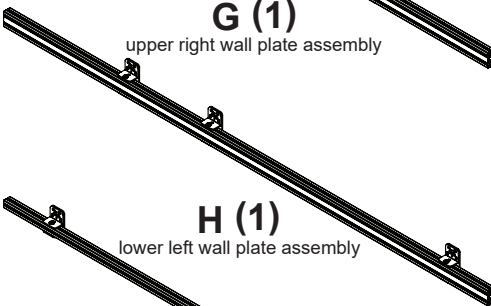
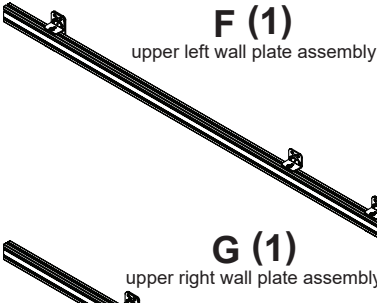
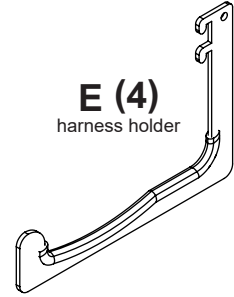
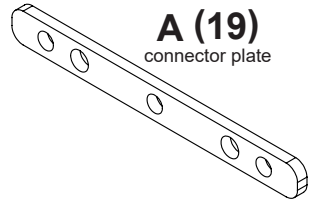

B (2)
horizontal spacer



C (3)
vertical spacer

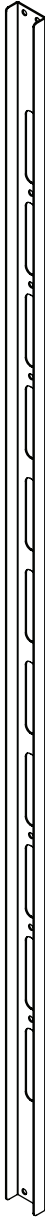

D (2)
side trim



J (2)
vertical column
double



K (2)
vertical column
single

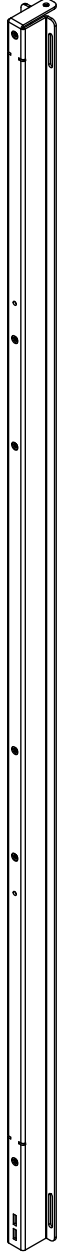

1

ENG Dimensions are for reference only. Use spacers provided.

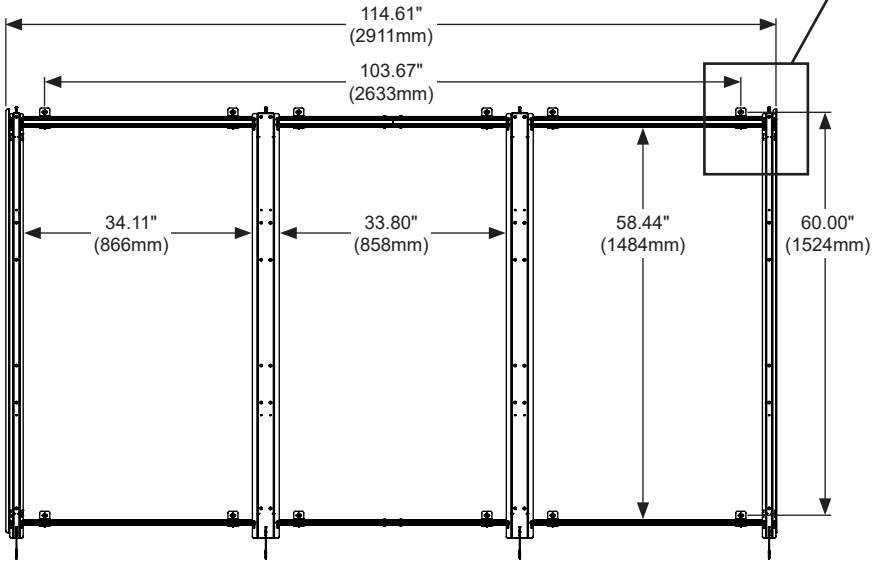
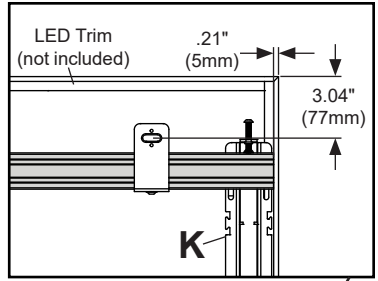

2-1

ENG Use extrusion connectors to connect top horizontal wall plate assemblies.

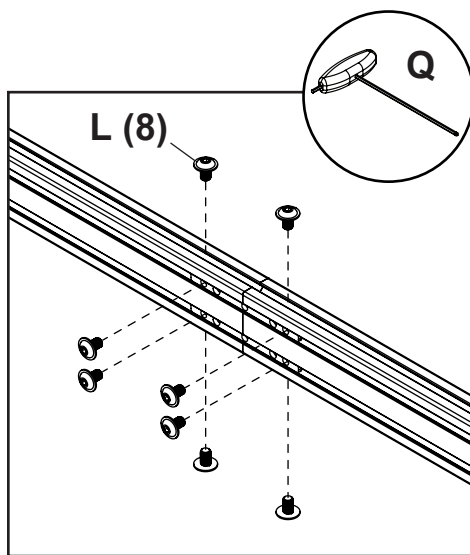
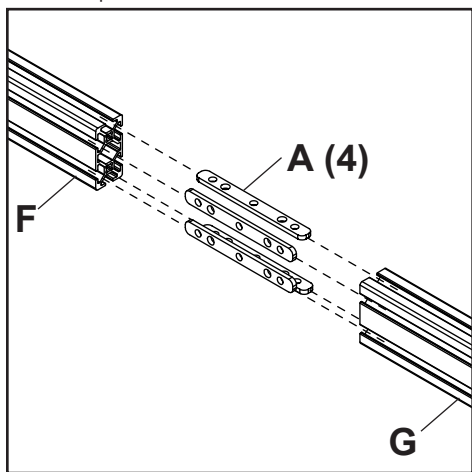

2-2

ENG Use extrusion connectors to connect bottom wall plate assemblies.

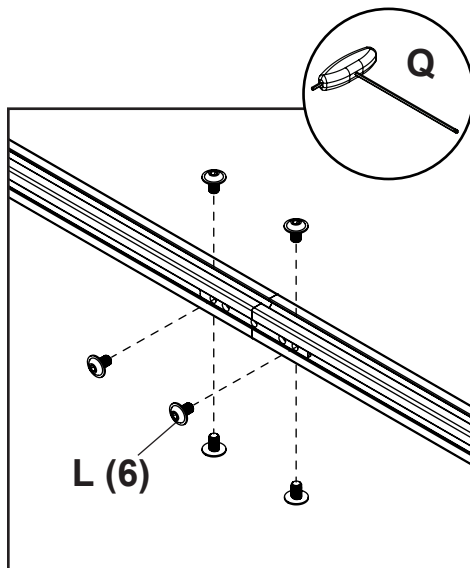
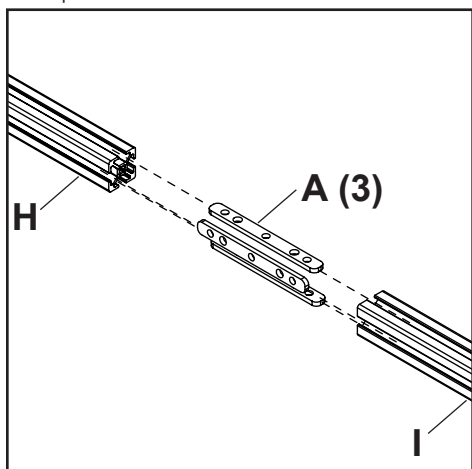

3

▲ WARNING

ENG - When installing Peerless wall mounts on a wood stud wall covered with plywood, verify that the wood studs are a minimum of 2" x 4" nominal size and plywood is a minimum Grade BC, 1/2" (13 mm) thick. Plywood may be covered by gypsum board (drywall) up to 5/8" thick.

3-1

ENG When installing more than one display to a wood stud wall reinforced with plywood (minimum Grade BC, 1/2" thick) that may be covered in gypsum board (drywall) up to 5/8" thick, the mounting surface must be plumb (+/- .20") across the height of the video wall and straight (+/- .20") across the width of the video wall.

3-2

ENG Use a laser level to keep mounting holes level.

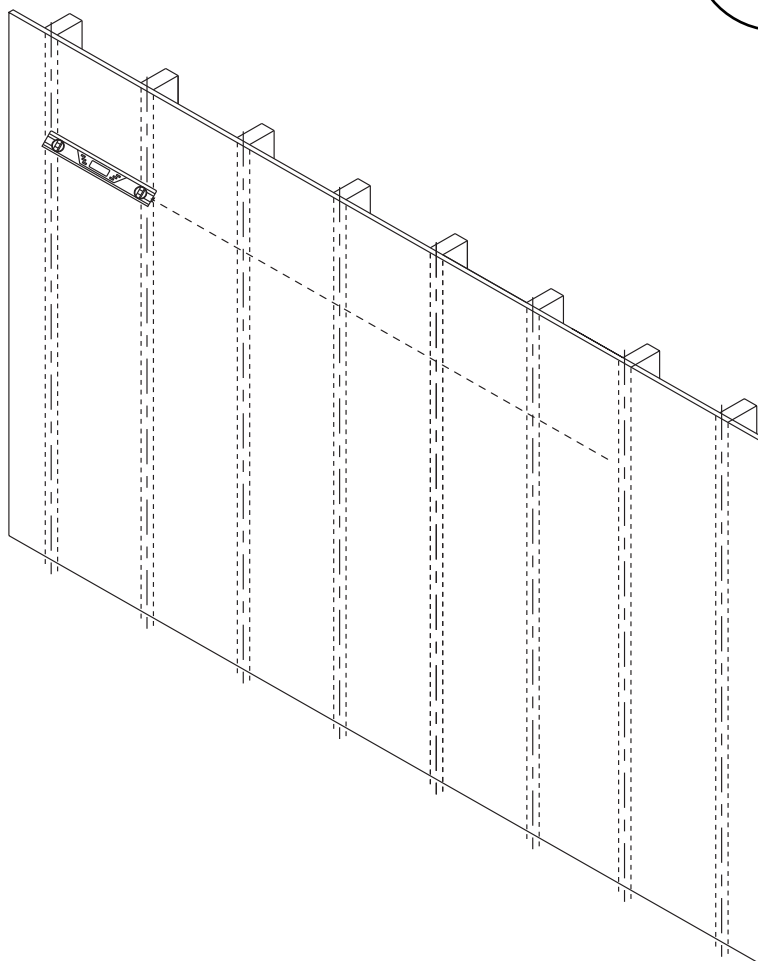
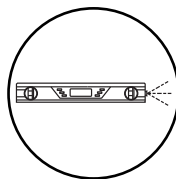

3-3

ENG Level wall plates and mark mounting holes on plywood (must be minimum Grade BC, 1/2" (13mm) thick.)

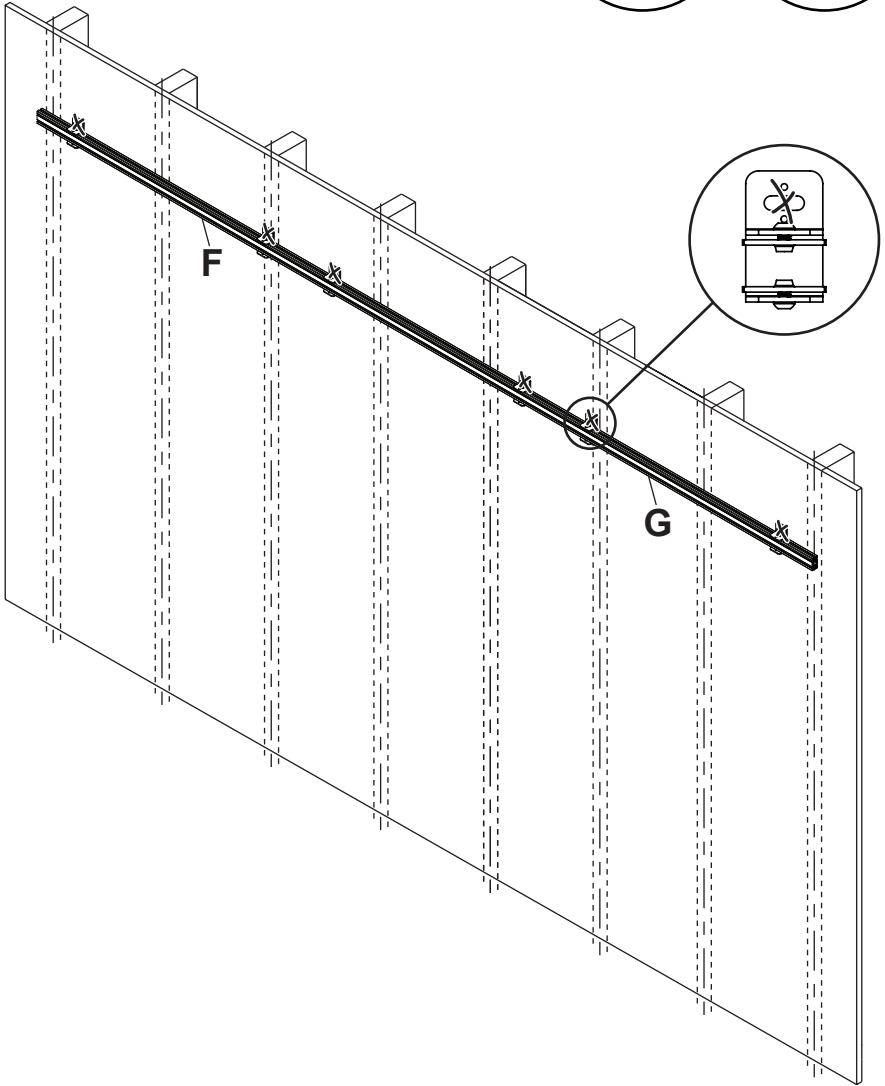
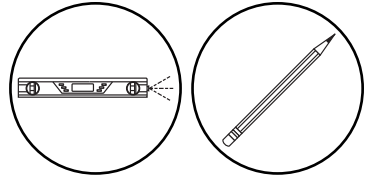

3-4

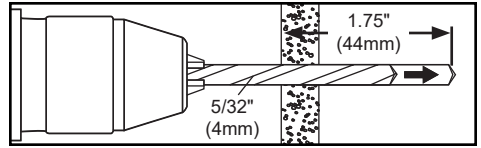
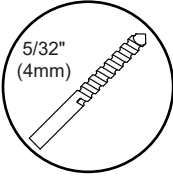

ENG Drill mounting holes into supporting surface (1.75" (44mm) minimum depth required).

3-5

ENG Level wall plates. Install using wood screws provided.

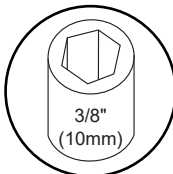
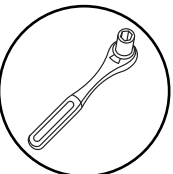
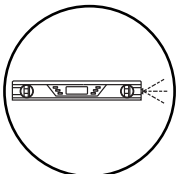
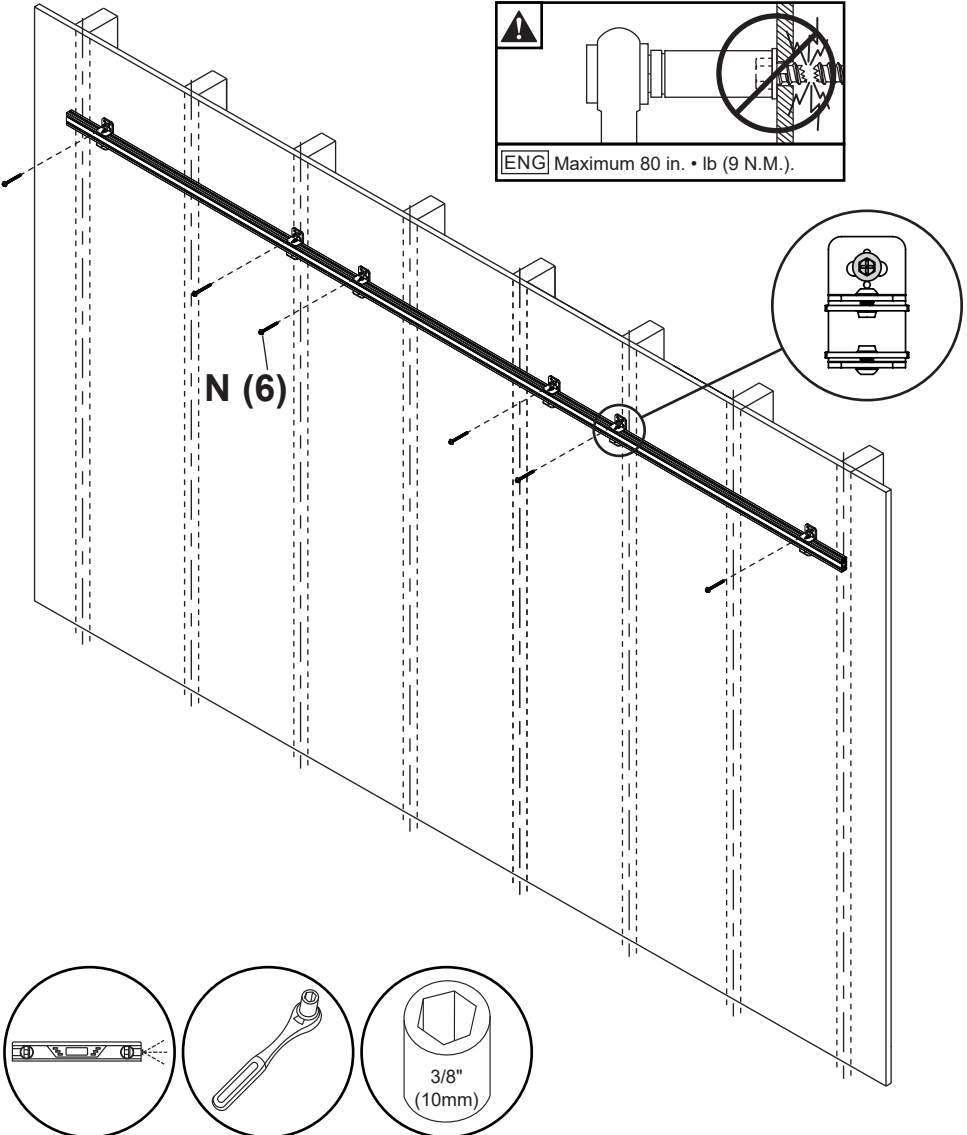
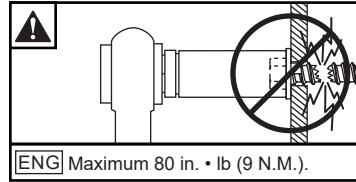

3-6

ENG Secure vertical spacers to the wall flush with the horizontal extrusion.

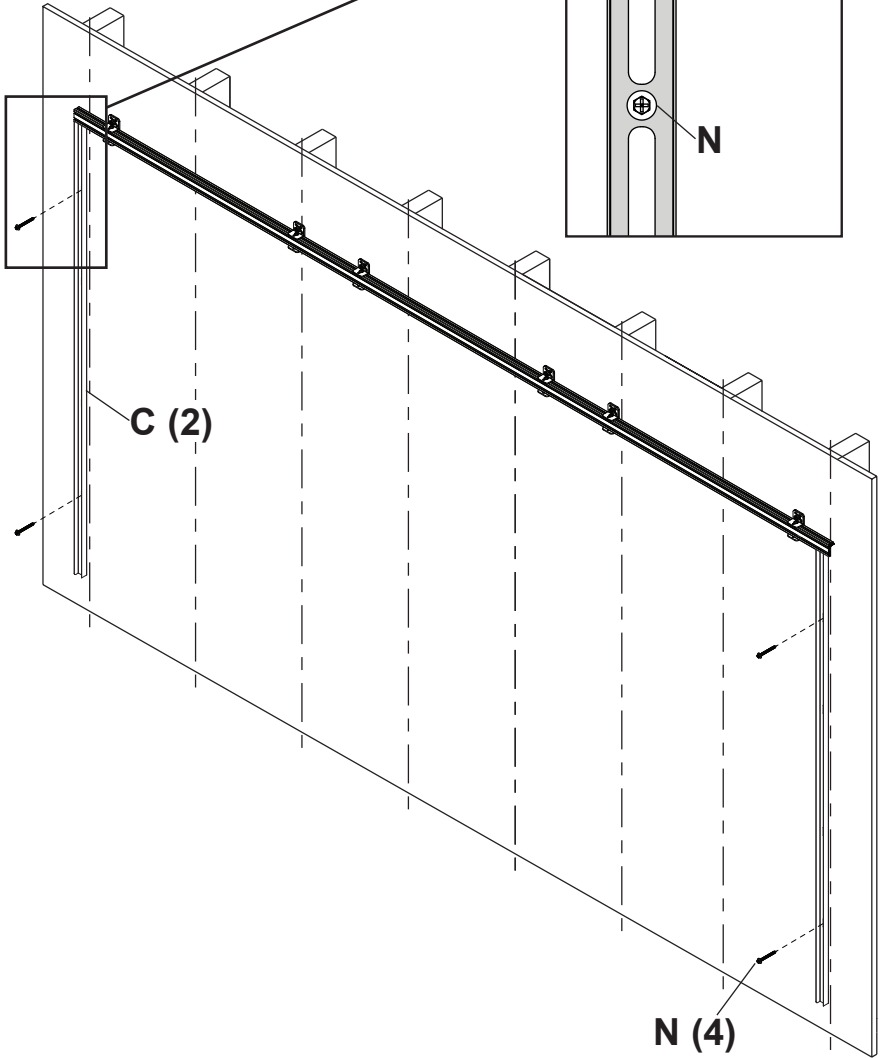
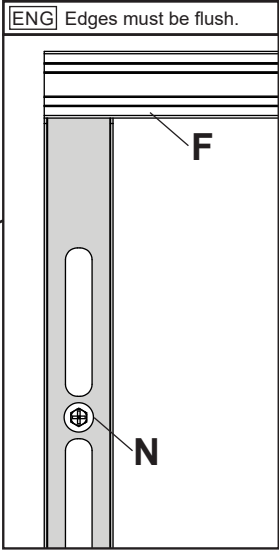
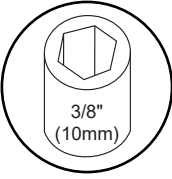

3-7

ENG Use third vertical spacer to align bottom horizontal extrusion flush with vertical spacer, then mark mounting holes on plywood (must be minimum Grade BC, 1/2" (13mm) thick.)

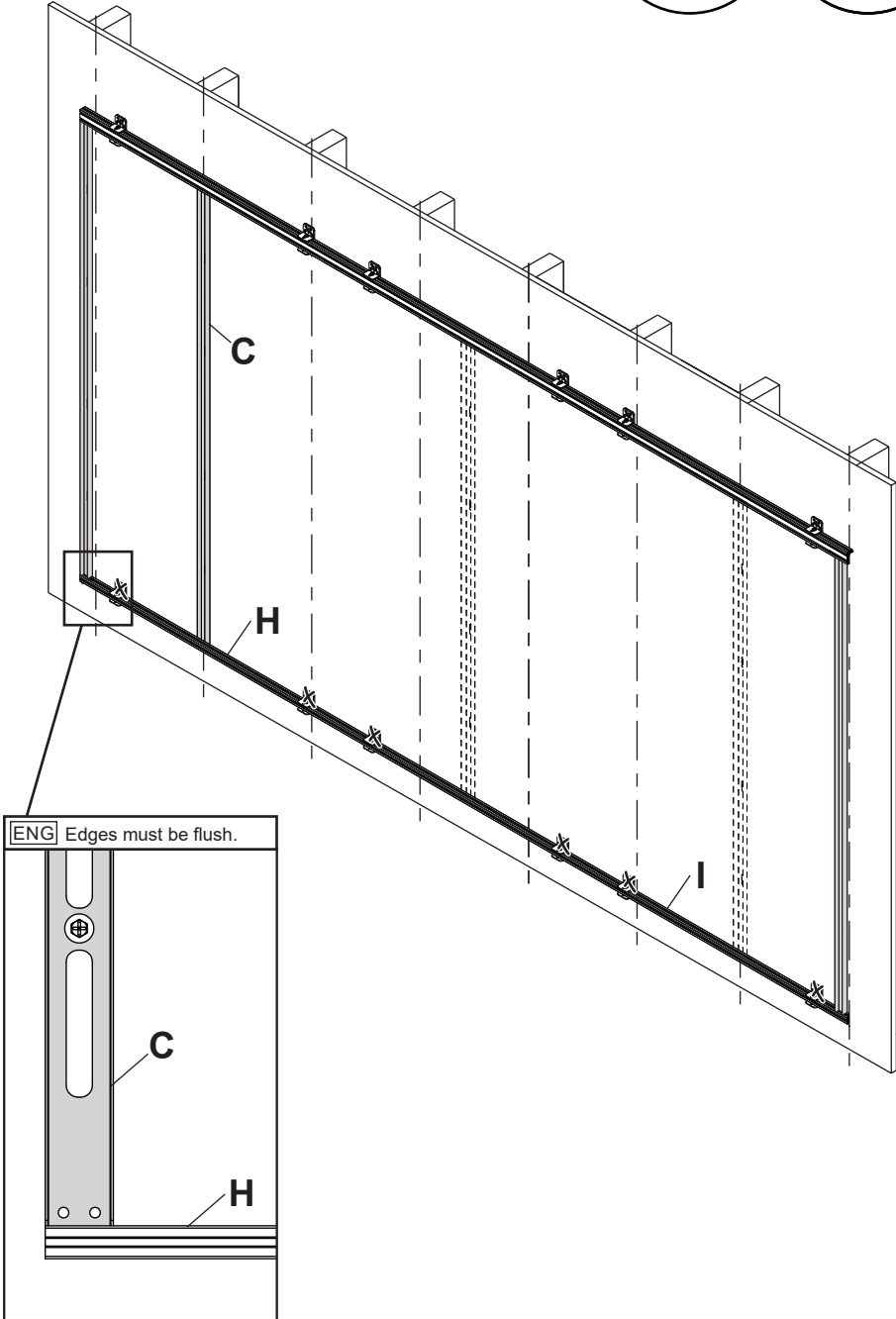
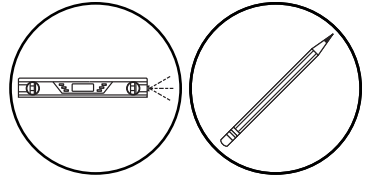

3-8

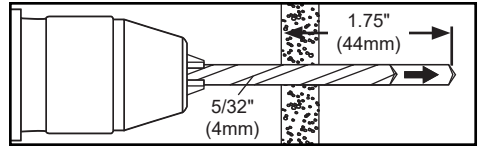
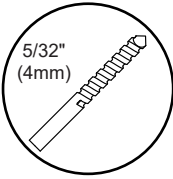

ENG Drill mounting holes into supporting surface (1.75" (44mm) minimum depth required).

3-9

ENG Level wallplates. Install using wood screws provided.

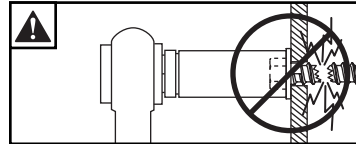

ENG Maximum 80 in. • lb (9 N.M.).

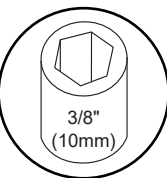
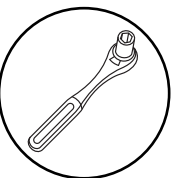
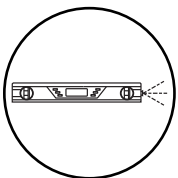
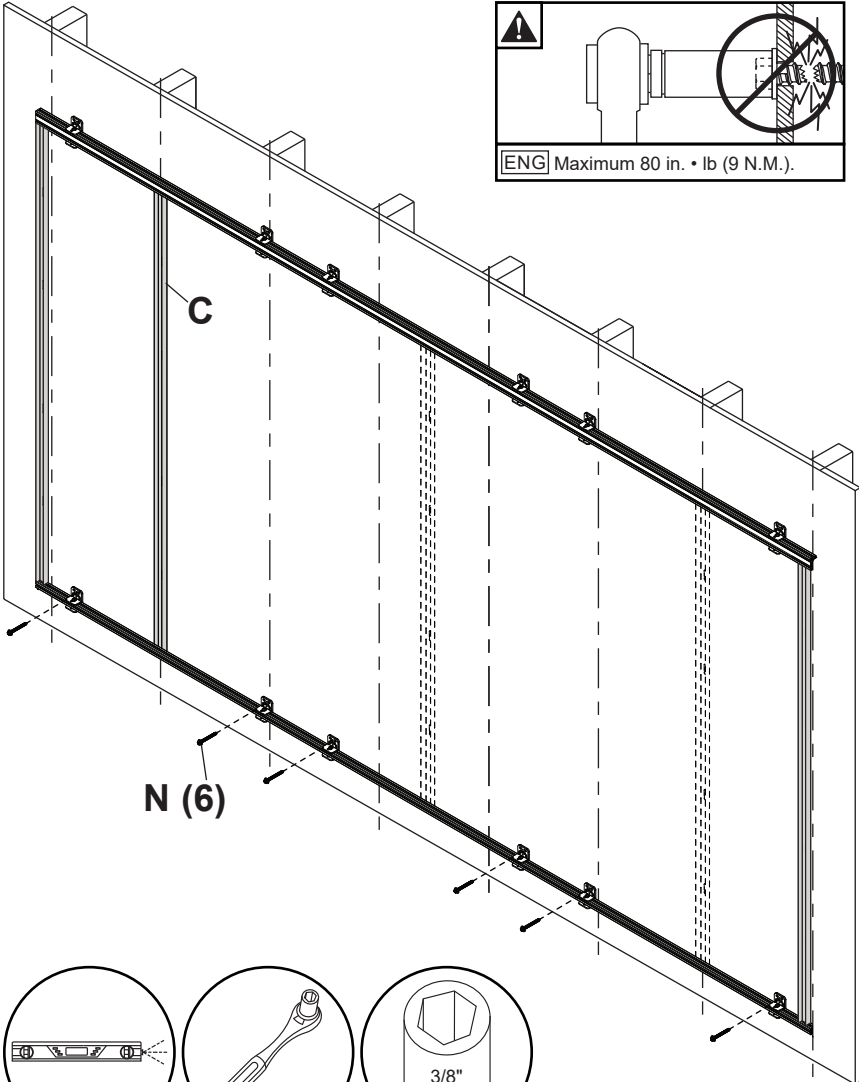

4

ENG Remove vertical spacers (C).

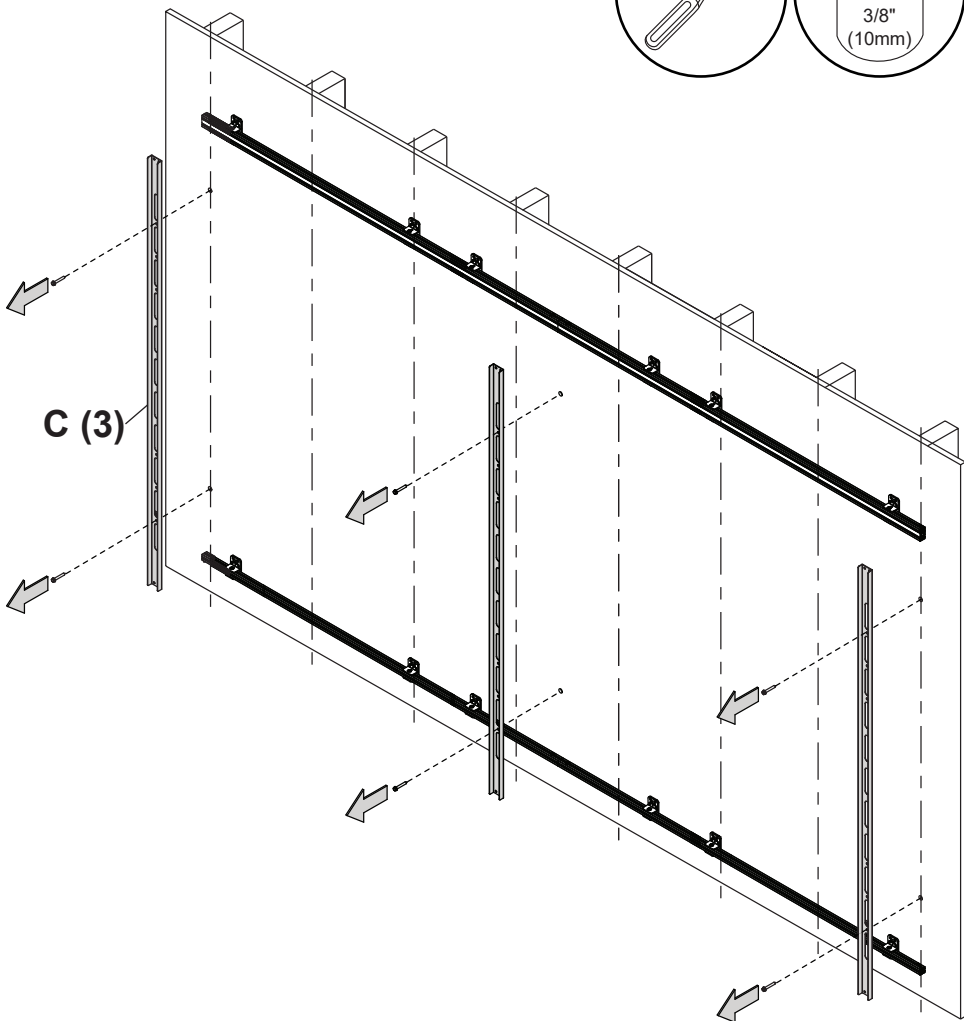
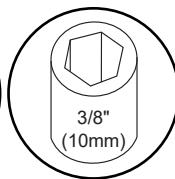
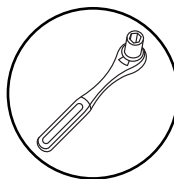

5-1

ENG Insert nuts for vertical assemblies using end of allen wrench.

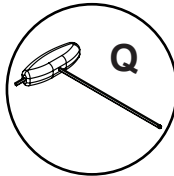
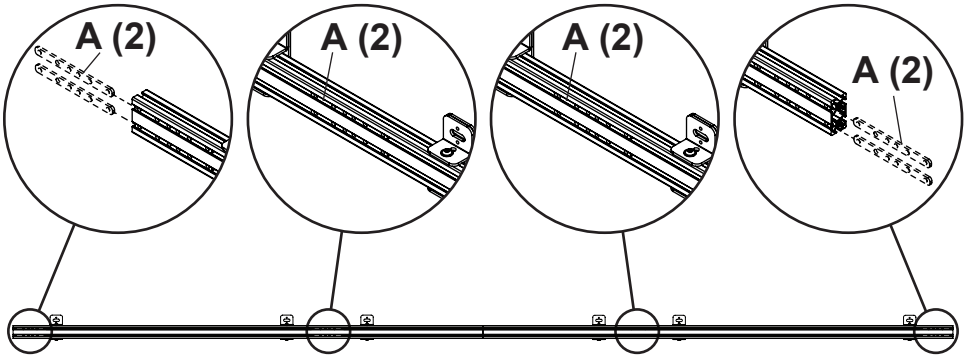

5-2

ENG Attach vertical assemblies. Do not tighten hardware.

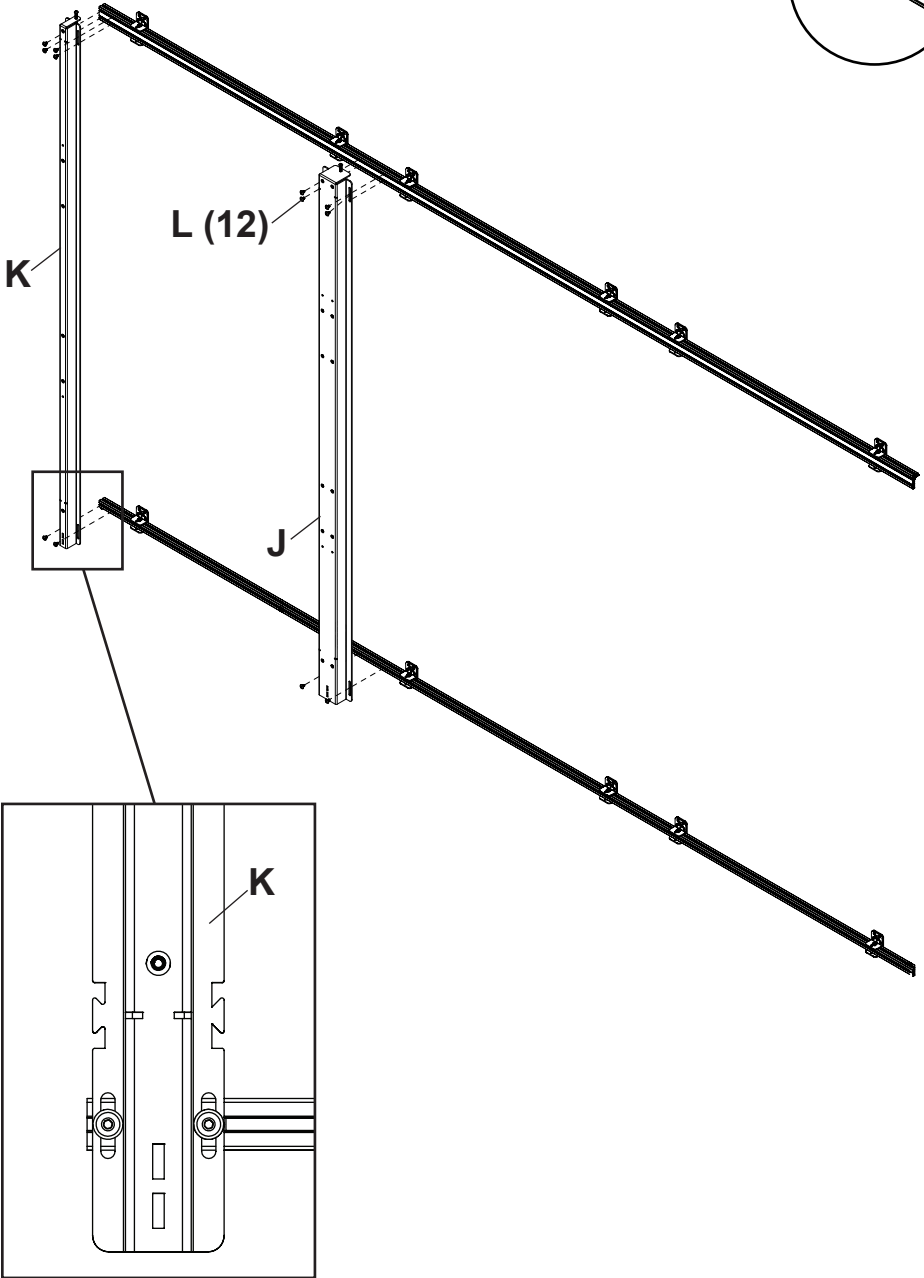
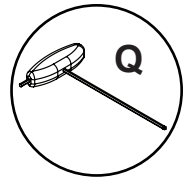

5-3

ENG Space vertical assemblies then tighten hardware.

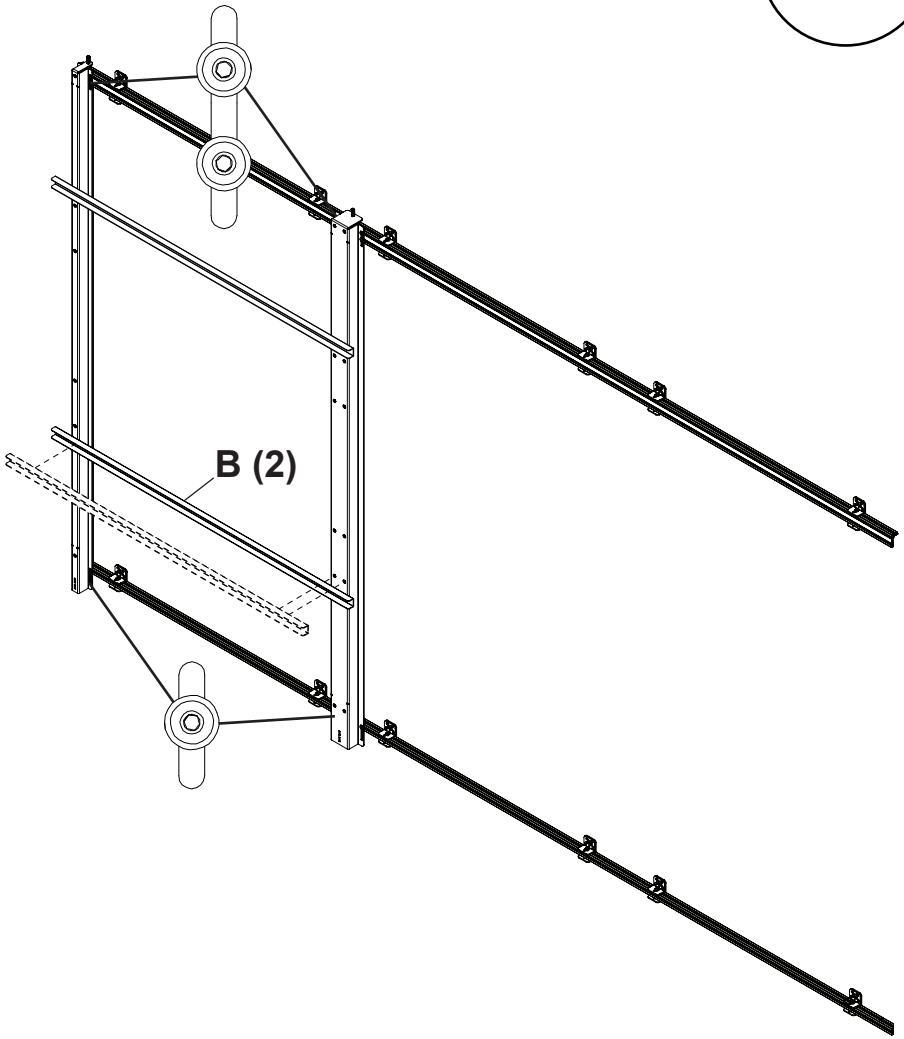
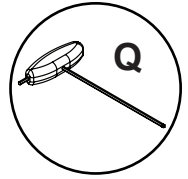

5-4

ENG Insert vertical assemblies onto extrusions.
Do not tighten hardware.

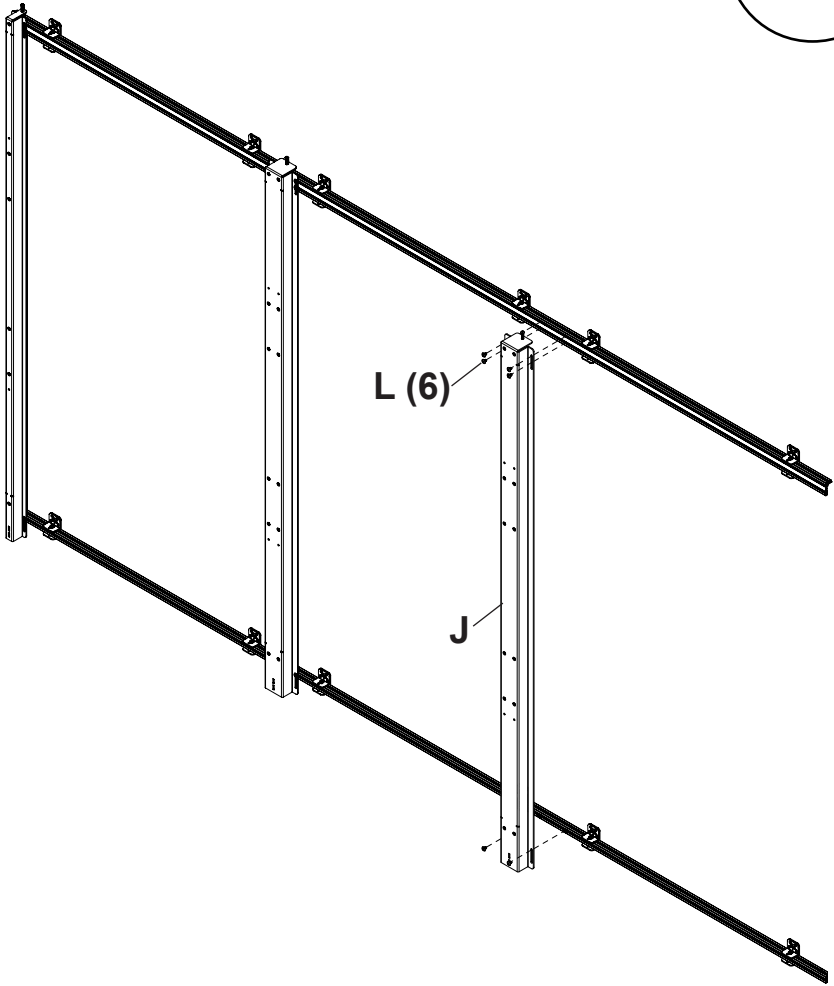
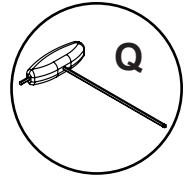

5-5

ENG Space vertical assemblies then tighten hardware.

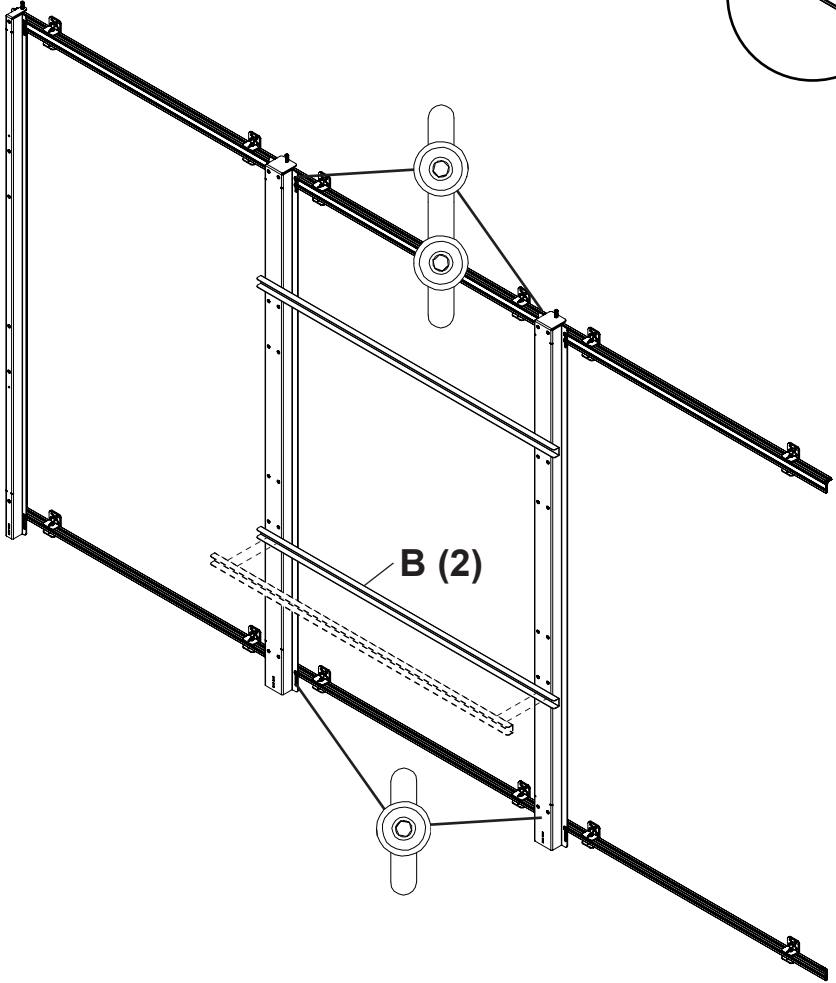
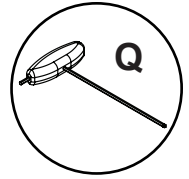

5-6

ENG Insert vertical assemblies onto extrusions.
Do not tighten hardware.

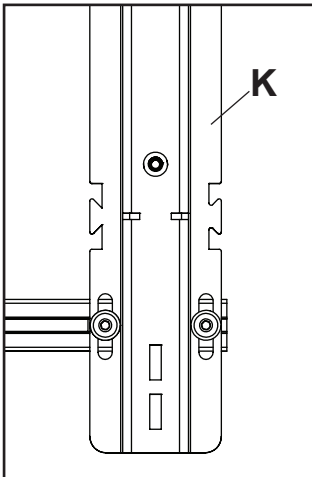
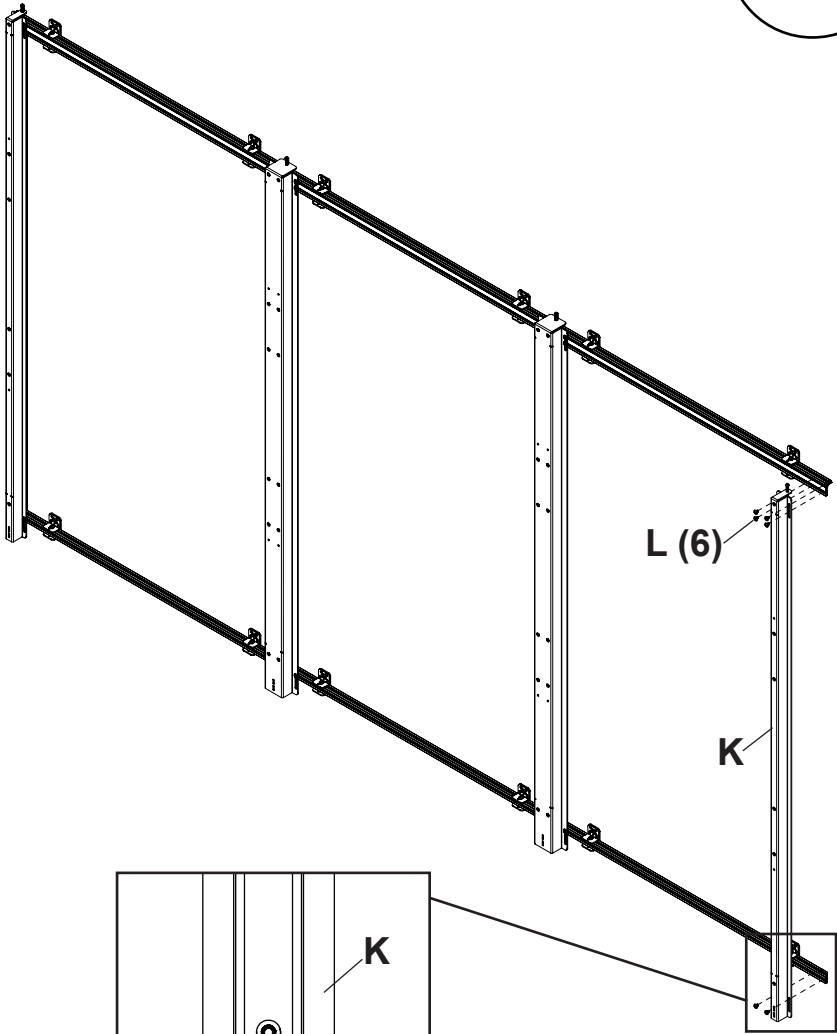
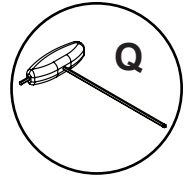

5-7

ENG Space vertical assemblies then tighten hardware.

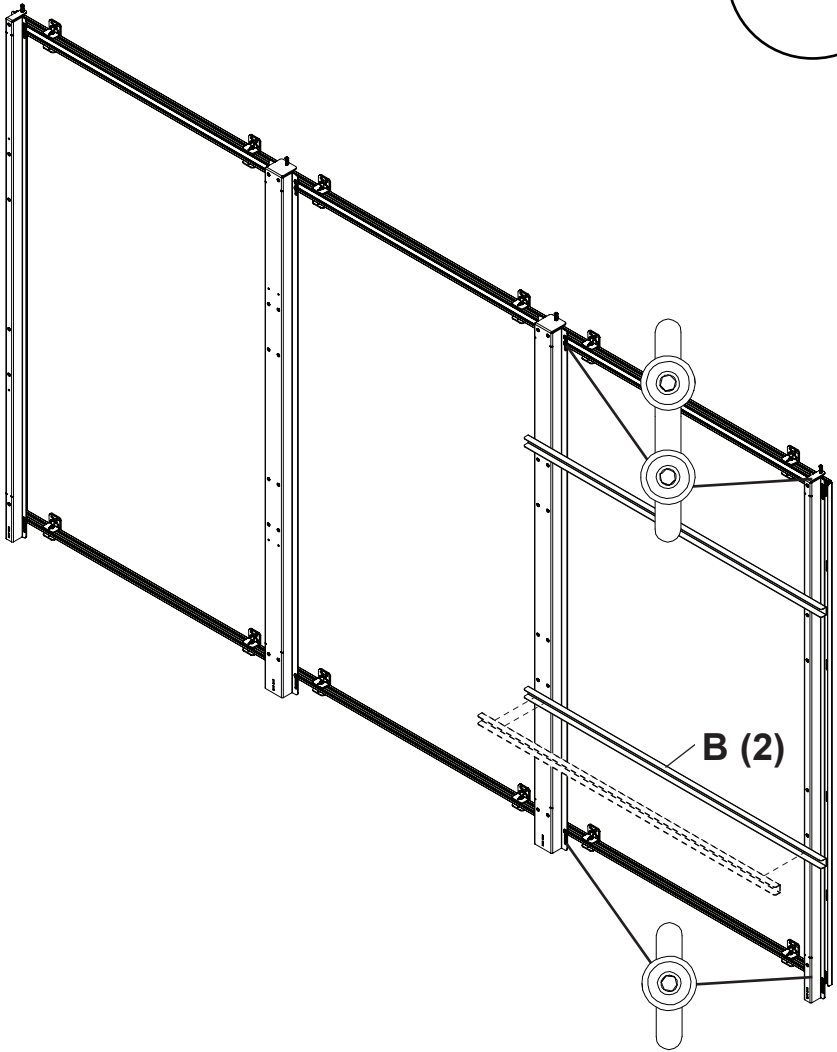
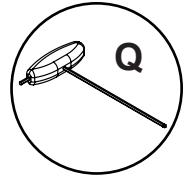

6-1

ENG Tie a string around the butterfly cut on outer columns in order to level the depth of each vertical column.

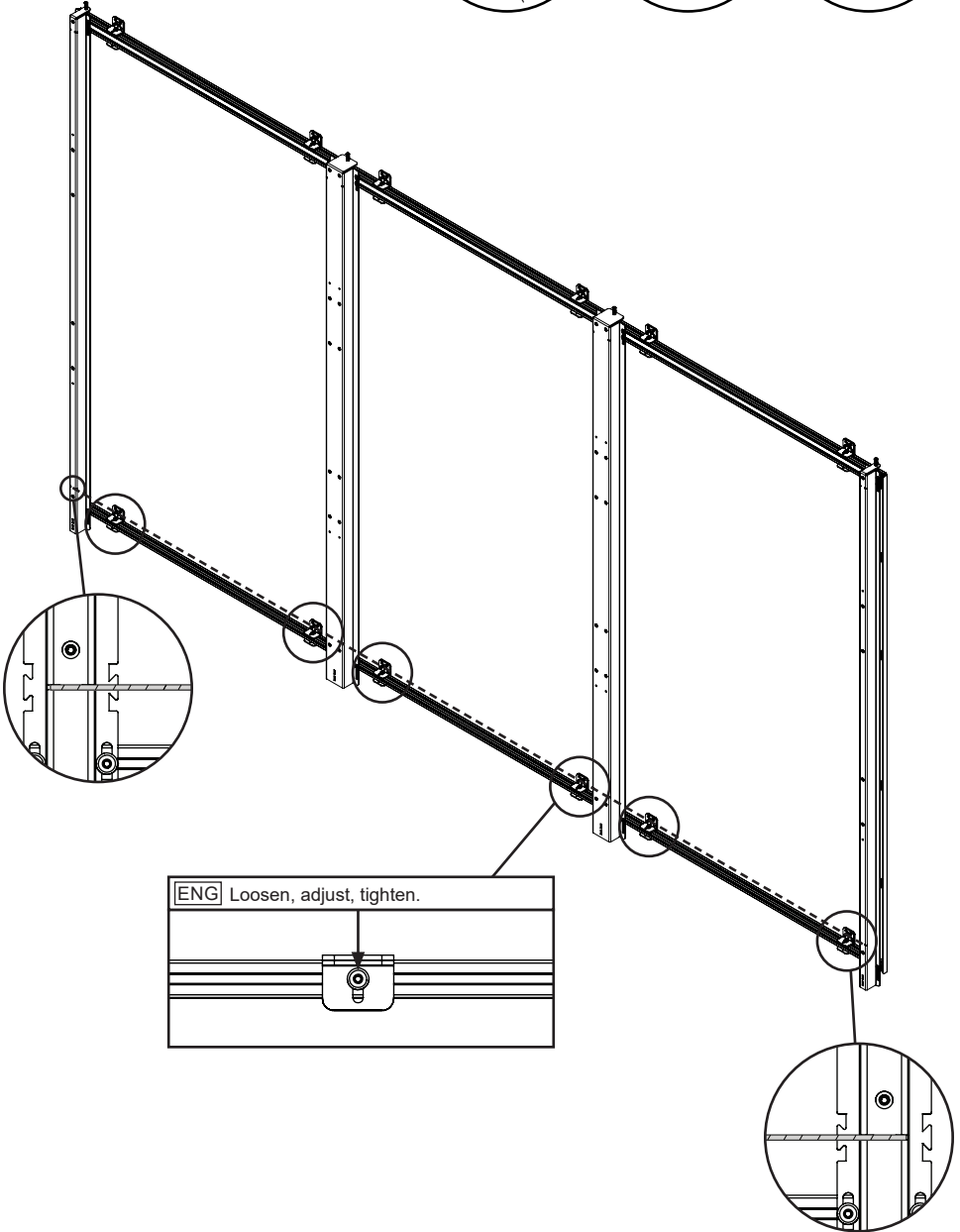
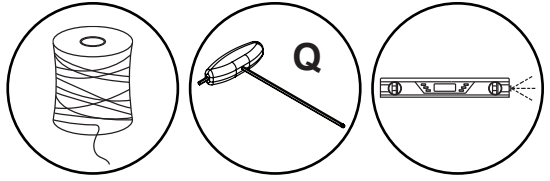

6-2

ENG Tie a string around the butterfly cut on outer columns in order to level the depth of each vertical column.

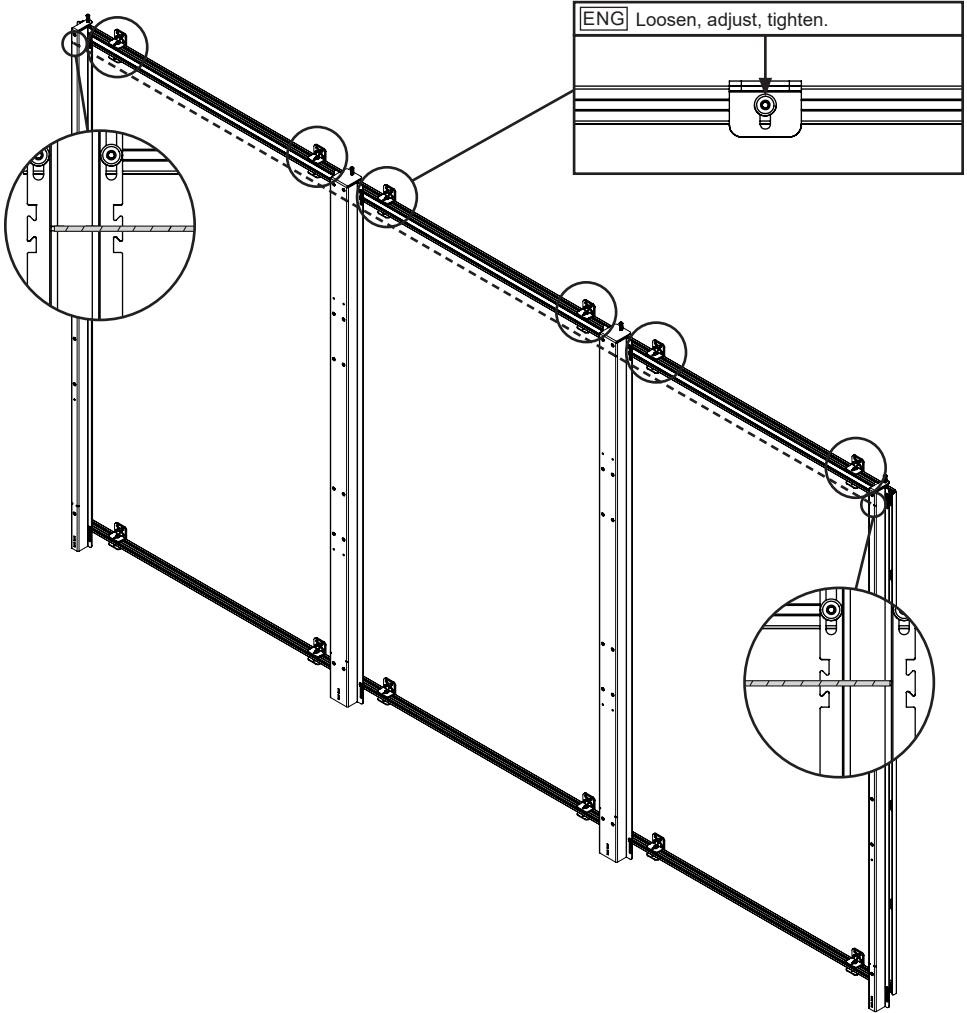
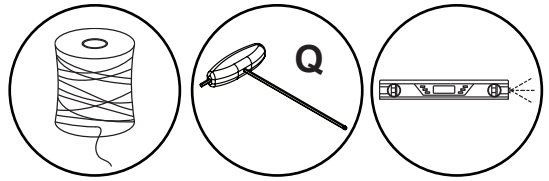

6-3

ENG With the string still attached, level the height of each column.
Align string with slot in adaptor rail as shown.

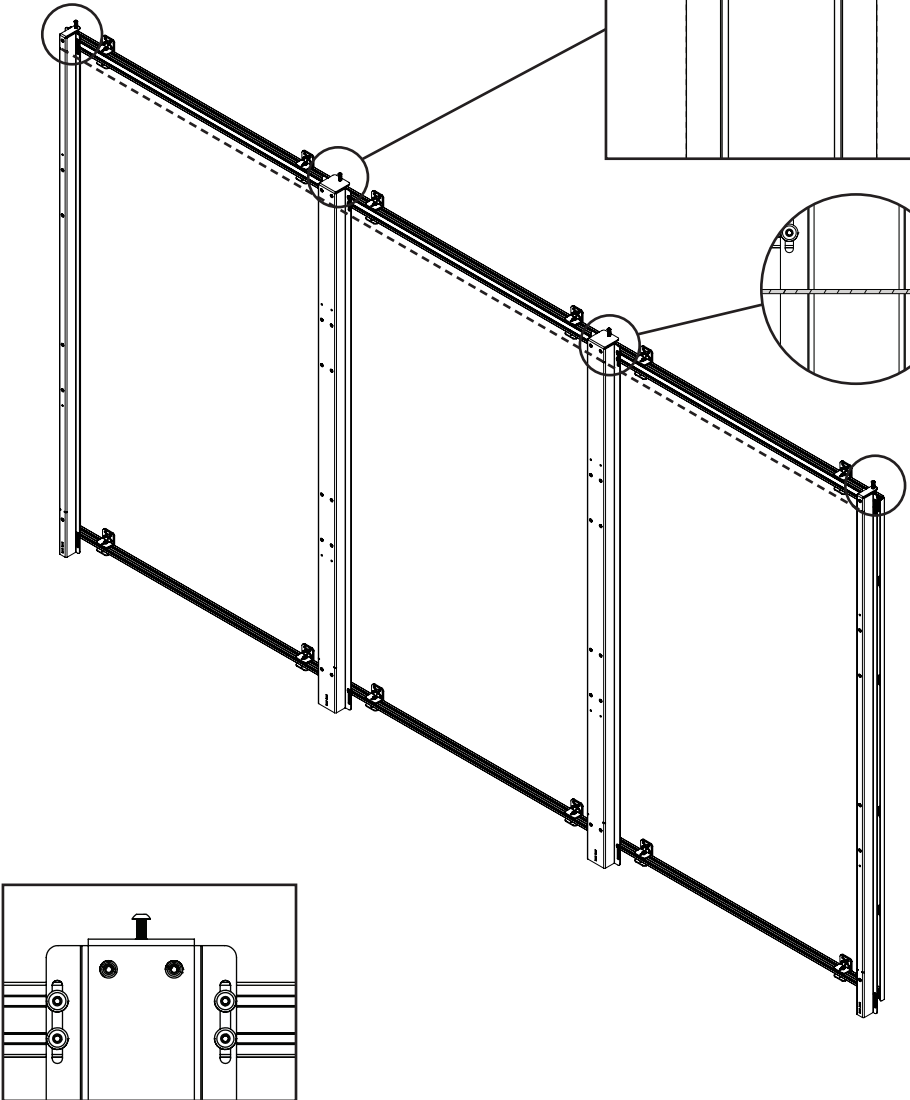
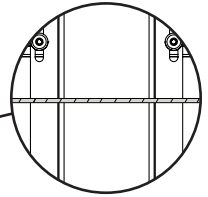
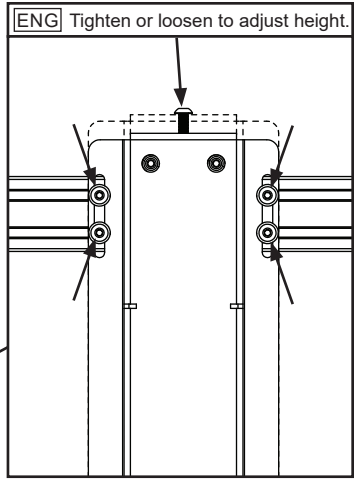
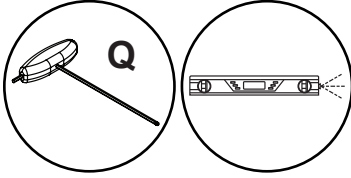

6-4

ENG Check adaptor spacing after making adjustments.

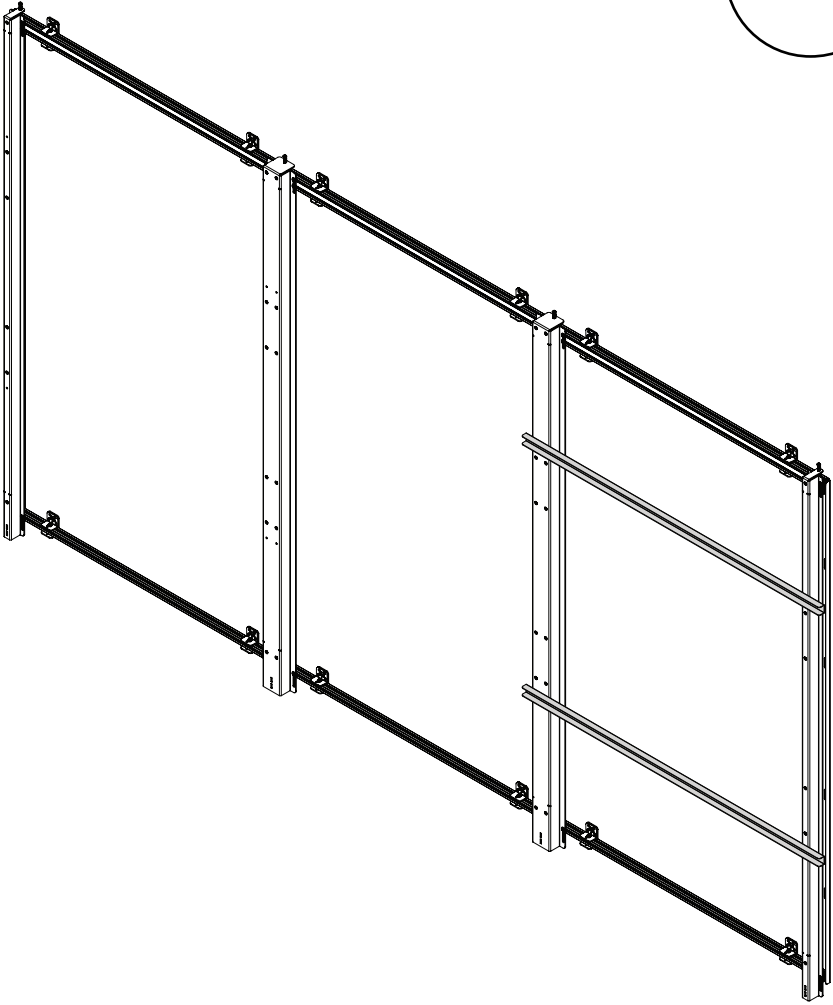
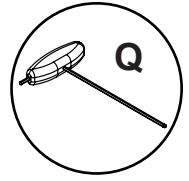

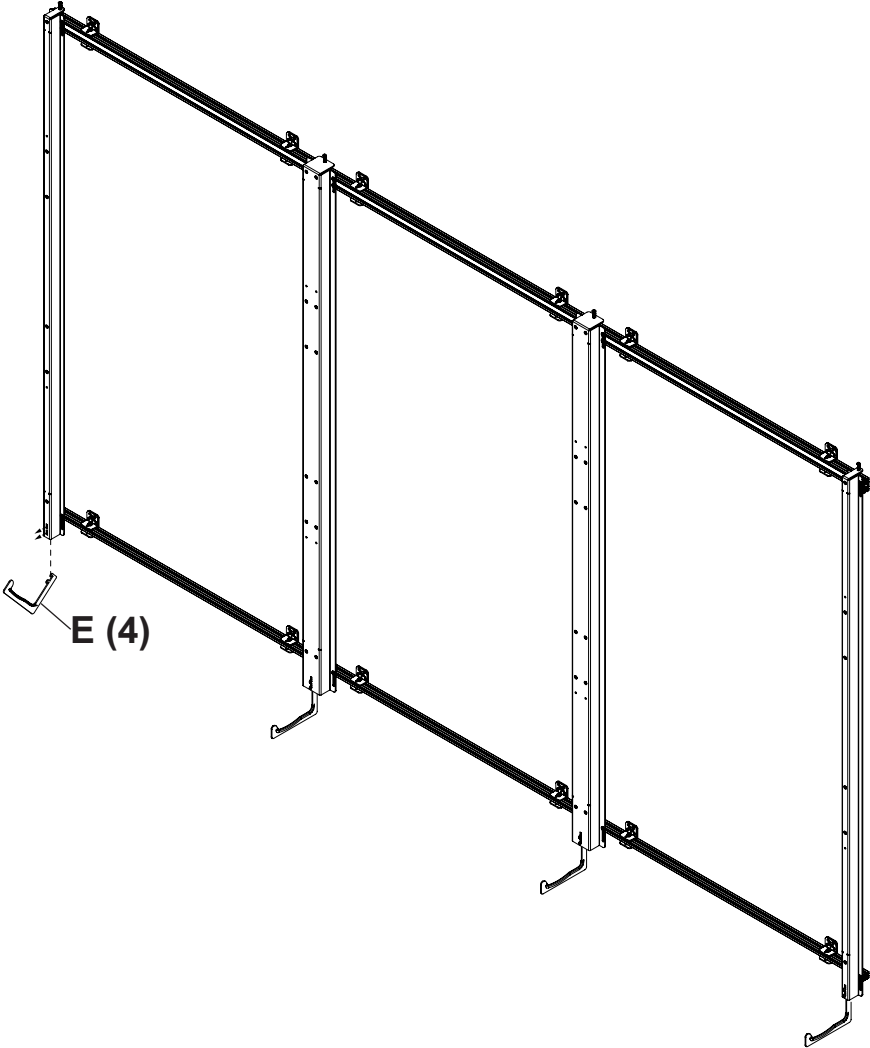

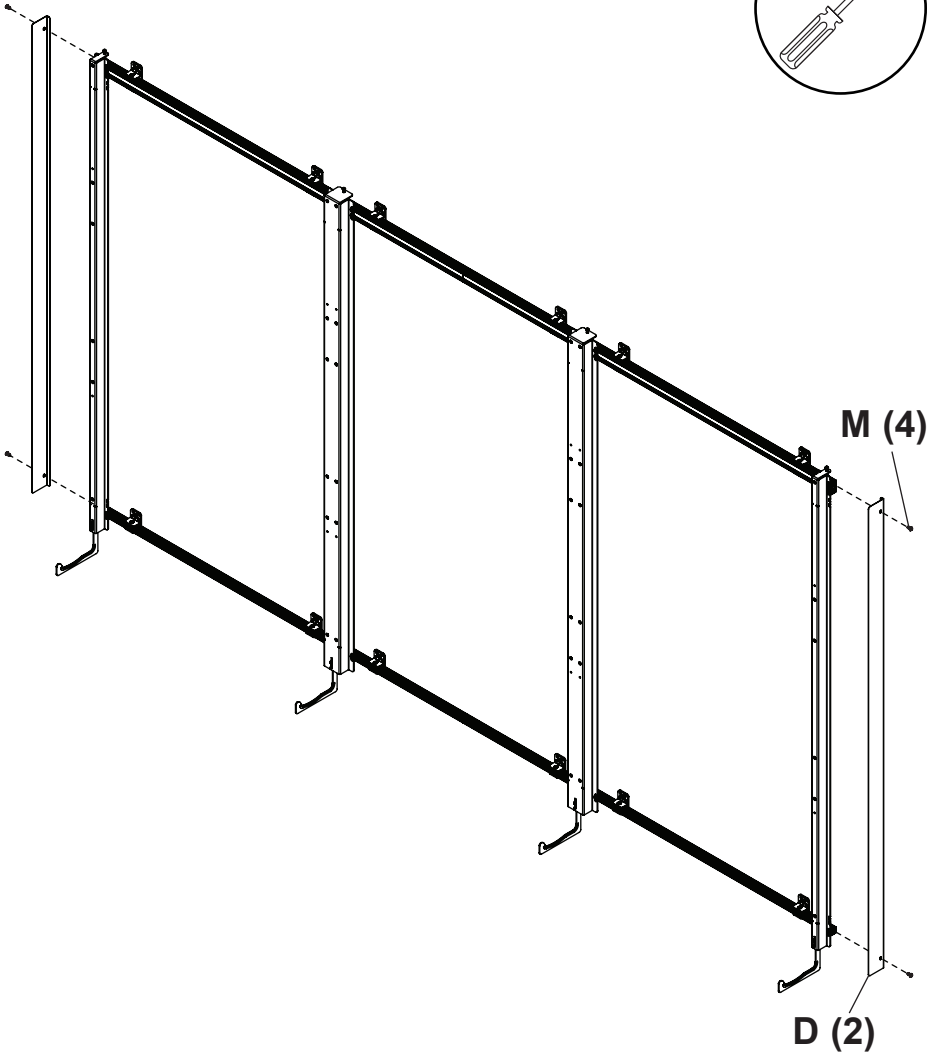
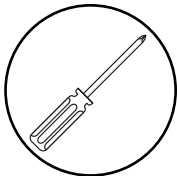

ENG Assemble display cabinets, display modules and trim per display manufacturer.

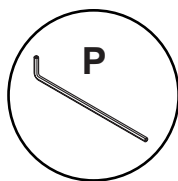

O (36)

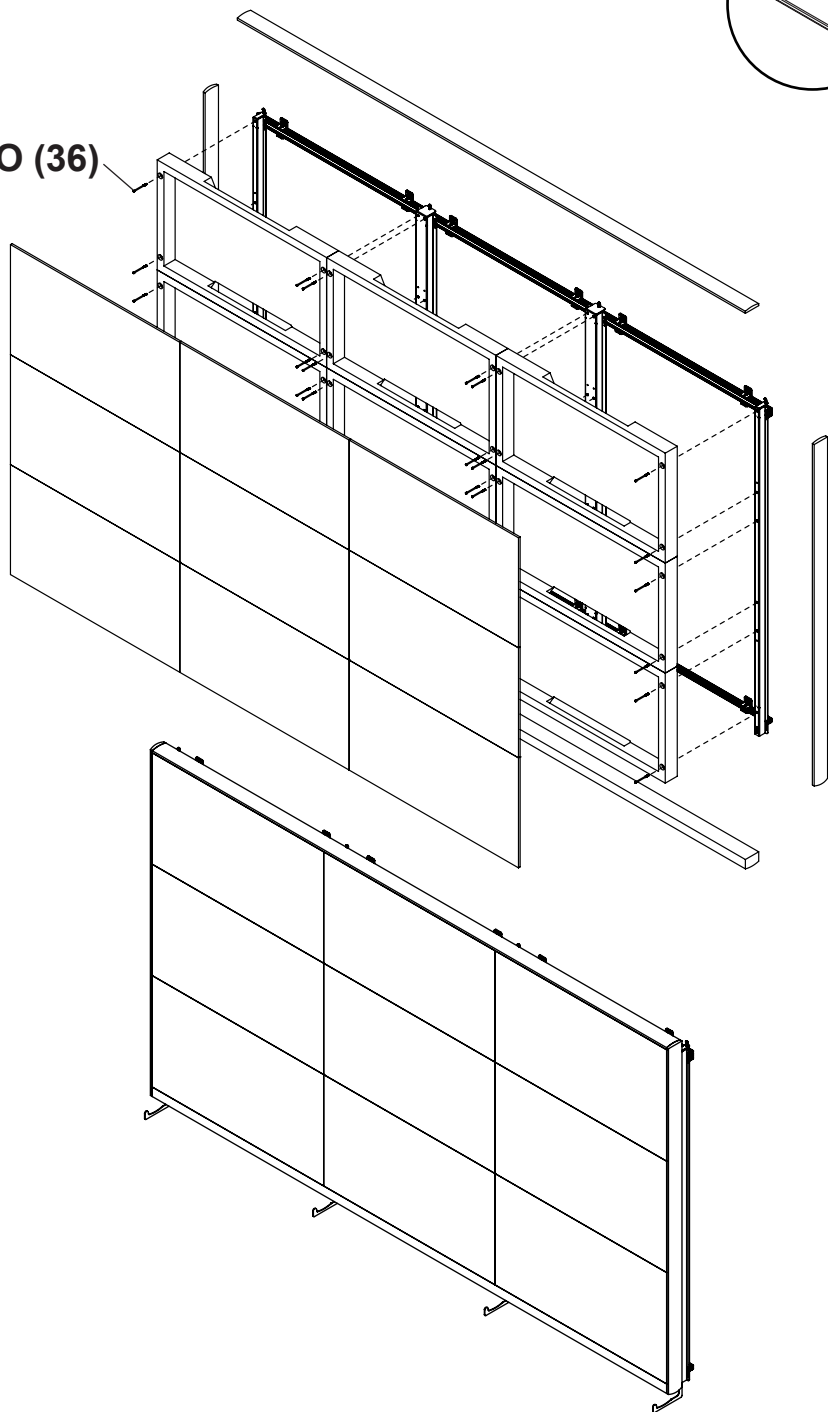

ENG Warranty
ITL Garanzia

ESP Garantía
ČES Záruka

FRN Garantie
SLK Záruka

DEU Garantie
POR Garantia

NEL Garantie
TÜR Garanti

www.peerless-av.com/warranty

peerless-AV[®]

Peerless-AV

2300 White Oak Circle
Aurora, IL 60502
Email: tech@peerlessmounts.com
Ph: (800) 865-2112
Fax: (800) 359-6500
www.peerless-av.com

© 2020, Peerless Industries, Inc.

Peerless-AV Europe

Unit 3 Watford Interchange,
Colonial Way, Watford, Herts,
WD24 4WP, United Kingdom
Customer Care
44 (0) 1923 200 100
www.peerless-av.com

© 2020, Peerless Industries, Inc.

Peerless-AV América Latina

Av. de las Industrias 413
Parque Industrial Escobedo
General Escobedo N.L., México 66062
Servicio al Cliente
01-800-849-65-77
www.peerless-av.com

© 2020, Peerless Industries, Inc.