

DS-S560-B2X2



**VESA®**  
200 x 200 up to  
600 x 400mm



**Max load**  
800lb (363kg)  
100lb per display

**SMARTMOUNT.**

## Back-to-Back Modular Video Wall Pedestal Mount 2x2 Configuration

FOR 46" TO 60" DISPLAYS UP TO 5" DEEP (127mm)

Peerless-AV's Back-to-Back Modular Video Wall Pedestal Mount encompasses an assortment of useful features that eliminate the need for extra tools and hardware, all while ensuring your application is secure and looks professional. The DS-S560-B2X2's tool-less micro adjustment provides the time saving feature you need for perfect display alignment. The built-in cable management creates a clean and clutter-free appearance. If you're looking for added stability, this mount can be mounted to concrete structures without additional wall or ceiling supports in any retail, public transportation or any other high traffic location.

- Adaptors feature a quick connect latch for automatic engagement with the mounting rails and ease of set-up
- Cable management through adjustable cable centralizing brackets
- Aluminum frame reduces the overall weight and shipping costs
- VESA® 200 x 200 up to 600 x 400mm compatible
- Designed for displays that are up to 5" deep (127mm)

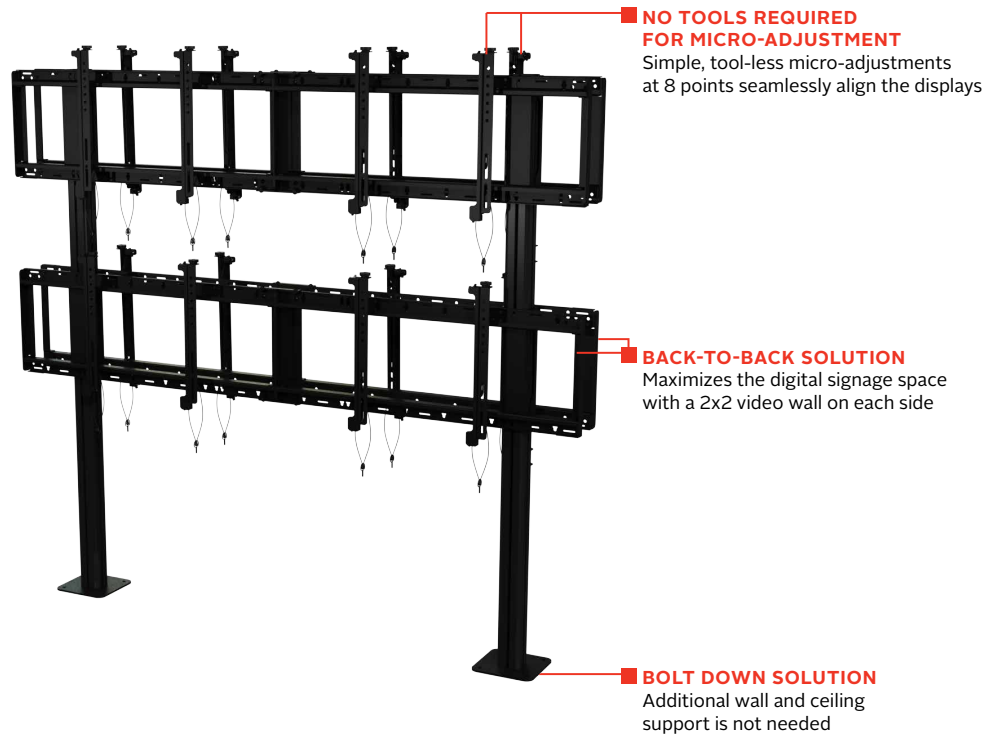

DS-S560-B2X2

SmartMount® Back-to-Back Modular Video Wall Pedestal Mount 2x2 Configuration for 46" to 60" Displays up to 5" deep (127mm)

Product Specifications

	DIMENSIONS (W x H x D)	PRODUCT WEIGHT	LOAD CAPACITY	FINISH	AVAILABLE COLORS
DS-S560-B2X2	80.61" x 75.35" x 10.35" (2047 x 1914 x 263mm)	257lb (117kg)	800lb (363kg) 100lb per display	Powder Coat	Black

Package Specifications

	PACKAGE SIZE (W x H x D)	PACKAGE SHIP WEIGHT	PACKAGE UPC CODE	PACKAGE CONTENTS	UNITS IN PACKAGE
DS-S560-B2X2	85.00" x 37.50" x 12.50" (2159 x 952 x 317mm)	345lb (157kg)	735029308218	Stand, display adaptors and hardware	1

**COMPATIBILITY FORMULA**

Display height ≤ 36"  
 Display width ≥ 40.5"  
 Display width + mount pattern width ≤ 80"

All dimensions = inch (mm)

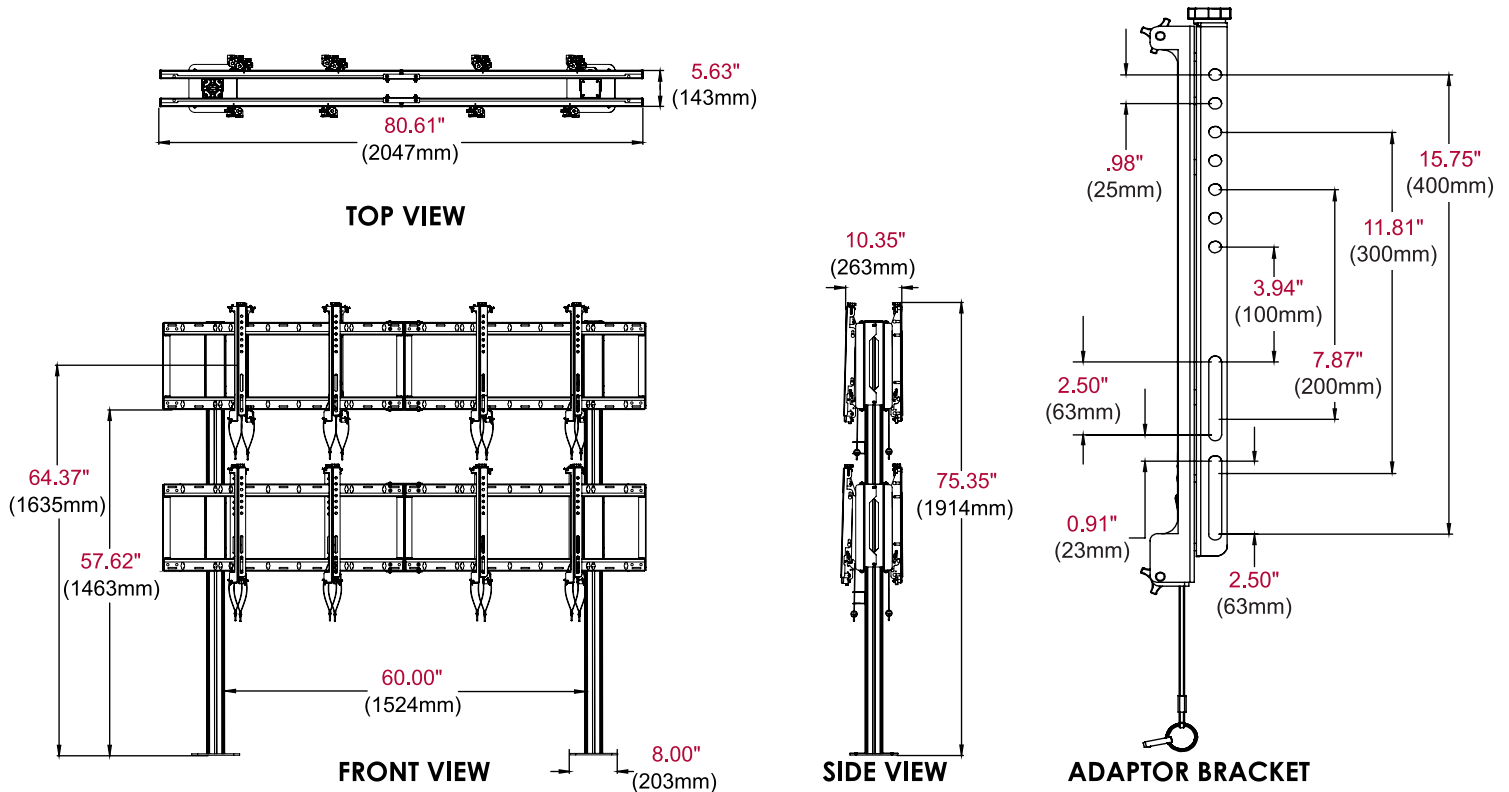

Architect Specifications

The Smartmount® Back-to-Back Modular Video Wall Pedestal Mount 2x2 Configuration shall be a Peerless-AV model DS-S560-B2X2 and shall be located where indicated on the plans. Assembly and installation shall be done according to instructions provided by the manufacturer.

Visit [peerless-av.com](http://peerless-av.com) to see the complete line of AV solutions from Peerless-AV, including outdoor displays, wireless, kiosks, digital audio, display mounts, projector mounts, carts/stands, and a full assortment of accessories.

**Peerless-AV**  
 2300 White Oak Circle  
 Aurora, IL 60502 USA  
**(800) 865-2112**  
**(630) 375-5100**  
**Fax: (800) 359-6500**

**Peerless-AV EMEA**  
 Unit 3 Watford Interchange  
 Colonial Way, Watford  
 Herts, WD24 4WP  
 United Kingdom  
**+44 (0) 1923 200100**  
**Fax: +44 (0) 1923 200101**

**Peerless-AV Latin America**  
 Ave de las Industrias 413  
 Parque Industrial Escobedo  
 Escobedo, N.L.,  
 Mexico 66062  
**+52 (81) 8384-8300**  
**Fax: +52 (81) 8384-8360**

