

peerless-AV[®]

DST940-BTB



37" - 46"
(94 - 117 cm)



75 lb x4
(34 kg) x4

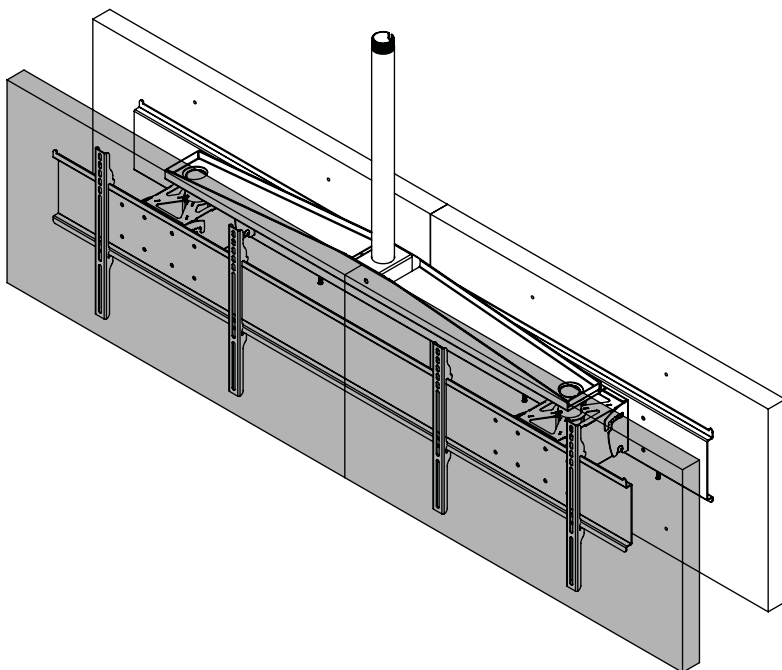

⚠ WARNING

ENG - Before installing make sure the supporting surface will support the combined load of the equipment and hardware. Screws must be tightly secured. Do not overtighten screws or damage can occur and product may fail. Never exceed the Maximum Load Capacity. Always use an assistant or mechanical lifting equipment to safely lift and position equipment. This product is intended for indoor use only. Use of this product outdoors could lead to product failure or personal injury. For support please call customer care at 1-800-865-2112.

ENG	Symbols
ESP	Símbolos
FRN	Symboles
DEU	Symbole
NEL	Symbolen
ITL	Simboli
ČES	Symboly
SLK	Symboly
POR	Símbolos
TÜR	Semboller



ENG	WARNING
ESP	ADVERTENCIA
FRN	ADVERTISSEMENT
DEU	ACHTUNG
NEL	WAARSCHUWING
ITL	AVVERTENZA
ČES	VÝSTRAHA
SLK	VÝSTRAHA
POR	AVISO
TÜR	UYARI

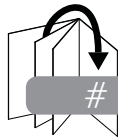

ENG	Skip to step.
ESP	Continúe con el paso.
FRN	Passez à l'étape.
DEU	Weiter mit Schritt.
NEL	Ga door naar stap.
ITL	Vai al passo.
ČES	Přeskočte na krok.
SLK	Preskočte na krok.
POR	Saltar para o passo.
TÜR	Su adima geç.



ENG	Screws must get at least three full turns and fit snug.
ESP	Los tornillos tienen que dar, por lo menos, tres vueltas completas y quedar ajustados.
FRN	Il faut effectuer au moins trois tours de vis complets et bien serrer les vis.
DEU	Schrauben sind mindestens drei volle Umdrehungen einzudrehen und müssen fest anliegen.
NEL	De schroeven moeten ten minste drie hele slagen worden aangedraaid en stevig vastzitten.
ITL	Girare tre volte le viti che devono risultare aderenti.
ČES	Šrouby se musí otočit minimálně tři plně otáčky a plně dosadnout.
SLK	Skrutky sa musia otočiť aspoň tri celé otáčky a tesne dosadnúť.
POR	Os parafusos devem completar, no mínimo, três voltas completas e ajustar-se no local.
TÜR	Vidalara en az üç tam dönüş yapmalı ve sıkı oturmalıdır.

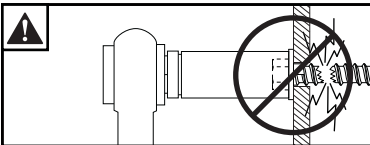

ENG	Do not overtighten screws.
ESP	No apriete de más los tornillos.
FRN	Ne pas trop serrer les vis.
DEU	Ziehen Sie die Schrauben nicht zu fest an.
NEL	Draai de schroeven niet te strak aan.
ITL	Non stringere troppo le viti.
ČES	Šrouby neutahujte příliš silně.
SLK	Skrutky neutahujte príliš silno.
POR	Não apertar demasiado os parafusos.
TÜR	Vidalara gereğinden fazla sıkmayın.

Parts List

Description	Qty	PLB-1 Part #
A tilt box	2	100-1128
B tilt plate	4	100-1047
C M5 x 12mm socket pin screw	8	520-1064
D washer	2	540-9432
E retaining collar	3	1800-375
F M4 x 12mm socket pin serrated washer screw	16	520-1079
G M4 x 25mm socket pin serrated washer screw	16	520-1082
H M6 x 12mm socket pin screw	16	520-1050
I M6 x 25mm socket pin screw	16	520-1211
J #10 washer	16	540-9400
K M8 x 25mm socket pin screw	16	520-1101
L M8 x 12mm socket pin screw	16	520-1724
M 5/16 SAE washer	32	540-9406
N spacer	32	600-1215
O 4mm allen wrench	1	560-9646
P 6" extension column	2	026-1014
Q dual cross support	1	139-1015
R 4.5" hex bolt	1	520-9548
S 3/8"-16 nylock nut	1	530-9310
T M10 x 15mm penta pin screw	16	520-9263
U adapter bracket	8	202-1655
V M10 x 2" tool driver penta pin	1	520-9260
W adapter plate	2	125-1545
X fiber washer	1	540-9431
Y M5 x 10mm phillips screw	1	520-9250
Z M8 x 50mm socket pin screw	16	521-1013

A (2)

tilt box

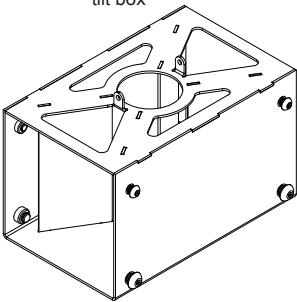

B (4)

tilt plate

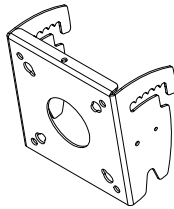

P (2)

extension column

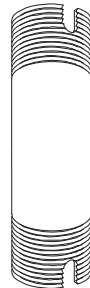

Q (1)

cross support

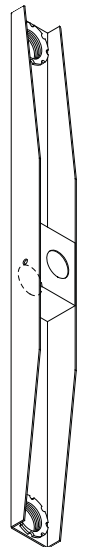

X (1)

Fiber washer

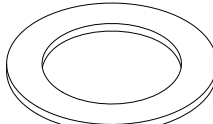

O (1)

4mm allen wrench

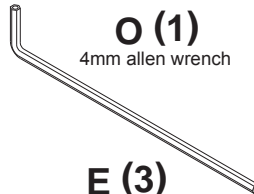

S (1)

nylock nut



C (8)

M5 x 12mm screw



D (2)

washer

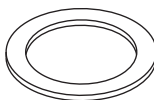

E (3)

retaining collar

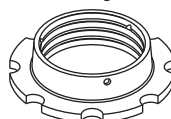

F (16)

M4 x 12mm

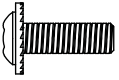

G (16)

M4 x 25mm



H (16)

M6 x 12mm

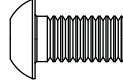

I (16)

M6 x 25mm



K (16)

M8 x 25mm

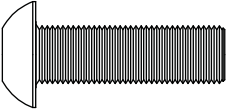

L (16)

M8 x 12mm

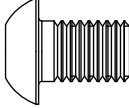

J (16)

#10 washer



M (32)

5/16 SAE washer

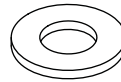

N (32)

spacer

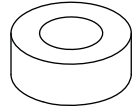

T (16)

M10 x 15mm

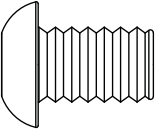

Z (16)

M8 x 50mm



Y (1)

M5 x 10mm

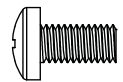

V (1)

M10 penta pin tool



U (8)

adapter bracket



R (1)

hex bolt

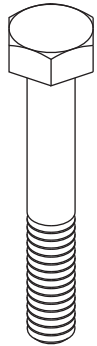

W (2)

adapter plate

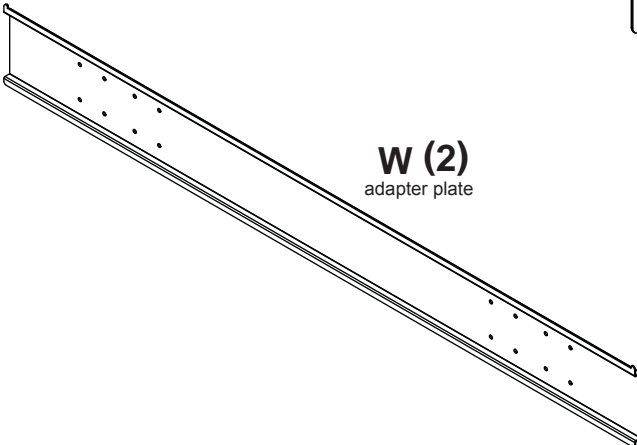

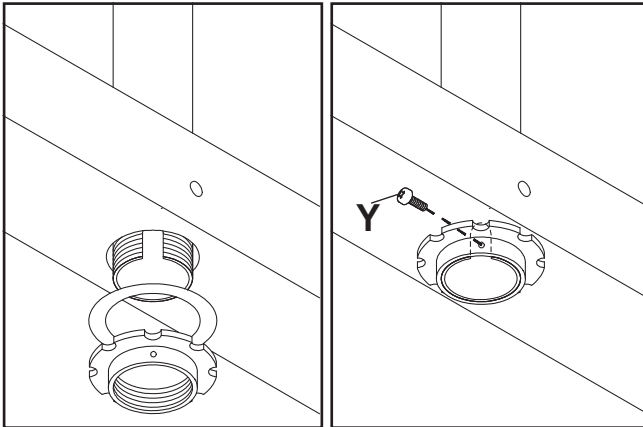
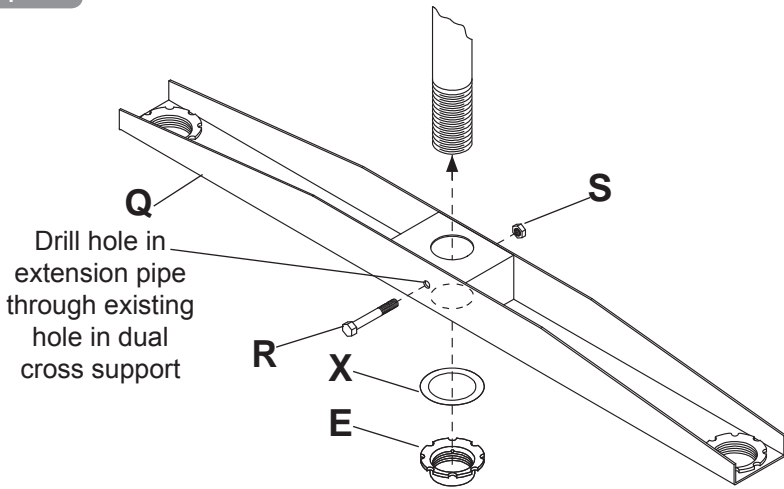

2

x2

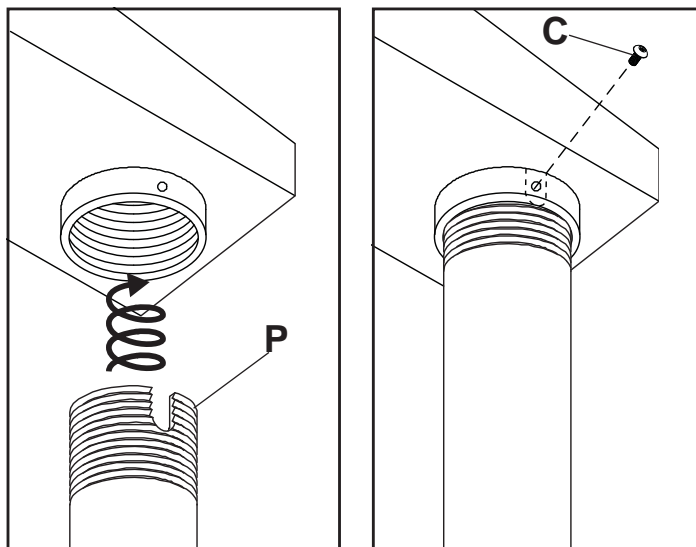

3-1

x2

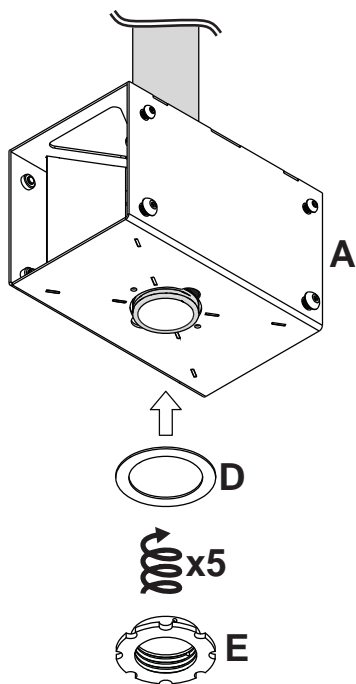

3-2

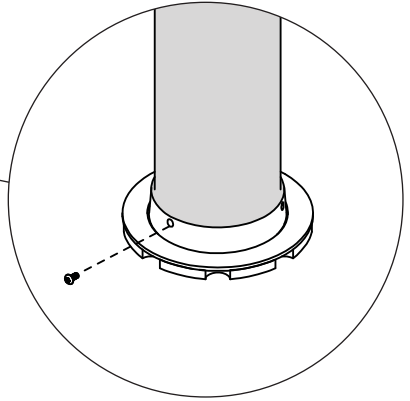
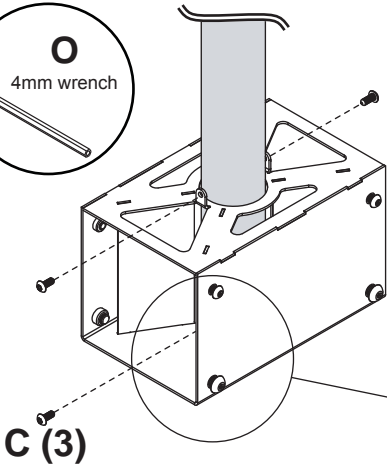
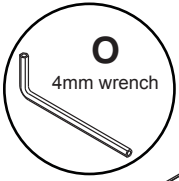

4

x2

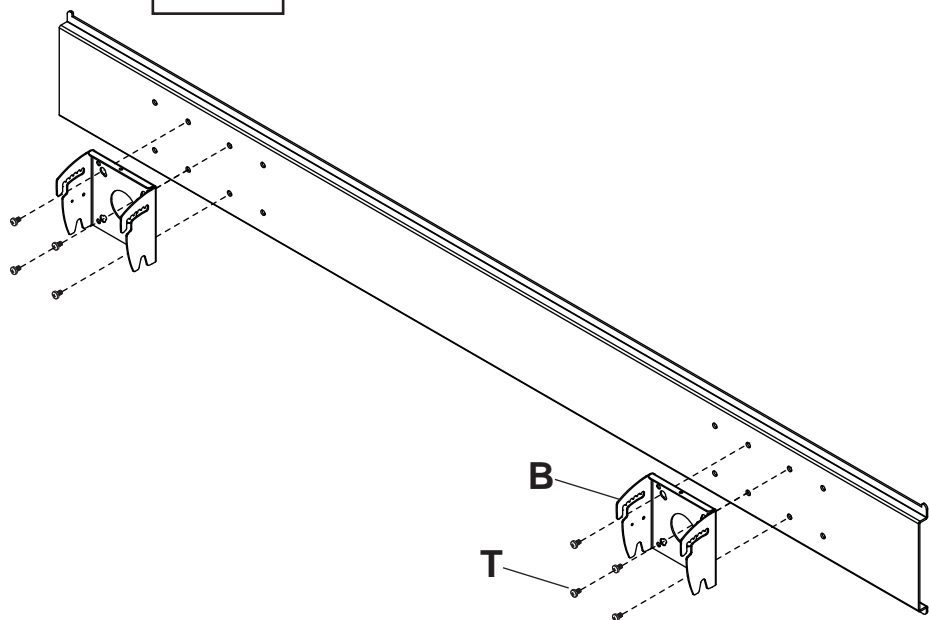

5

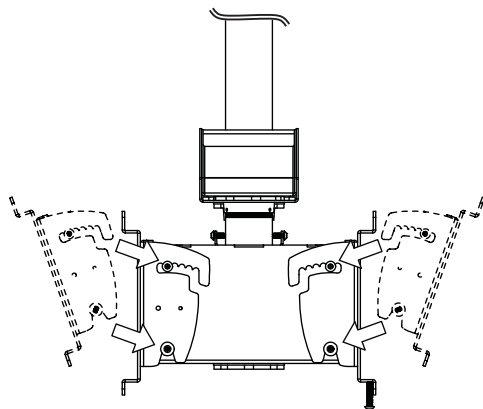

6

ENG Center adaptor brackets vertically on back of screen.

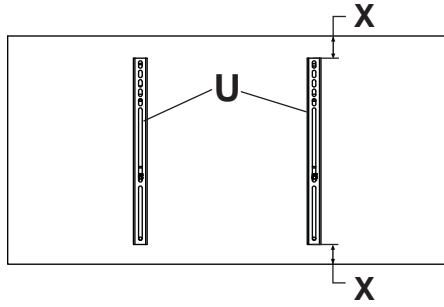

7



x4

ENG Use of spacers is OPTIONAL.

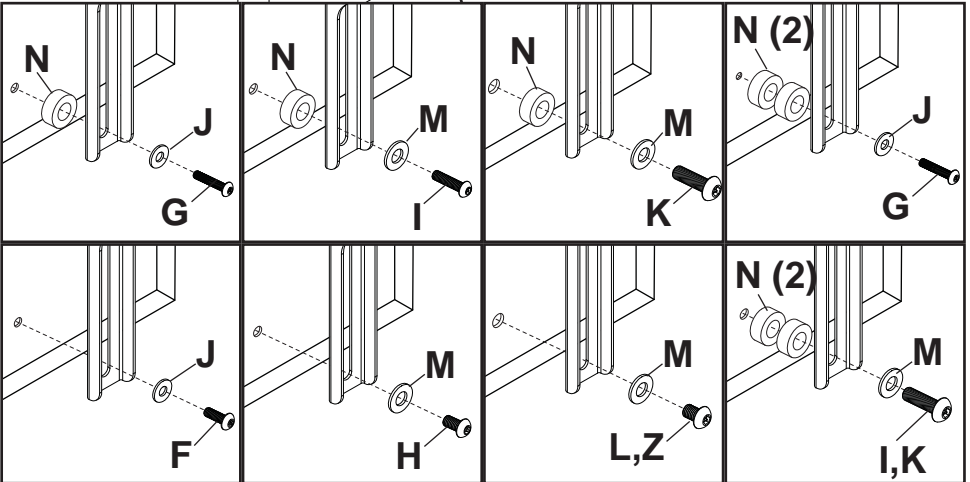
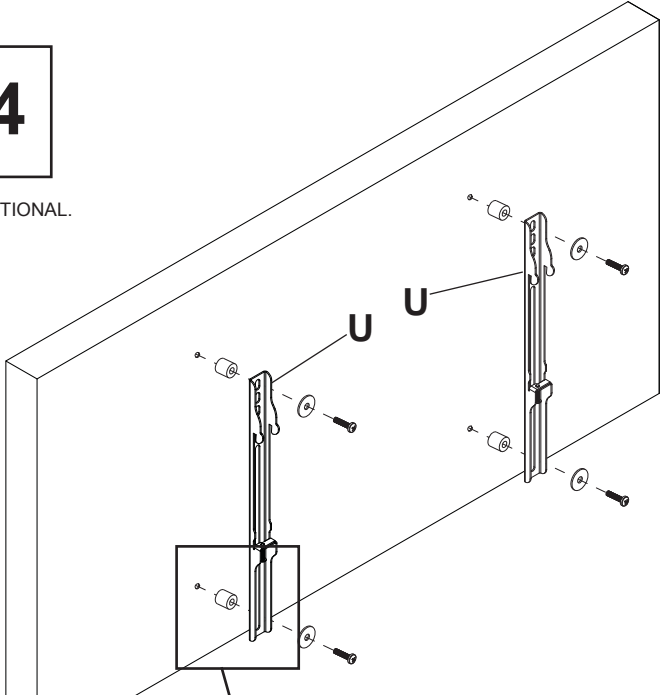

8

x4

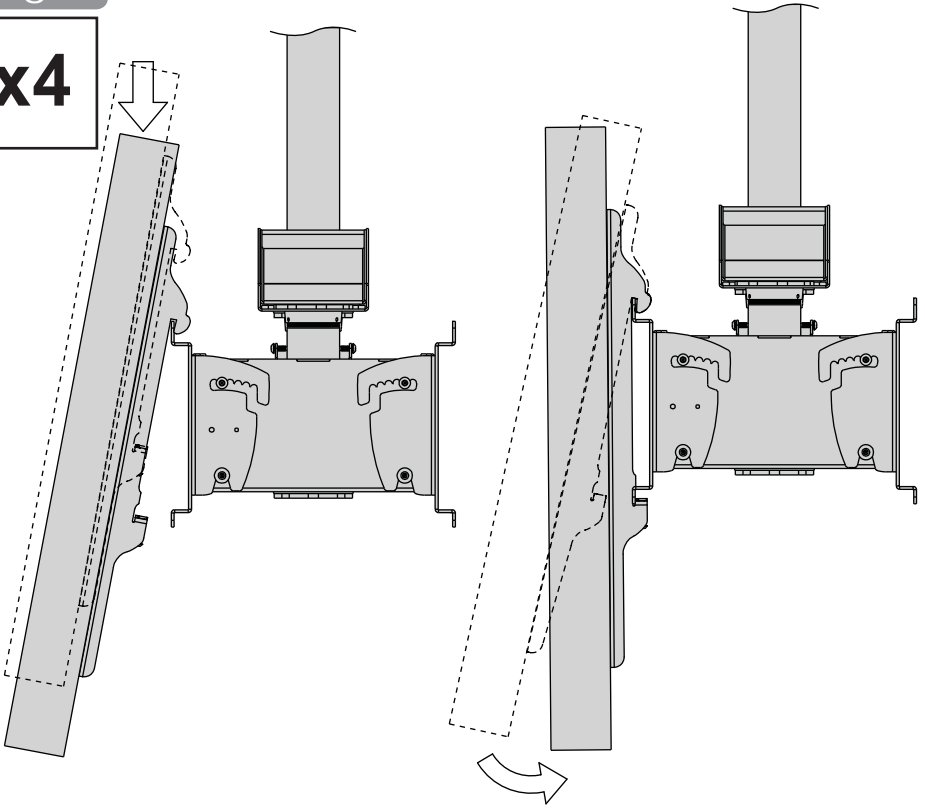

9

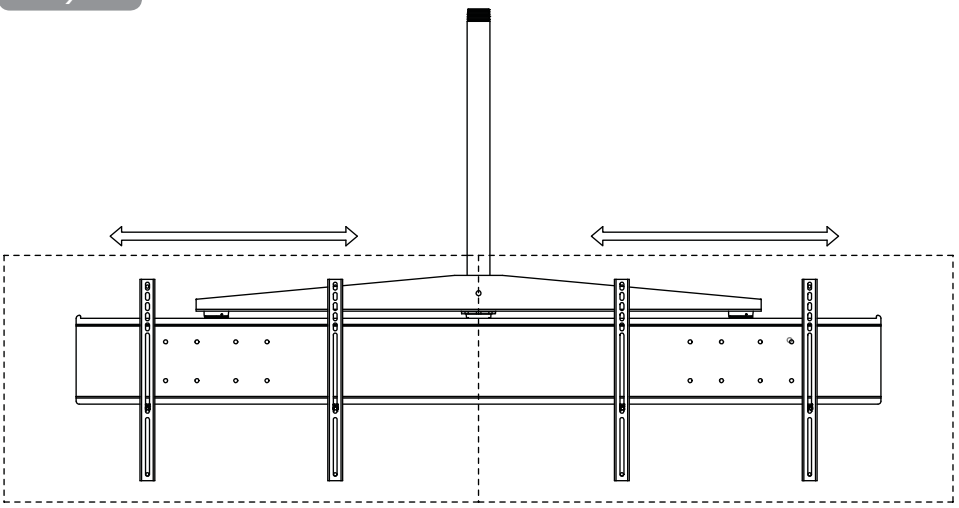

10

x4

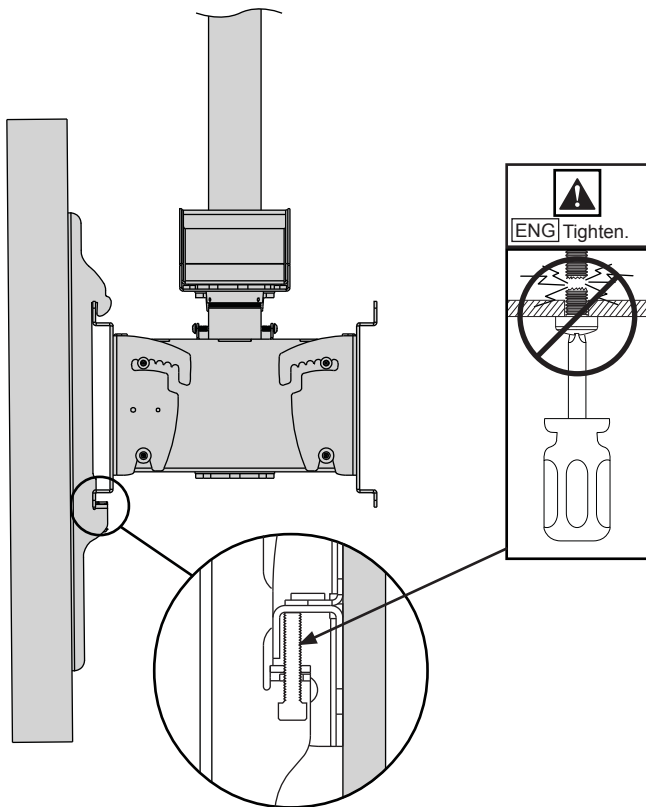

11-1

+20°/-5°

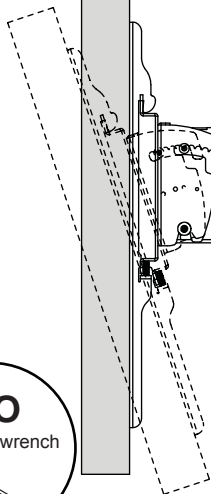

11-2

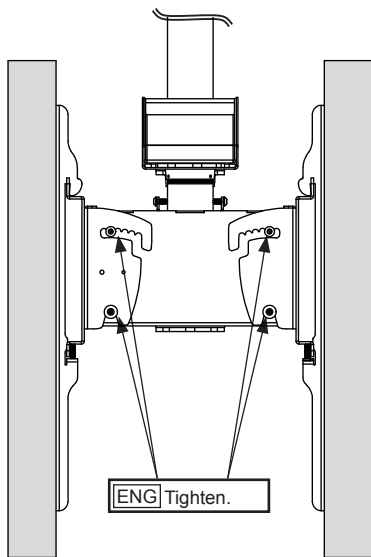

LIMITED FIVE-YEAR WARRANTY

Peerless Industries, Inc. ("Peerless") warrants to original end-users of Peerless® products will be free from defects in material and workmanship, under normal use, for a period of five years from the date of purchase by the original end-user (but in no case longer than six years after the date of the product's manufacture). At its option, Peerless will repair or replace, or refund the purchase price of, any product which fails to conform with this warranty.

In no event shall the duration of any implied warranty of merchantability or fitness for a particular purpose be longer than the period of the applicable express warranty set forth above. Some states do not allow limitations on how long a implied warranty lasts, so the above limitation may not apply to you.

This warranty does not cover damage caused by (a) service or repairs by the customer or a person who is not authorized for such service or repairs by Peerless, (b) the failure to utilize proper packing when returning the product, (c) incorrect installation or the failure to follow Peerless' instructions or warnings when installing, using or storing the product, or (d) misuse or accident, in transit or otherwise, including in cases of third party actions and force majeure.

In no event shall Peerless be liable for incidental or consequential damages or damages arising from the theft of any product, whether or not secured by a security device which may be included with the Peerless® product. Some states do not allow the exclusion or limitation of incidental or consequential damages, so the above limitation or exclusion may not apply to you.

This warranty is in lieu of all other warranties, expressed or implied, and is the sole remedy with respect to product defects. No dealer, distributor, installer or other person is authorized to modify or extend this Limited Warranty or impose any obligation on Peerless in connection with the sale of any Peerless® product.

This warranty gives specific legal rights, and you may also have other rights which vary from state to state.

The logo for Peerless-AV features the word "peerless" in a bold, lowercase, red sans-serif font. To its right, the letters "AV" are rendered in a red outline font, with a registered trademark symbol (®) to the upper right of the "V".

Peerless-AV
2300 White Oak Circle
Aurora, IL 60502
Email: tech@peerlessmounts.com
Ph: (800) 865-2112
Fax: (800) 359-6500
www.peerless-av.com

Peerless-AV Europe
Unit 3 Watford Interchange,
Colonial Way, Watford, Herts,
WD24 4WP, United Kingdom
Customer Care
44 (0) 1923 200 100
www.peerless-av.com

Peerless-AV de Mexico
Ave de las Industrias 413
Parque Industrial Escobedo
Escobedo N.L Mexico 66050
Servicio al Cliente
01-800-849-65-77
www.peerless-av.com