

ESF655P



Display size  
**42"-55"**



Max load  
**150lb (68kg)**

# Outdoor Universal Flat Mount - Portrait

FOR 42" TO 55" DISPLAYS

Peerless-AV's Outdoor Universal Flat Wall Mount offers peace of mind when mounting Peerless-AV's outdoor displays with its corrosion resistant E-Coat finish and plated hardware. In addition to simple installation with its Hook-and-Hang™ design, the open wall plate provides total wall access while keeping the display a mere 1.77" from the wall. To ensure your display is secure, tamper resistant hardware helps deter theft, offering safety and reassurance with every installation.

*The ESF655P's corrosion resistant coating allows this mount to be used outside, protecting it from all outdoor elements.*



## Additional Features

- ✓ Designed specifically for outdoor use and constructed from weatherproof materials
- ✓ Low-profile design holds display only 1.77" (45mm) from the wall for a clean application
- ✓ Safety latch ensures display is securely attached to wall plate
- ✓ Universal display adaptors easily hook onto the wall plate for fast installation
- ✓ Universal mount fits displays with mounting patterns up to 450 x 745mm (17.73"W x 29.31"H) and up to 400 x 600mm VESA® compliant
- ✓ Open wall plate design allows for total wall access, increasing electrical and cable management options

# Touchboards

205 Westwood Ave, Long Branch, NJ 07740  
Phone: 866-94 BOARDS (26273) / (732)-222-1511  
Fax: (732)-222-7088 | E-mail: sales@touchboards.com



RoHS

MADE IN USA

Patented. Utility Patent No. 7,823,850; 8,517,322; ZL200710020462.7; 1109953B; 8,348,212; 7,722,002.

info@peerless-av.com  
peerless-av.com

# peerless-AV®



<b>ESF655P</b>	Outdoor Universal Flat Mount - Portrait for 42" to 55" Displays
----------------	---

**Product Specifications**

	DIMENSIONS (W x H x D)	PRODUCT WEIGHT	LOAD CAPACITY	FINISH	AVAILABLE COLORS
<b>ESF655P</b>	19.37" x 30.25" x 1.77" (492 x 768 x 45mm)	6.8lb (3.1kg)	150lb (68kg)	E-coat covered with powder coat	Black

**Package Specifications**

	PACKAGE SIZE (W x H x D)	PACKAGE SHIP WEIGHT	PACKAGE UPC CODE	PACKAGE CONTENTS	UNITS IN PACKAGE
<b>ESF655P</b>	35.88" x 10.25" x 3.50" (911 x 260 x 89mm)	8.2lb (3.7kg)	735029304111	Wall plate, adaptor rails and mounting hardware	1

All dimensions = inch (mm)

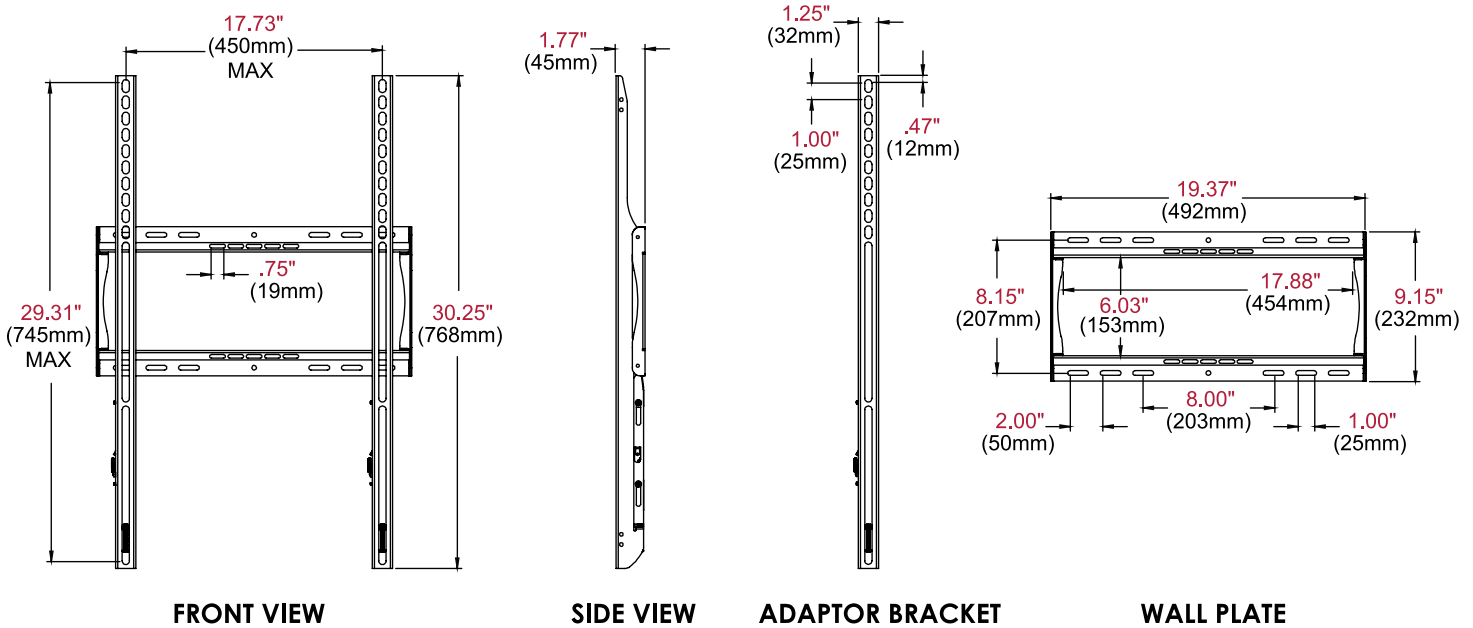

**Architect Specifications**

The Outdoor Universal Flat Mount - Portrait shall be a Peerless-AV model ESF655P and shall be located where indicated on the plans. Assembly and installation shall be done according to instructions provided by the manufacturer.

Visit [peerless-av.com](http://peerless-av.com) to see the complete line of AV solutions from Peerless-AV, including outdoor displays, wireless, kiosks, digital audio, display mounts, projector mounts, carts/stands, and a full assortment of accessories.

**Peerless-AV**  
 2300 White Oak Circle  
 Aurora, IL 60502 USA  
**(800) 865-2112**  
**(630) 375-5100**  
**Fax: (800) 359-6500**

**Peerless-AV Europe**  
 Unit 3 Watford Interchange  
 Colonial Way, Watford  
 Herts, WD24 4WP  
 United Kingdom  
**+44 (0) 1923 200100**  
**Fax: +44 (0) 1923 200101**

**Peerless-AV de México**  
 Ave de las Industrias 413  
 Parque Industrial Escobedo  
 Escobedo, N.L.,  
 Mexico 66050  
**+52 (81) 8384-8300**  
**Fax: +52 (81) 8384-8360**

