



FS-MIS38426

For Samsung Super Ultra Wide Curved Monitor

43": LC43J890DKNXZA

49": C49HG90DMN

49": LC49J890DKNXZA

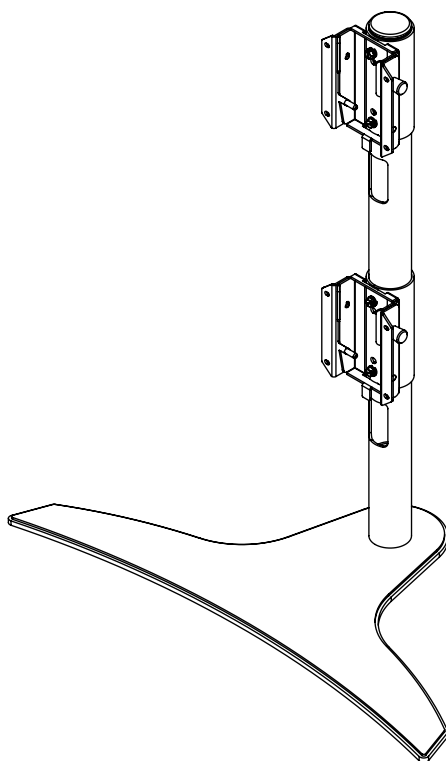
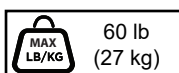

⚠ WARNING

ENG - Do not begin to install product until you have read and understood the instructions and warnings contained in this user guide. Always use an assistant or mechanical lifting equipment to safely lift and position equipment. This product must be installed onto flat, hard, level surface to prevent tipping. Use with heavier displays may result in instability causing tip over resulting in death or serious injury. The stand is not affixed or secured to the surface, and may therefore tip over and/or fall if screen and/or stand is shaken or hit. This product is intended for indoor use only. Use of this product outdoors could lead to product failure or personal injury. Screws must be tightly secured. Do not overtighten screws or damage can occur and product may fail. Never exceed the Maximum Load Capacity. Be careful not to pinch fingers when operating the mount. Death or serious injury may occur when children climb on audio and/or video equipment furniture. A remote control or toys placed on the furnishing may encourage a child to climb on the furnishing and as a result the furnishing may tip over on to the child. Relocating audio and/or video equipment to furniture not specifically designed to support audio and/or video equipment may result in death or serious injury due to the furnishing collapsing or over turning onto a child. For support please call customer care at 1-800-865-2112.

ENG Symbols



ENG WARNING



ENG Skip to step.



ENG Screws must get at least three full turns and fit snug.

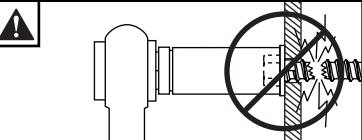

ENG Do not overtighten screws.



ENG Display center.



ENG Listen

ENG Tools Needed for Assembly.

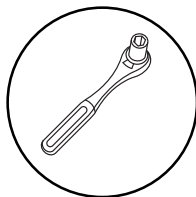
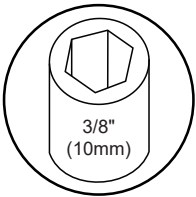

ENG To properly tighten screws: Tighten until screw head makes contact, then tighten another 1/2 turn. Do not overtighten screws.

1

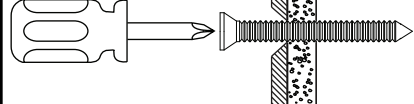

2

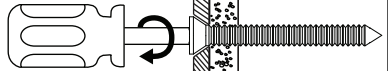

3

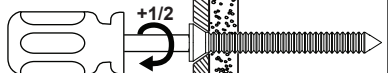

4



ENG Parts (Before beginning, make sure you have all parts shown below).

Parts List		
Description	Qty	Part #
A base plate	1	091-1207
B adapter bracket	2	091-1211
C right adapter bracket	2	091-1217
D left adapter bracket	2	091-1218
E support tube	1	091-1219
F M6 x 6mm hex set screw	2	510-9150
G M4 x 10mm socket pin screw	8	520-1060
H 1/4-20 x 3/8 socket pin	2	520-1109
I 1/4-20 x 3/4 hex head screw	4	520-1321
J 1/4 x 1/2 x .068 split washer	4	540-9402
K 4mm allen wrench	1	560-9646
L foam strip 48"	1	570-1170
M adhesive pad	6	570-1168
N 3mm allen wrench	1	560-0194

A (1)
base plate

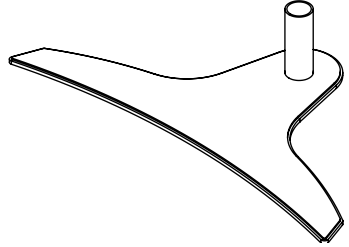

B (2)

adapter bracket

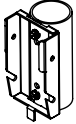

C (2)

right adapter bracket



D (2)

left adapter bracket



E (1)

support tube

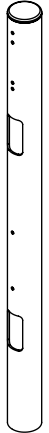

G (8)

M4 x 10mm socket pin screw

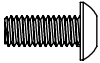

K (1)

4mm allen wrench



L (1)

foam strip



H (2)

1/4-20 X 3/8 socket pin screw

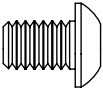

F (2)

M6 x 6mm hex set screw



M (6)

adhesive pad

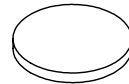

I (4)

1/4-20 x 3/4 hex head screw

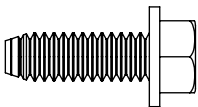

J (4)

1/4 x 1/2 x .068 split washer

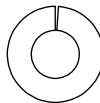

N (1)

3mm allen wrench



1

ENG Attach adhesive pads to the bottom of the base plate.

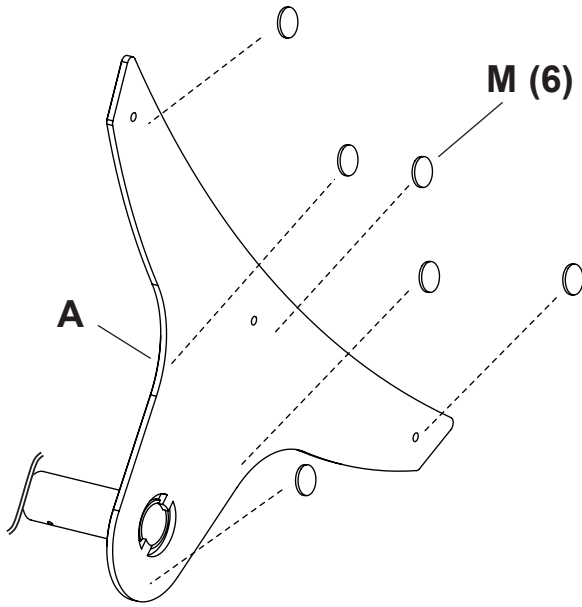

2

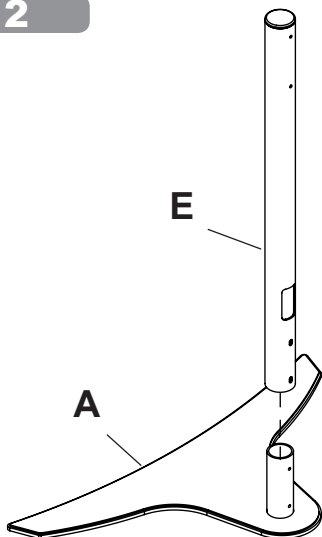

2-1

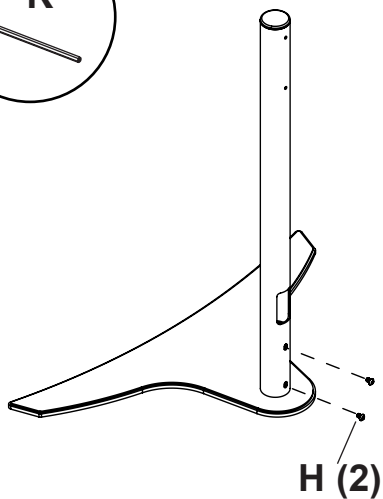
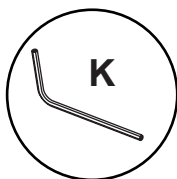

3

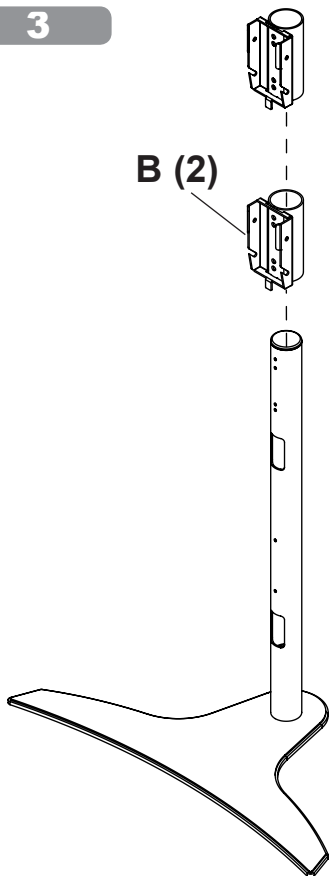

3-1

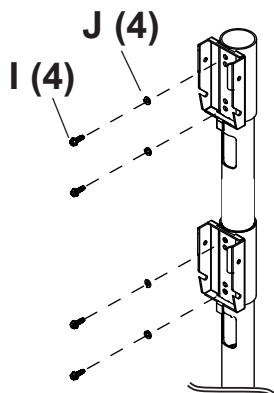
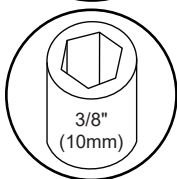

3-2

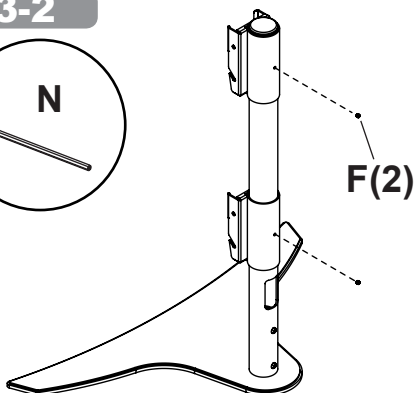
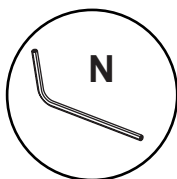

4

ENG Top display

ENG Note orientation of tab

ENG Samsung Super Ultra Wide Curved Monitor
43" (LC43J890DKNXZA), 49" (C49HG90DMN), 49" (LC49J890DKNXZA)
sold separately

4-1

ENG Note orientation of tab

ENG Bottom display

5

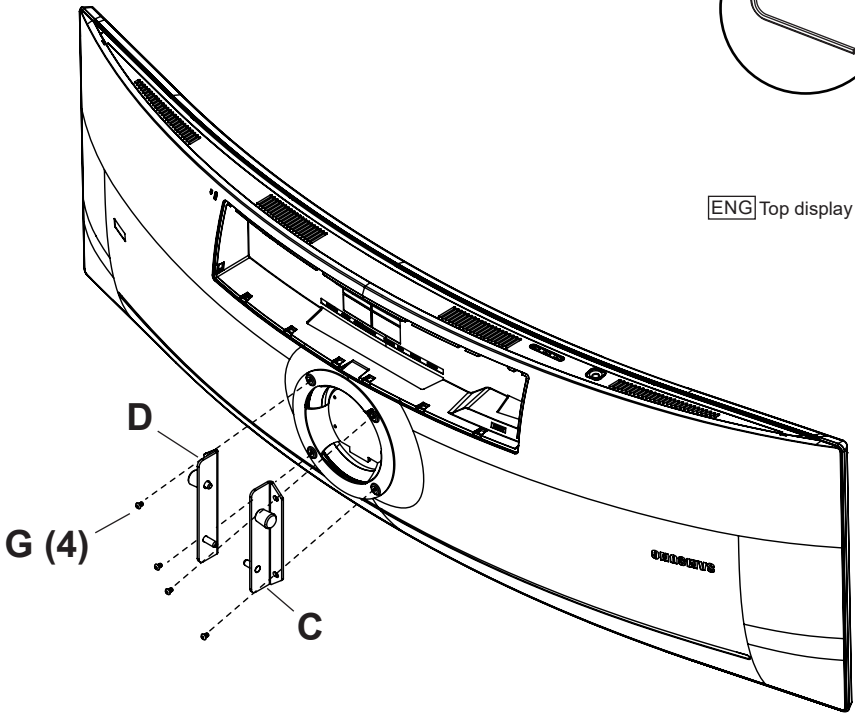
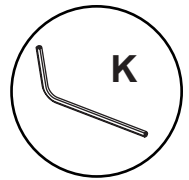

ENG Top display

5-1

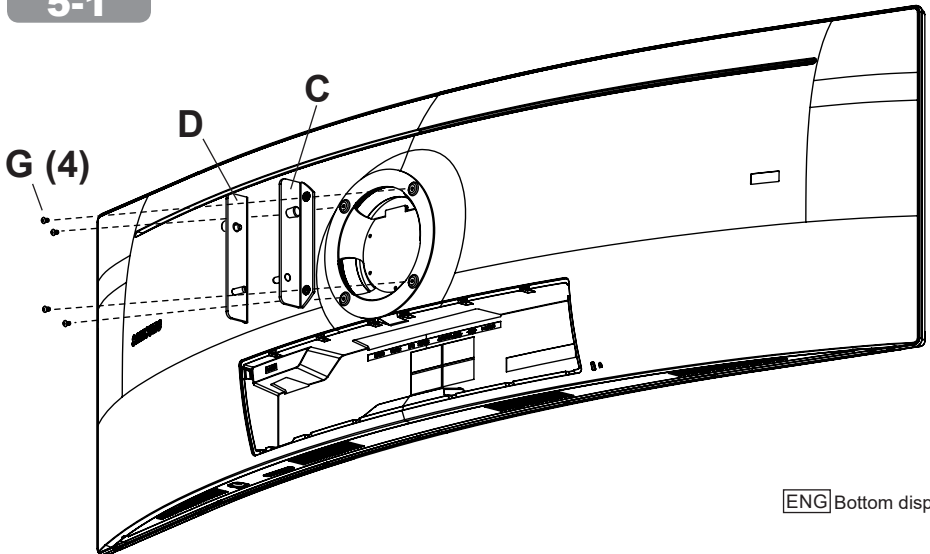

ENG Bottom display

6

ENG Attach foam strip to the top edge of bottom display.

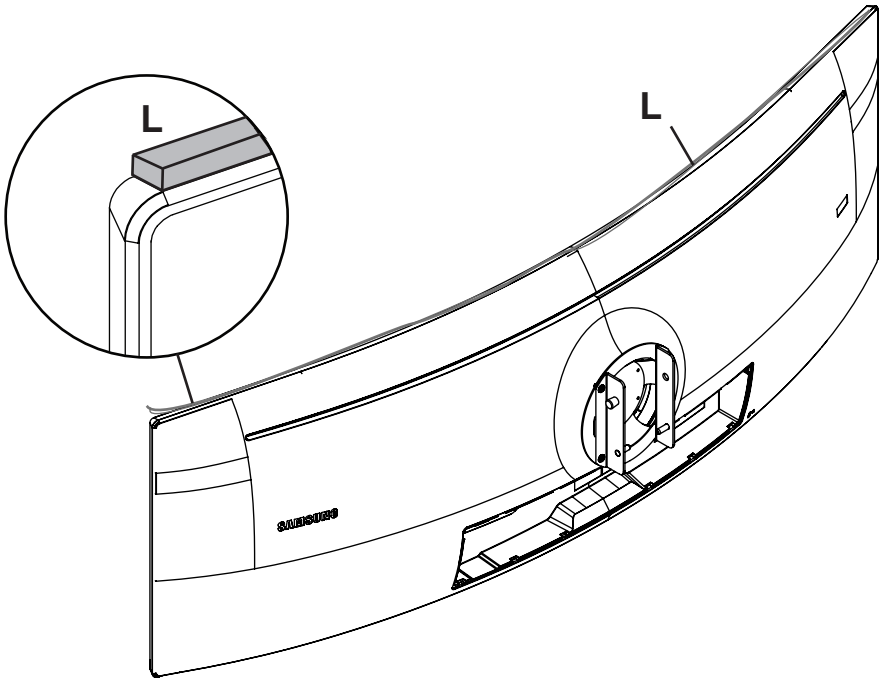
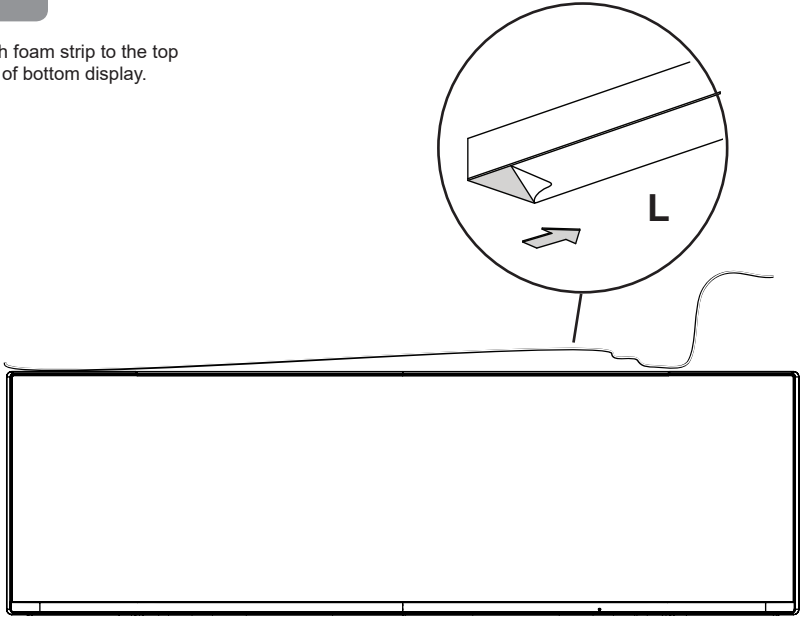

7

ENG Attach top display first.

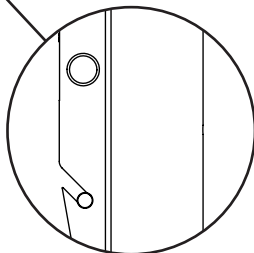
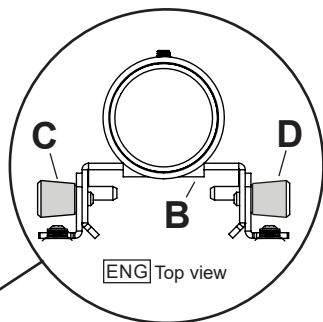
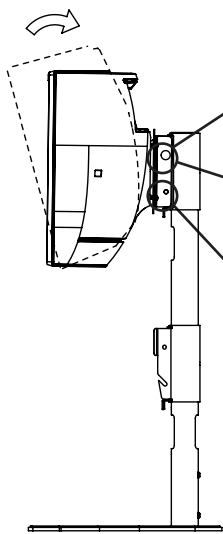
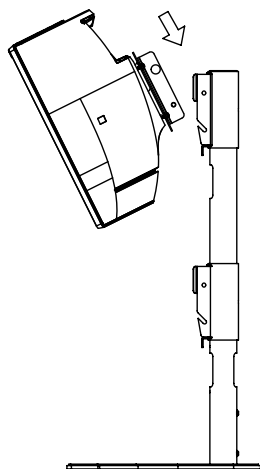

7-1

ENG Attach bottom display.

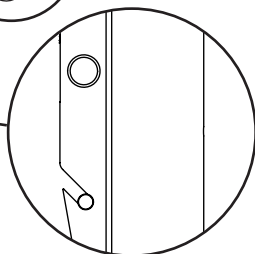
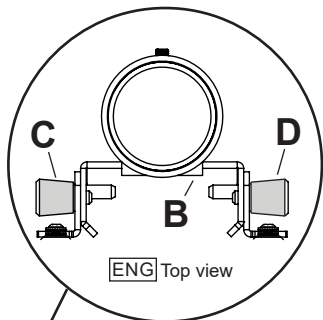
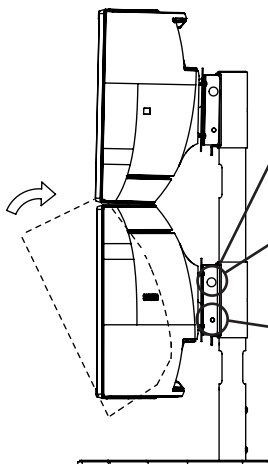
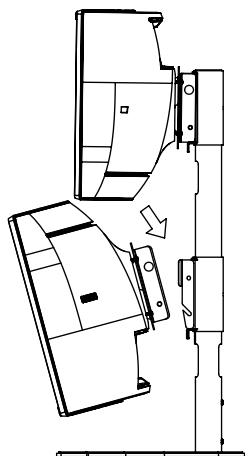

▲ WARNING

ENG Must support weight/front of display when disengaging quick release knobs from support tube.

8

ENG QUICK RELEASE; Pull knobs to disengage.

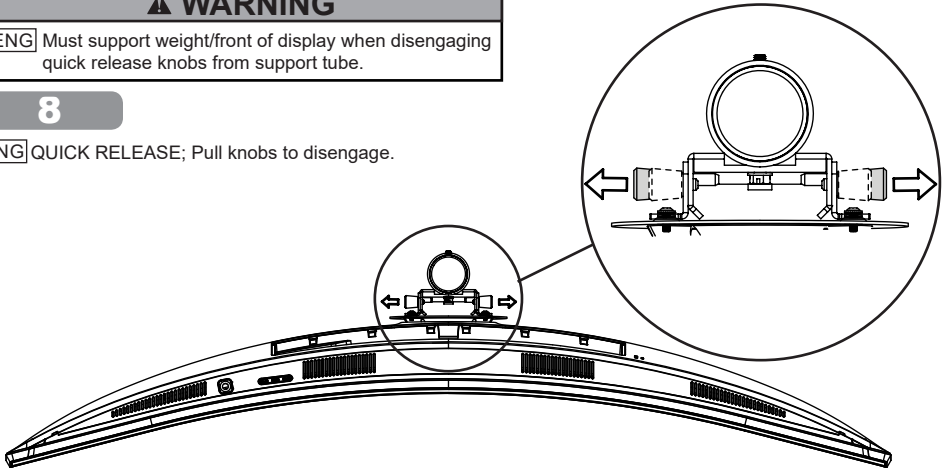

8-1

ENG Support display, tilt forward.

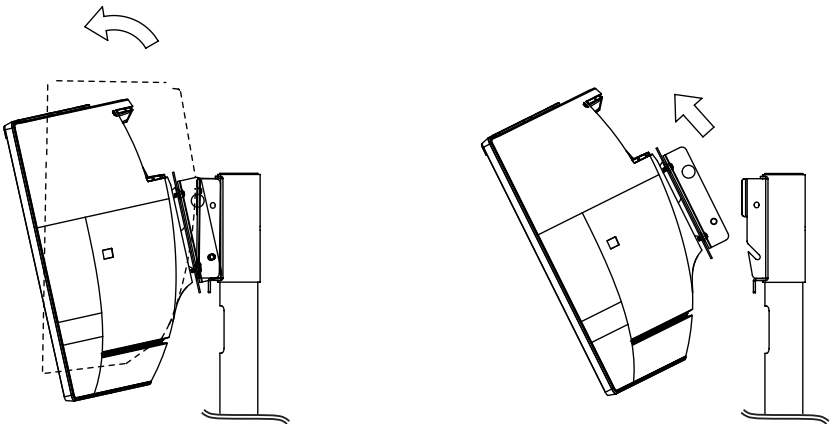
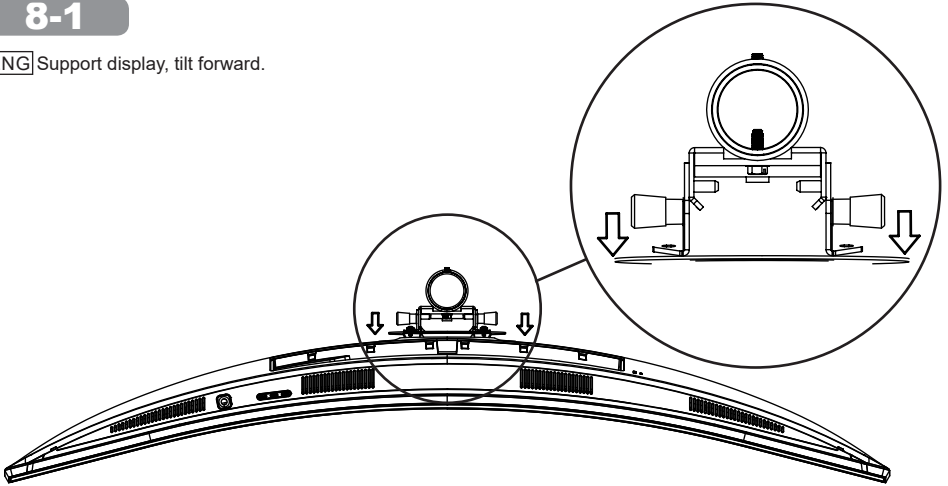

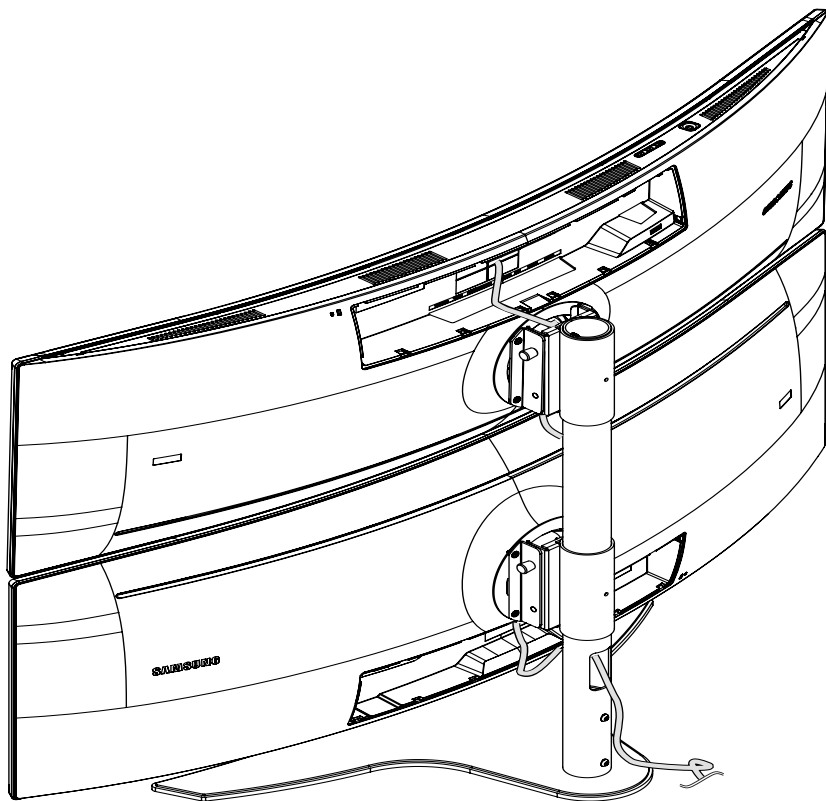

LIMITED FIVE-YEAR WARRANTY

Peerless Industries, Inc. ("Peerless-AV") warrants to original end-users that each Peerless-AV® mounting product will be free from defects in material and workmanship, under normal use, for the applicable warranty period (from date of the original installation of the product). At its option, Peerless-AV will repair or replace, or refund the purchase price of, any product which fails to conform with this warranty.

Any implied warranty of merchantability or fitness for a particular purpose shall be limited to the period of the express warranty set forth below.

In no event shall Peerless-AV be liable for incidental or consequential damages, whether or not secured by a security device which may be included with the product.

Some states do not allow limitations on how long an implied warranty lasts, or the exclusion of incidental or consequential damages, so the above limitation and/or the above exclusion may not apply to you.

This warranty does not cover damage caused by incorrect selection, installation or the failure to follow Peerless-AV instructions or warnings when installing, using or storing the product.

This warranty gives specific legal rights, and you may also have other rights which vary from state to state. To make a warranty claim in North America, contact Peerless-AV customer care at 1-800-865-2112. See complete global warranty information for regions outside North America at www.peerless-av.com/en-uk/customer-care/warranties-returns.

The logo for Peerless-AV features the word "peerless" in a bold, lowercase, red sans-serif font. To its right, the letters "AV" are rendered in a red outline font, with a registered trademark symbol (®) to the upper right of the "V".

Peerless-AV

2300 White Oak Circle
Aurora, IL 60502
Email: tech@peerlessmounts.com
Ph: (800) 865-2112
Fax: (800) 359-6500
www.peerless-av.com

© 2019, Peerless Industries, Inc.

Peerless-AV Europe

Unit 3 Watford Interchange,
Colonial Way, Watford, Herts,
WD24 4WP, United Kingdom
Customer Care
44 (0) 1923 200 100
www.peerless-av.com

© 2019, Peerless Industries, Inc.

Peerless-AV de Mexico

Ave de las Industrias 413
Parque Industrial Escobedo
Escobedo N.L Mexico 66062
Servicio al Cliente
01-800-849-65-77
www.peerless-av.com

© 2019, Peerless Industries, Inc.