

LCT620A LCT620A-G



Monitor size
up to 29"



Max load
8.4 to 17.8lb
(3.8 to 8.1kg)

Desktop Monitor Arm Mount

FOR UP TO 29" MONITORS

The LCT620A and LCT620A-G Desktop Monitor Mounts feature an attractive height adjustable articulating arm that provide perfect ergonomics with optimum monitor positioning for virtually all users. Choose between a clamp-on or grommet mounting base for limitless mounting options on any desktop or countertop surface between ½" to 2" (12 to 55mm) thick.

Peerless-AV's desktop monitor mounts offer flexible monitor positioning, so the proper viewing angle can be found for all users.



Additional Features

- ✓ Articulating arm allows monitor to be adjusted to the perfect ergonomic position to help reduce eye, back and neck strain
- ✓ Accommodates different monitor weights ranging from 8.4 to 17.8lb (3.8 to 8.1kg)
- ✓ Smooth and effortless arm movement provided by bushings at all pivot points
- ✓ Compatible with VESA® 75 x 75mm and 100 x 100mm mounting patterns
- ✓ Monitor can be positioned anywhere from 0.25" to 18.50" (6 to 470mm) above the desktop surface measured at the center of the adaptor
- ✓ Both style mounting bases accommodate a desktop or counter thickness of 0.2" to 2.2" (5-55mm) thick
- ✓ Expertly finished polished aluminum arm and black base with chrome pole
- ✓ Integrated cable management provides clean, professional installation finish

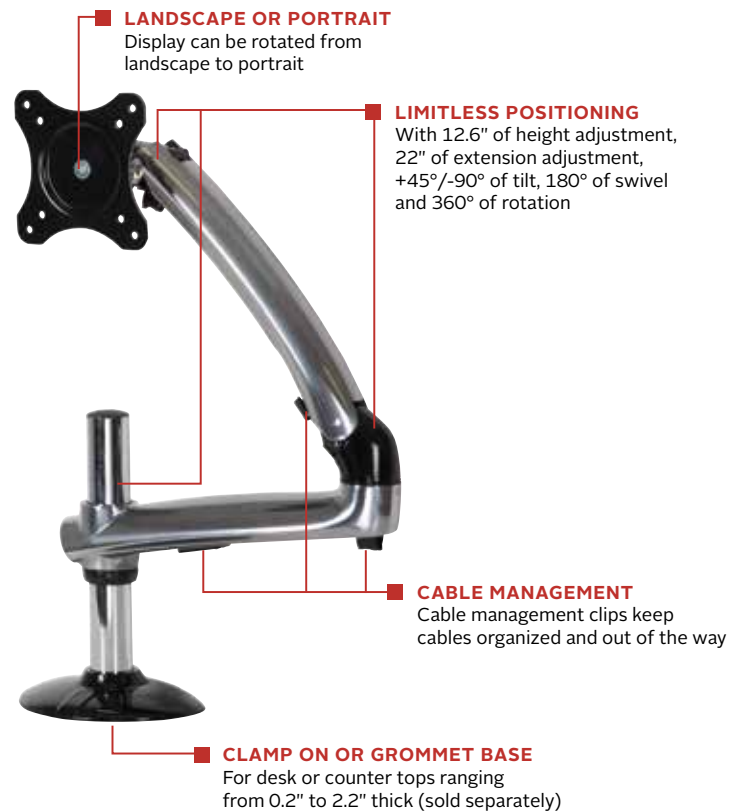

Touchboards

205 Westwood Ave, Long Branch, NJ 07740
Phone: 866-94 BOARDS (26273) / (732)-222-1511
Fax: (732)-222-7088 | E-mail: sales@touchboards.com



RoHS



TAA COMPLIANT



LCT620A-G's Grommet base works with through holes in the desk or counter top



LCT620A's Clamp on base easily clamps to edge desk or counter top



Cable management keeps a clean appearance

Model Numbers

WARRANTY: Limited 5-year

LCT620A	Clamp-on Base Desktop Monitor Arm Mount for up to 29" Monitors
LCT620A-G	Grommet Base Desktop Monitor Arm Mount for up to 29" Monitors

Product Specifications

	DIMENSIONS (W X H X D)	PRODUCT WEIGHT	LOAD CAPACITY	FINISH	AVAILABLE COLORS
LCT620A LCT620A-G	(See Drawing)	11.00lb (5kg)	8.4 to 17.8lb (3.8 to 8.1kg)	High Gloss	Polished Aluminum with Black base and accents

Package Specifications

	PACKAGE SIZE (W x H x D)	PACKAGE SHIP WEIGHT	PACKAGE UPC CODE	PACKAGE CONTENTS	UNITS IN PACKAGE
LCT620A LCT620A-G	17.76" x 5.12" x 16.34" (451 x 130 x 415mm)	11.66lb (5.3kg)	735029279891 735029304005	Base with Pole, Arm w/adaptor, Hardware & Mounting instruction	1

Accessories

ACC328:	Laptop Tray
ACC450:	VESA® 200 x 200mm Accessory Adaptor Plate
ACC918:	Security Fasteners
PTM200:	Universal Tablet Mount

All dimensions = inch (mm)

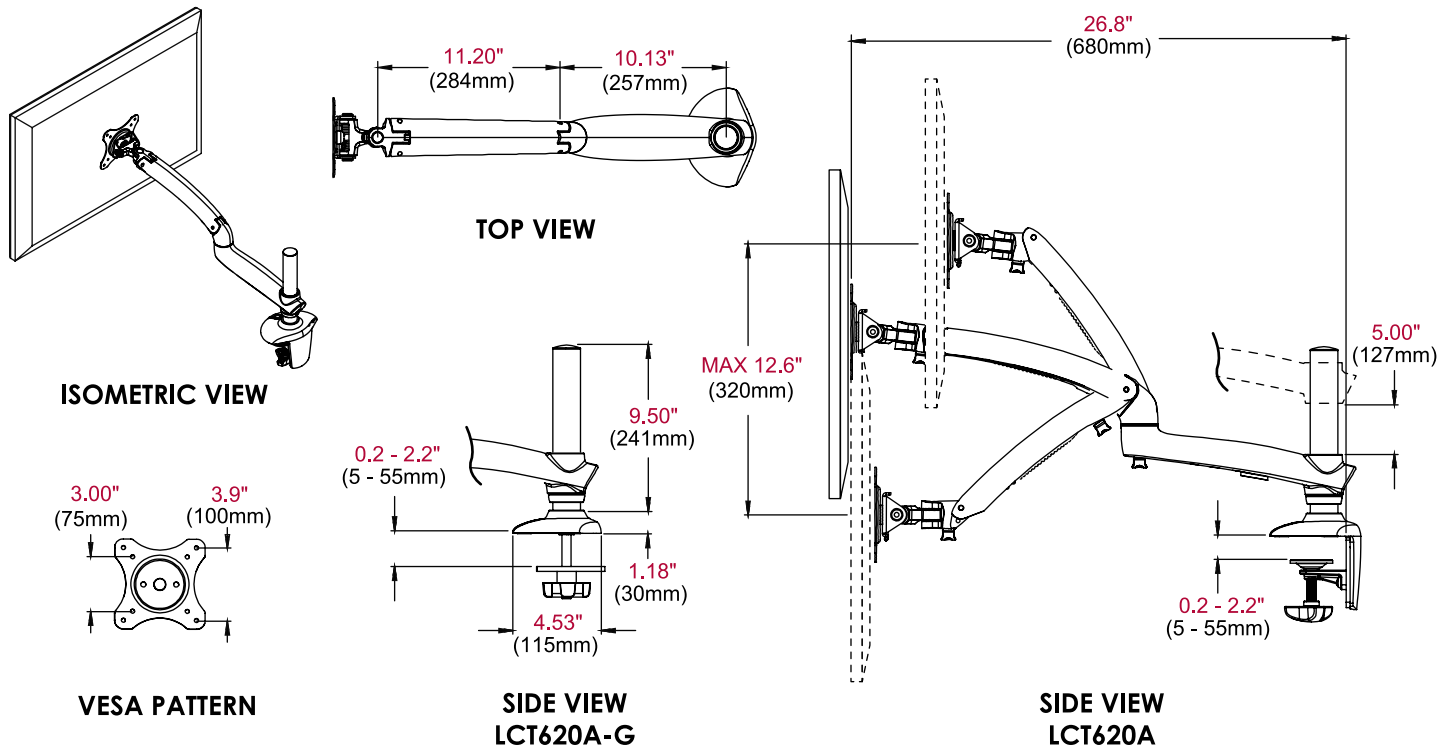

Architect Specifications

The Desktop Monitor Arm Mount shall be a Peerless-AV model LCT620A(-G) and shall be located where indicated on the plans.. Assembly and installation shall be done according to instructions provided by the manufacturer.

Visit peerless-av.com to see the complete line of AV solutions from Peerless-AV, including outdoor displays, wireless, kiosks, digital audio, display mounts, projector mounts, carts/stands, and a full assortment of accessories.



205 Westwood Ave, Long Branch, NJ 07740
Phone: 866-94 BOARDS (26273) / (732)-222-1511
Fax: (732)-222-7088 | E-mail: sales@touchboards.com

LIT-0752 rev.5