

LCT620AD LCT620AD-G



Monitor size
up to 29"



Max load
8.4 to 17.8lb
(3.8 to 8.1kg)

Dual Monitor Desktop Arm Mount

FOR UP TO 29" MONITORS

The LCT620AD and LCT620AD-G Desktop Monitor Mounts feature two attractive height adjustable articulating arms that provide perfect ergonomics with optimum monitor positioning for virtually all users. Choose between a clamp-on or grommet mounting base for limitless mounting options on any desktop or countertop surface between ½" to 2" (12 to 55mm) thick.

Peerless-AV's desktop monitor mounts offer flexible monitor positioning, so the proper viewing angle can be found for all users.



Additional Features

- ✓ Articulating arms allow monitors to be adjusted to the perfect ergonomic position to help reduce eye, back and neck strain
- ✓ Accommodates different monitor weights ranging from 8.4 to 17.8lb (3.8 to 8.1kg)
- ✓ Smooth and effortless arm movement provided by bushings at all pivot points
- ✓ Compatible with VESA® 75 x 75mm and 100 x 100mm mounting patterns
- ✓ Monitors can be positioned anywhere from 2.00" to 20.50" (50 to 502mm) above the desktop surface measured at the center of the adaptor
- ✓ Both style mounting bases accommodate a desktop or counter thickness of 0.2" to 2.2" (5-55mm) thick
- ✓ Expertly finished polished aluminum arm and black base with chrome pole
- ✓ Integrated cable management provides clean, professional installation finish

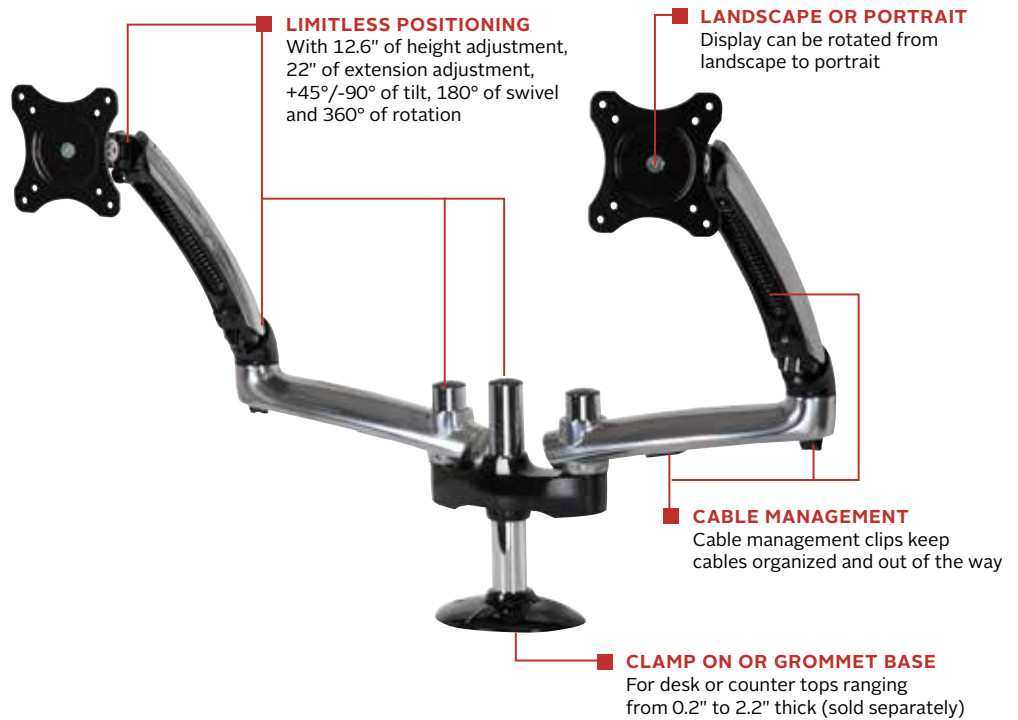

LCT620AD-G's Grommet base works with through holes in the desk or counter top



LCT620AD's Clamp on base easily clamps to edge desk or counter top



Cable management keeps a clean appearance



Model Numbers

WARRANTY: Limited 5-year

LCT620AD	Clamp-on Base Dual Monitor Desktop Arm Mount for up to 29" Monitors
LCT620AD-G	Grommet Base Dual Monitor Desktop Arm Mount for up to 29" Monitors

Product Specifications

	DIMENSIONS (W X H X D)	PRODUCT WEIGHT	LOAD CAPACITY	FINISH	AVAILABLE COLORS
LCT620AD LCT620AD-G	(See Drawing)	19.80lb (9kg)	8.4 to 17.8lb (3.8 to 8.1kg) per arm	High Gloss	Polished Aluminum with Black base and accents

Package Specifications

	PACKAGE SIZE (W x H x D)	PACKAGE SHIP WEIGHT	PACKAGE UPC CODE	PACKAGE CONTENTS	UNITS IN PACKAGE
LCT620AD LCT620AD-G	18.07" x 10.63" x 16.26" (459 x 270 x 413mm)	20.90lb (9.5kg)	735029279877 735029304012	Base with Pole, 2 Arms w/adaptors, Dual arm mount, Hardware & Mounting instructions	1

Accessories

ACC328:	Laptop Tray
ACC450:	VESA® 200 x 200mm Accessory Adaptor Plate
ACC918:	Security Fasteners
PTM200:	Universal Tablet Mount

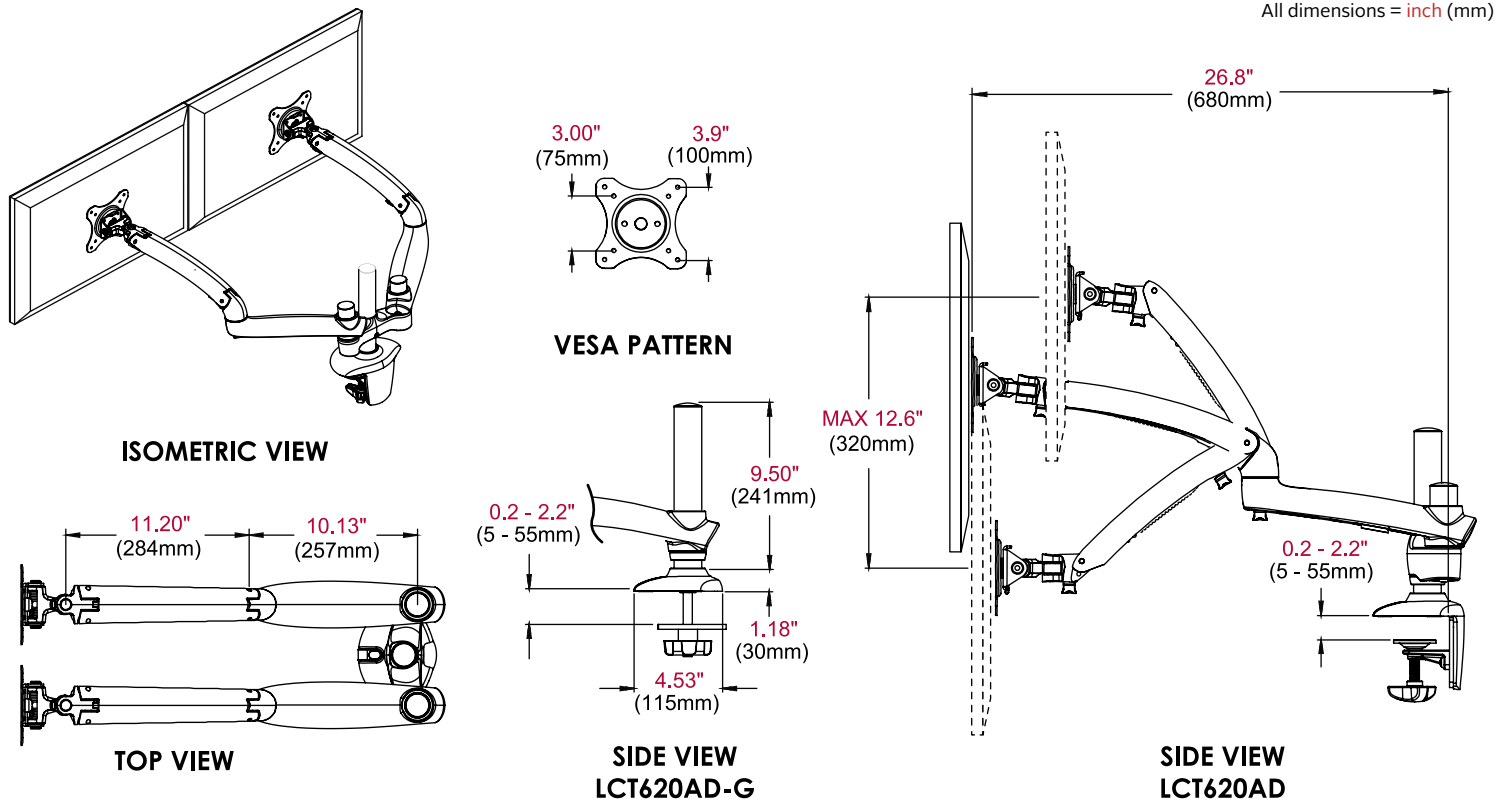

Architect Specifications

The Dual Monitor Desktop Arm Mount shall be a Peerless-AV model LCT620AD(-G) and shall be located where indicated on the plans. Assembly and installation shall be done according to instructions provided by the manufacturer.

Visit peerless-av.com to see the complete line of AV solutions from Peerless-AV, including outdoor displays, wireless, kiosks, digital audio, display mounts, projector mounts, carts/stands, and a full assortment of accessories.

Touchboards peerless-AV®

205 Westwood Ave, Long Branch, NJ 07740
 Phone: 866-94 BOARDS (26273) / (732)-222-1511
 Fax: (732)-222-7088 | E-mail: sales@touchboards.com

LIT-0753 rev.5