

LCW620A

# Monitor Wall Arm w/ Extension for up to 30" Monitors

The LCW620A is a single monitor mount with a flexible articulating arm. Installation is quick and easy and allows positioning of the display for greater productivity. Instantly set the height of the monitor into a comfortable viewing position. A quick release mechanism instantly secures the monitor. Raise or lower the monitor, extend out, tilt forward and back, pan and rotate for portrait and landscape viewing.



Display size: up to 30"



Max load: 15lb (7kg)

## FEATURES

- Arm extends and adjusts for perfect positioning and ergonomic comfort to help reduce eye, back and neck strain
- Independent tension adjustment on the arm
- Tilt: +80°/-20°  
Pan/Swivel: 180°  
Rotate: 360°
- Portrait or landscape without removing the monitor
- Compatible with VESA® 75 and 100mm
- Can be used in laptop configuration with ACC329

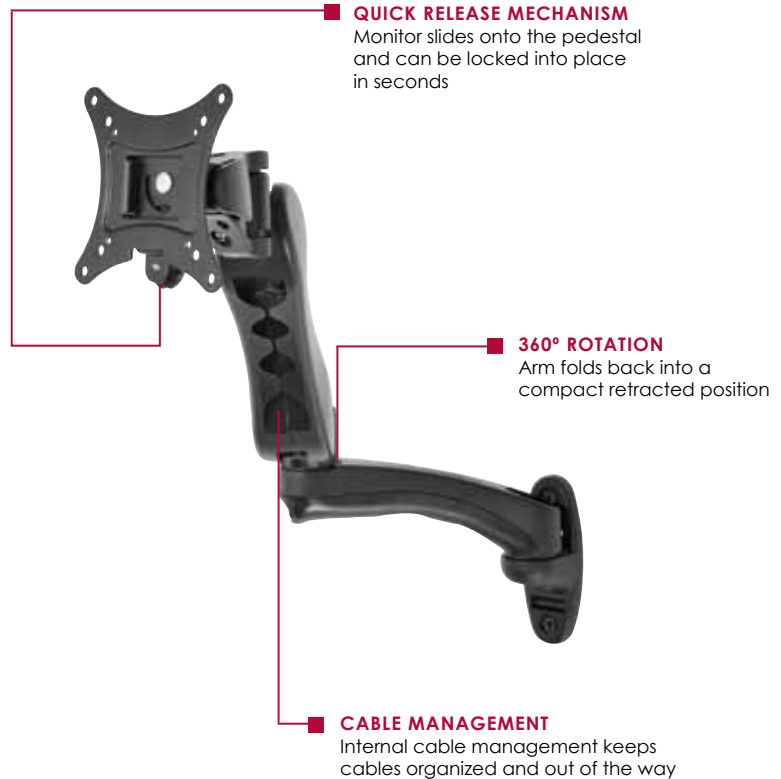

Quick release mechanism



Internal cable management



RoHS

# Touchboards

205 Westwood Ave, Long Branch, NJ 07740  
Phone: 866-94 BOARDS (26273) / (732)-222-1511  
Fax: (732)-222-7088 | E-mail: sales@touchboards.com

peerless-AV®

## Model Numbers

**WARRANTY:** Limited 5-year

**LCW620A** Monitor Wall Arm for up to 30" Monitors

## Product Specifications

	DIMENSIONS (W x H x D)	PRODUCT WEIGHT	LOAD CAPACITY	FINISH	AVAILABLE COLORS
<b>LCW620A</b>	4.50" x 3.94" x 24.76" (114 x 100 x 629mm)	4.5lb (2.0kg)	15.0lb (7kg)	Powder coat	Black

## Package Specifications

	PACKAGE SIZE (L x W x H)	PACKAGE SHIP WEIGHT	PACKAGE UPC CODE	PACKAGE CONTENTS	UNITS IN PACKAGE
<b>LCW620A</b>	4.00" x 10.62" x 19.62" (102 x 270 x 498mm)	6.9lb (3.1kg)	735029279914	Wall plate, arm, display mount, mounting hardware	1

## Accessories

**ACC918:** Security Fasteners  
**ACC329:** Laptop Cooling Tray

All dimensions = inch (mm)

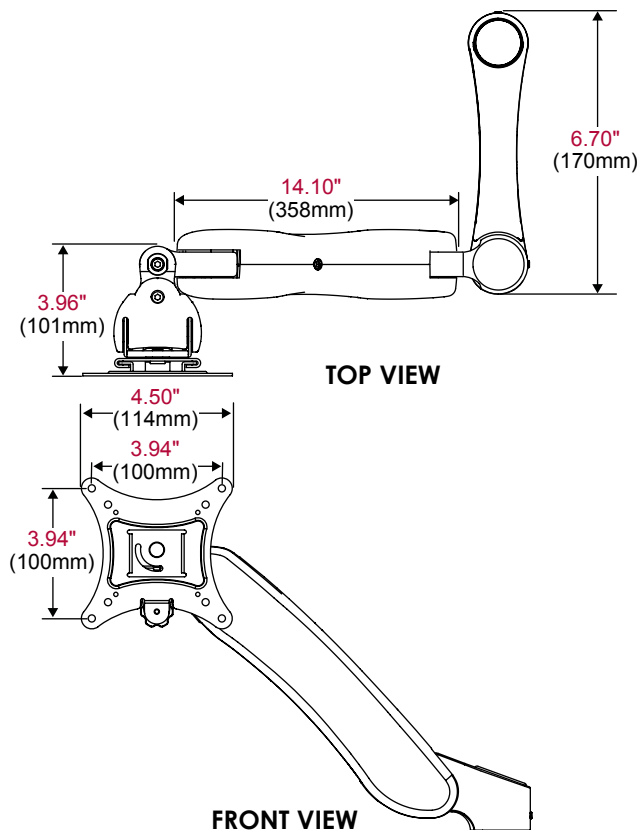

205 Westwood Ave, Long Branch, NJ 07740  
 Phone: 866-94 BOARDS (26273) / (732)-222-1511  
 Fax: (732)-222-7088 | E-mail: sales@touchboards.com

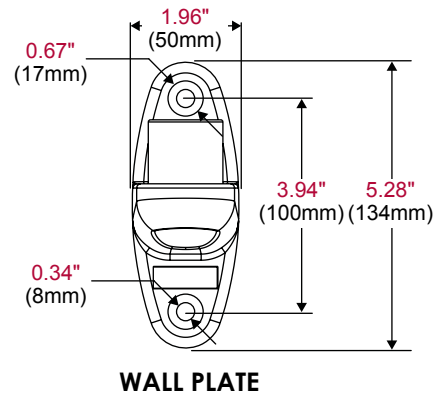

## ARCHITECTS SPECIFICATIONS

The 620-Series Wall Mount shall be a Peerless-AV model LCW620A and shall be located where indicated on the plans. Assembly and installation shall be done according to instructions provided by the manufacturer.

Peerless Industries, Inc. ■ 2300 White Oak Circle ■ Aurora, IL 60502 ■ (800) 865-2112 ■ (630) 375-5100 ■ Fax: (800) 359-6500 ■ peerless-av.com

Visit peerless-av.com to see the complete line of AV solutions from Peerless-AV, including flat panel mounts, projector mounts, carts/stands, furniture, cables, screen cleaners and a full assortment of accessories.