

Panasonic
ideas for life

Touchboards

205 Westwood Ave, Long Branch, NJ 07740
Phone: 866-94 BOARDS (26273) / (732)-222-1511
Fax: (732)-222-7088 | E-mail: sales@touchboards.com

Installation and Assembly:
Mount for Panasonic TH-103PF12U, TH-103PH9UK, TH-103VX200U and TH-103PB1U

Model: PANA-103MTV

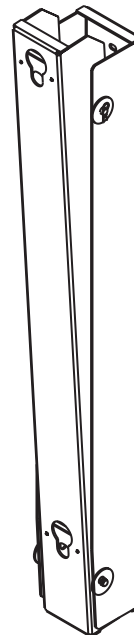
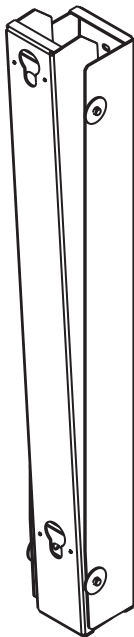

Max Load Capacity: 500 lb (227 kg)

Note: Read entire instruction sheet before you start installation and assembly.

⚠ WARNING

- Do not begin to install your Panasonic product until you have read and understood the instructions and warnings contained in this Installation Sheet. If you have any questions regarding any of the instructions or warnings, please call Panasonic Customer Support.
- This product should only be installed by a qualified professional.
- Make sure that the supporting surface will safely support the combined load of the equipment and all attached hardware and components.
- Never exceed the Maximum Load Capacity of 500 lb (227 kg).
- Always use an assistant or mechanical lifting equipment to safely lift and position equipment.
- Tighten screws firmly, but do not overtighten. Overtightening can damage the items, greatly reducing their holding power.

Parts List		
Description	Qty.	Part #
A wall plate	2	201-1201
B tilt plate	2	201-1203
C lock tab	4	201-1204
D washer	8	540-1005
E clevis pin	4	560-2115
F cotter pin	4	560-2157
G M5 x 6 mm phillips screw	8	520-9504
H nylock nut	8	530-9412
I SAE washer	8	540-9448
J M10 x 20 mm socket screw	8	5S1-M10-A20

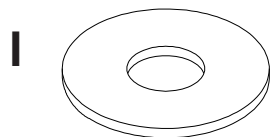
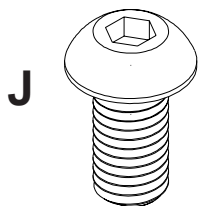
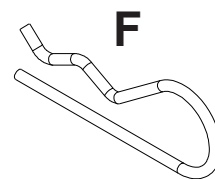
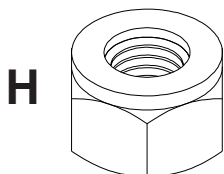
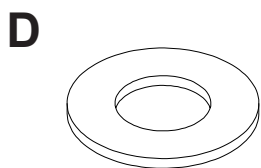
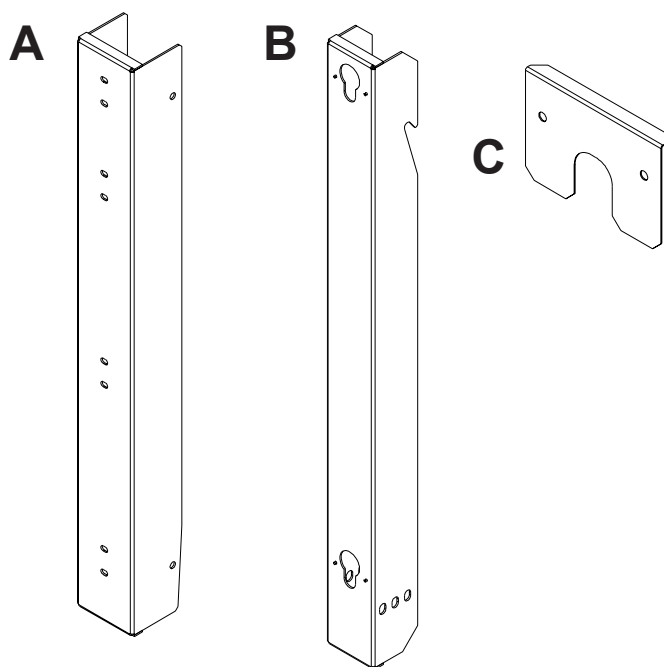

For customer care call (800) 865-2112.

Installation to Wall

⚠ WARNING

- Installer must verify that the supporting surface will safely support four times the combined weight of all attached equipment and hardware.
- Only meant for surface mounting to the desired wall, recessed mounting or any other application please contact customer care.

1 Attach wall plates (A) to supporting surface. Distance between centers of wall plates (A) must be 59.5" (1511 mm) and wall plates (A) must be level with one another.

M10 x 20 mm socket screws (J), nylock nuts (H), and SAE washers (I) may be used to attach wall plates to wall.

Note: If using custom fasteners to attach wall plates to wall be sure that fasteners can support the combined weight of all attached equipment and hardware.

CAUTION

- If wall mounts are not level and square, mount will not function properly.
- If using custom fasteners to attach wall plates to wall be sure that fasteners can support the combined weight of all attached equipment and hardware.

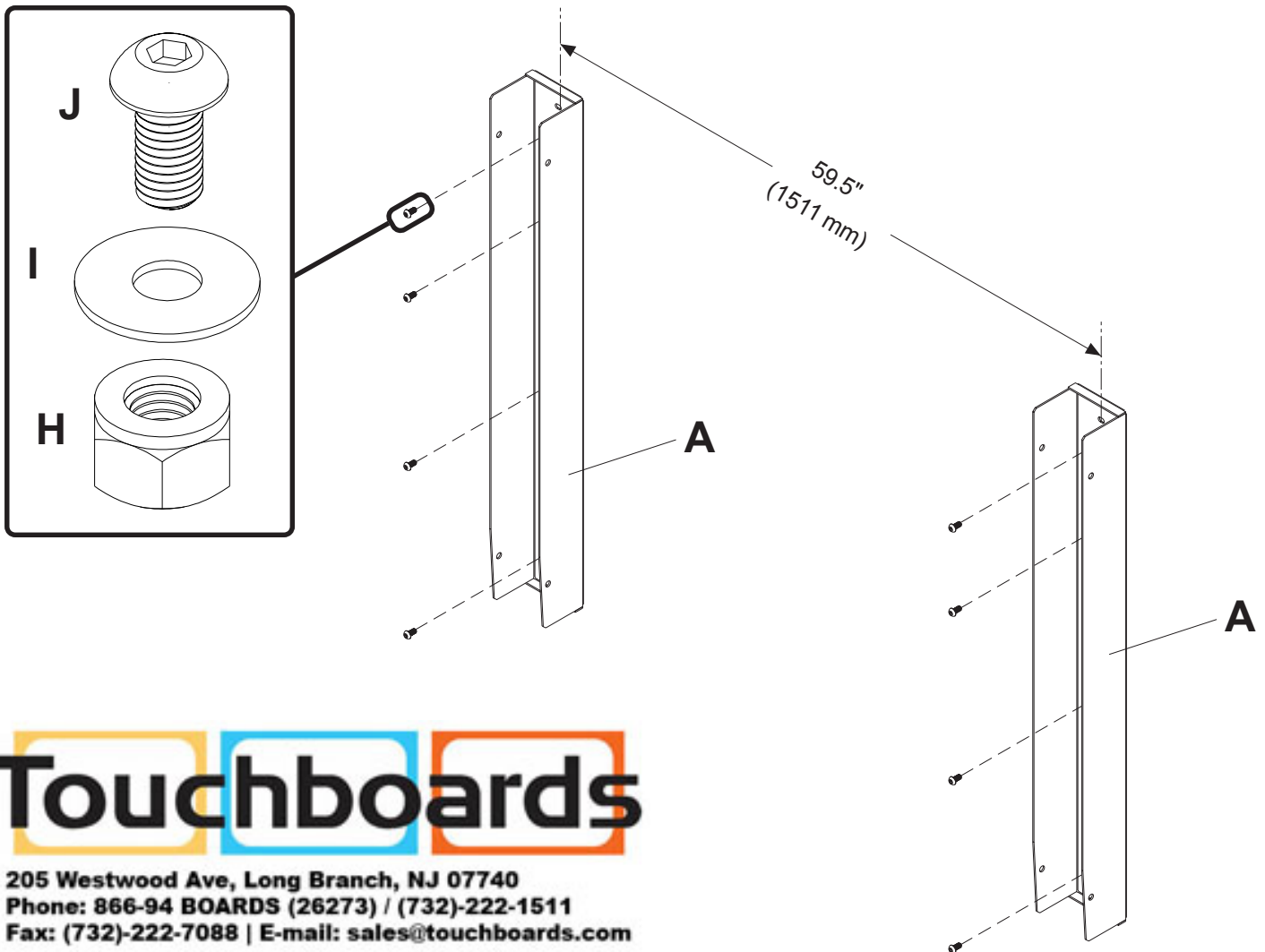

Touchboards

205 Westwood Ave, Long Branch, NJ 07740
Phone: 866-94 BOARDS (26273) / (732)-222-1511
Fax: (732)-222-7088 | E-mail: sales@touchboards.com

- 2** Slide keyhole slots of tilt plates (**B**) onto spacers provided with screen. Secure tilt plates (**B**) to screen by using eight M5 x 6 mm screws (**G**) to attach four locking tabs (**C**) to keyhole slots as shown in Detail 1.

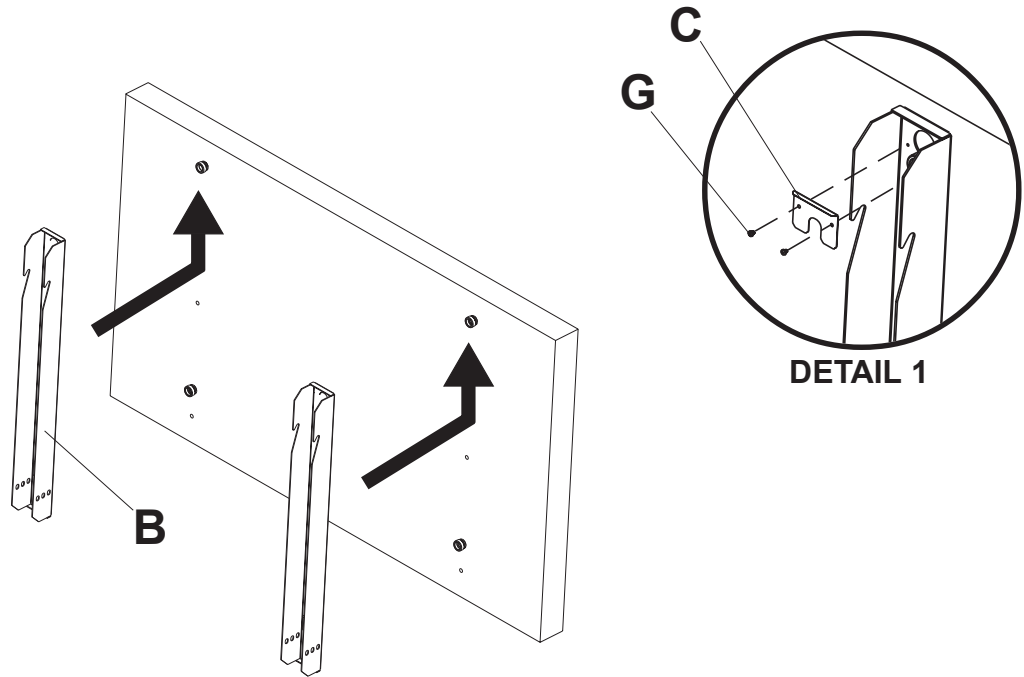

- 3** Attach clevis pin to wall plates (**A**) using two washers (**D**). Secure clevis pin (**E**) with cotter pin (**F**) as show below. Attach tilt plates (**B**) to wall plates (**A**) by sliding tilt plate (**B**) onto clevis pin (**E**) per set of brackets.

Note: Screen not shown for clarity.

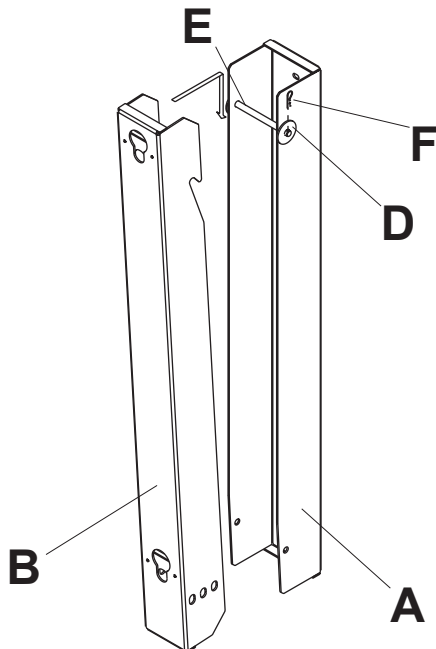

- 4** Set tilt plate (**B**) to desired tilt shown in detail 2. Secure with one clevis pin (**E**), two washers (**D**), and one cotter pin (**F**) per set of brackets.

