

PE1120(-W)

Projector Enclosure

For use with Peerless-AV® Projector Mounts

Lock in the highest level of projector security with the PE1120. Its solid steel construction provides maximum security and is designed to be easily retrofitted to any projector mount, protecting the projector from theft and physical damage. Its wrap-around design and 'Hook-n-Hang' frame enables easy one-person installation and projector maintenance.



FEATURES

- Secures and protects most projectors
- Interlocking top tray design is ideal for retrofit applications
- Adjustable bars allow for ideal projector lens placement
- Patented security fasteners and security wrench only offered by Peerless
- Padlock ready
- Inside dimensions measure 11" high x 20" wide x 20" deep
- Pipe clamp accommodates 1" NPT to 1.5" NPT schedule 40 pipe
- 'Hook-n-Hang' feature allows hands-free operation during projector installation or maintenance

** Projector mount sold separately

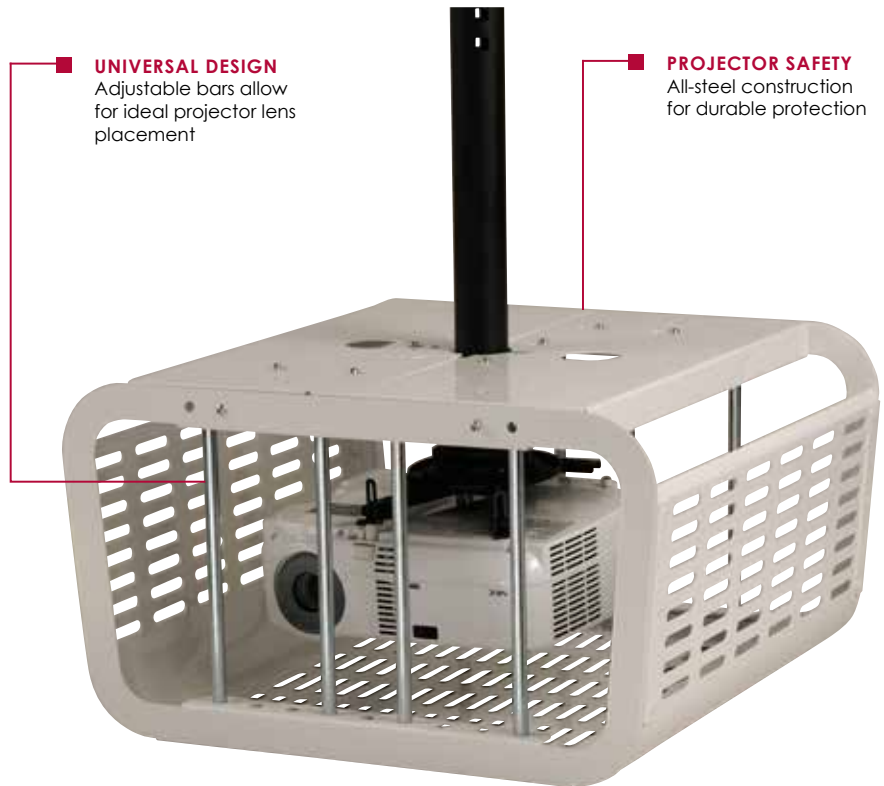

UNIVERSAL DESIGN
Adjustable bars allow for ideal projector lens placement

PROJECTOR SAFETY
All-steel construction for durable protection



Maintenance Free
Hook-n-Hang Feature



Touchboards

205 Westwood Ave, Long Branch, NJ 07740
Phone: 866-94 BOARDS (26273) / (732)-222-1511
Fax: (732)-222-7088 | E-mail: sales@touchboards.com

peerless-AV®

PE1120(-W)	Projector Enclosure for use with Peerless-AV® Projector Mounts
-------------------	--

Product Specifications

	DIMENSIONS (W x H x D) with adapter plate	PRODUCT WEIGHT	LOAD CAPACITY	FINISH	AVAILABLE COLORS
PE1120(-W)	22.41" x 12.57" x 20.53" (569 x 319 x 521 mm)	35lb (15kg)	N/A	Powder Coat	PE1120: Black PE1120-W: White

Package Specifications

	PACKAGE SIZE (W x H x D)	PACKAGE SHIP WEIGHT	PACKAGE UPC CODE	PACKAGE CONTENTS	UNITS IN PACKAGE
PE1120(-W)	23.75" x 16" x 26.75" (603 x 406 x 679 mm)	43.5lb (19.8kg)	PE1120: 735029244202 PE1120-W: 735029244219	Enclosure, pipe clamp, top tray, security fasteners, security bars and assembly instructions	1

Accessories

- PRGS, PRSS, PJF2 models:** Projector Mounts
- AEC, ALU and EXT models:** Extension Columns
- CMJ450/453/455 models:** Suspended Ceiling Accessory

All dimensions = inch (mm)

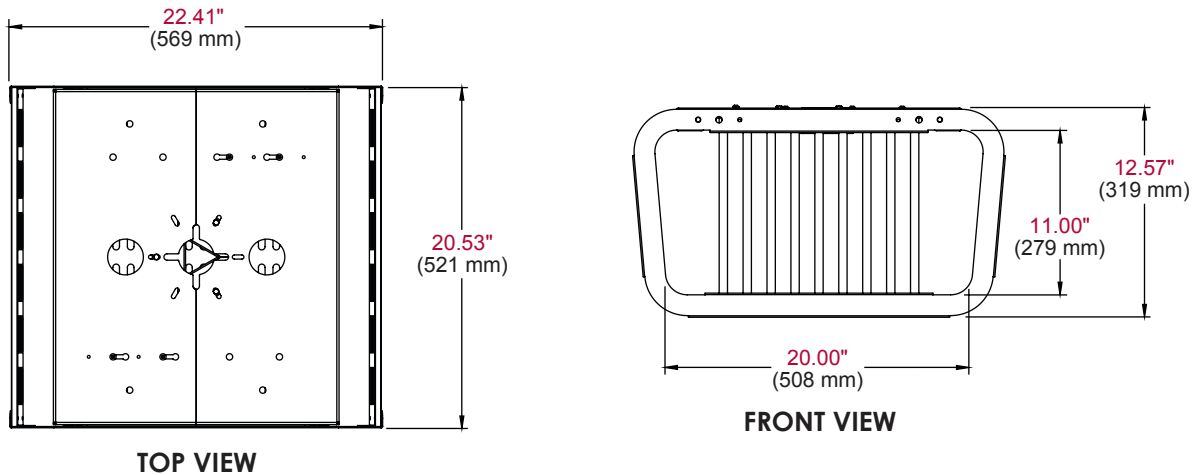

205 Westwood Ave, Long Branch, NJ 07740
 Phone: 866-94 BOARDS (26273) / (732)-222-1511
 Fax: (732)-222-7088 | E-mail: sales@touchboards.com

ARCHITECTS SPECIFICATIONS

The Projector Enclosure shall be a Peerless-AV model PE1120(-W) and shall be located where indicated on the plans. It shall be constructed of steel and finished in black or white fused epoxy. Assembly and installation shall be done according to instructions provided by the manufacturer.

Peerless Industries, Inc. ■ 2300 White Oak Circle ■ Aurora, IL 60502 ■ (800) 865-2112 ■ (630) 375-5100 ■ Fax: (800) 359-6500 ■ peerless-av.com

Visit peerless-av.com to see the complete line of AV solutions from Peerless-AV, including flat panel mounts, projector mounts, carts/stands, furniture, cables, screen cleaners and a full assortment of accessories.