

Short Throw Projector Mount

For ultra-short throw projectors up to 50lb (22kg)

The Peerless-AV® Short Throw Projector Mounts provide installation flexibility for single stud or double stud applications. The universal telescoping arm is easily adjustable to accommodate various short throw projector distance requirements and the PSTK series also provides up to 6" (152mm) of lateral adjustment for perfect projector placement. Complementary to the universal design of the short throw projector arm, this comprehensive package comes with Peerless-AV's Universal Precision Gear Projector Mount that makes image alignment as simple as a turn of a knob. To tie it all together, the internal cable management system provides a clean clutter-free solution.



Max load: 50lb (22kg)

PSTA-028(-W)
 PSTK-028(-W)



FEATURES

- Sliding carriage design allows projector mount to glide into place at any location on the short throw arm
- Access slots allow for all internal cable management
- Pre-installed security screws lock down short throw arm and prevent tampering
- Includes PRGS-UNV Projector Mount with precision gear alignment and adjustment knobs to control tilt and roll alignment
- Specifications:
 - Pitch: +15°/-20°
 - Roll: ±5°
 - Swivel: ±360° (during installation)

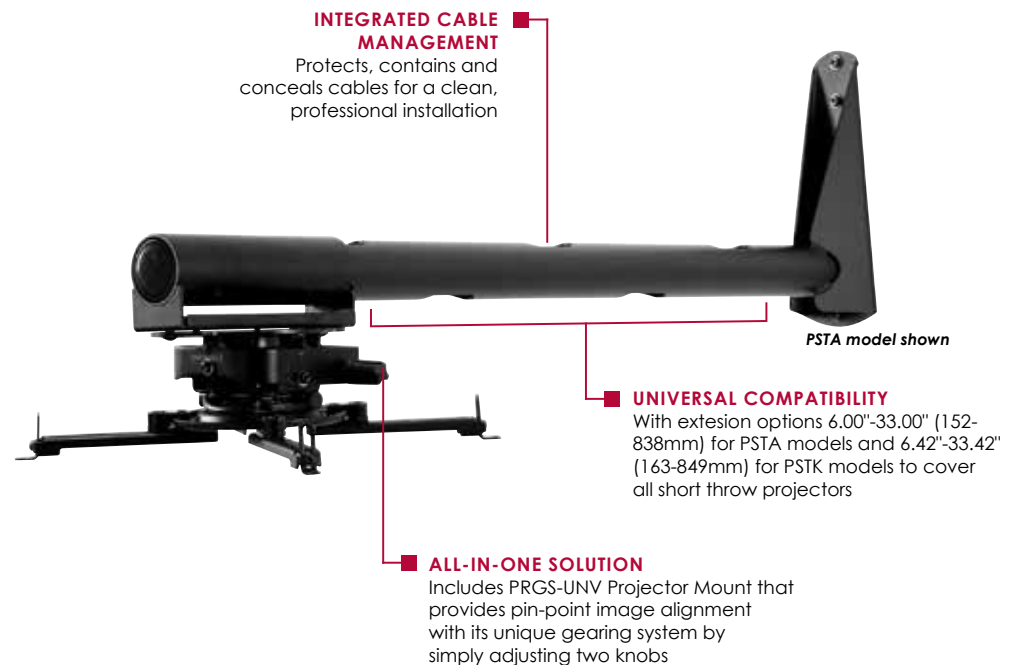

The PSTK model's double stud wall plate allows for placement on walls where stud location may not be in the optimum location

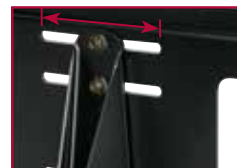

Post-installation lateral adjustment for optimal arm alignment, with PSTK model



Cable management access holes provide internal cable management

Model Numbers

WARRANTY: Limited 5-year

PSTA-028(-W)	Short Throw Projector Mount (Includes PRGS-UNV) for projectors up to 50lb (22kg)
PSTK-028(-W)	Short Throw Projector Mount (Includes PRGS-UNV and wall plate) for projectors up to 50lb (22kg)

Product Specifications

	DIMENSIONS (W x H x D)	PRODUCT WEIGHT	LOAD CAPACITY	FINISH	AVAILABLE COLORS
PSTA-028(-W)	5.59" x 12.73" x 36.20" (142 x 323 x 919mm)	11lb (4kg)	50lb (22kg)	Powder Coat	PSTA-028 PSTK-028 Black
PSTK-028(-W)	18.50" x 13.79" x 36.61" (470 x 350 x 930mm)	16lb (7kg)			PSTA-028-W PSTK-028-W White

Package Specifications

	PACKAGE SIZE (W x H x D)	PACKAGE SHIP WEIGHT	PACKAGE UPC CODE	PACKAGE CONTENTS	UNITS IN PACKAGE
PSTA-028	17.13" x 4.75" x 45.75" (435 x 120 x 1162mm)	12.2lb (5.55kg)	735029262848	Short throw arm, PRGS-UNV, installation hardware, assembly instructions. PSTK Model also includes double stud wall plate.	1
PSTK-028		16.3lb (7.39kg)	735029263043		
PSTA-028-W		12.2lb (5.55kg)	735029262855		
PSTK-028-W		16.3lb (7.39kg)	735029263050		

Accessories

WBK100	Double Stud Wall Plate	ACC020	Projector Security Cable	ACC215/415/615	Metal Stud Fastener Kit
---------------	------------------------	---------------	--------------------------	-----------------------	-------------------------

All dimensions = inch (mm)

PSTA

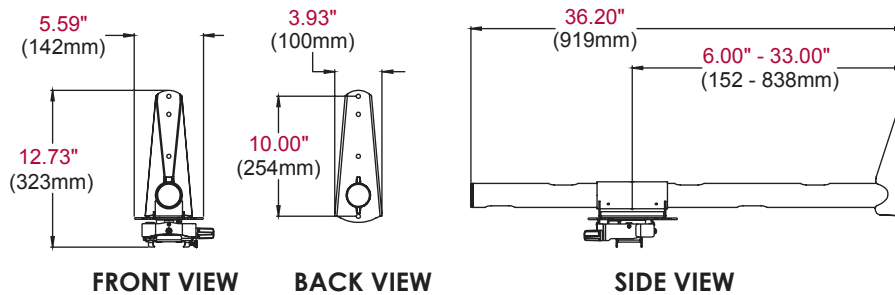

PSTK

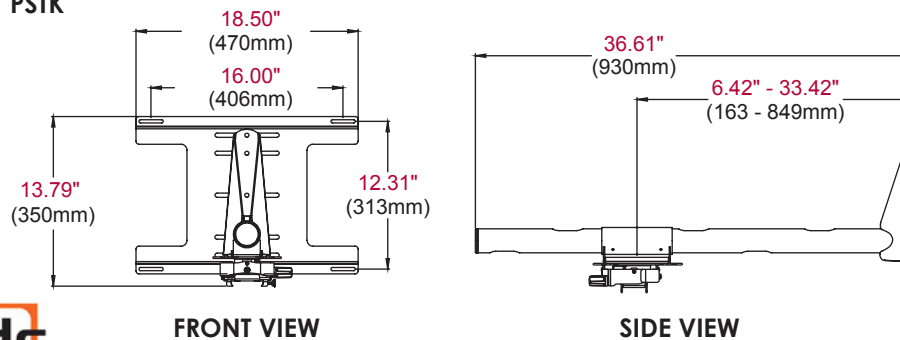

205 Westwood Ave, Long Branch, NJ 07740
Phone: 866-94 BOARDS (26273) / (732)-222-1511
Fax: (732)-222-7088 | E-mail: sales@touchboards.com

ARCHITECTS SPECIFICATIONS

The Short Throw Projector Mount shall be a Peerless-AV model PSTA-028(-W)/ PSTK-028(-W) and shall be located where indicated on the plans. It shall be constructed of heavy gauge cold rolled steel and feature scratch resistant white and black powder coat finish. Assembly and installation shall be done according to instructions provided by the manufacturer.

Peerless Industries, Inc. ■ 2300 White Oak Circle ■ Aurora, IL 60502 ■ (800) 865-2112 ■ (630) 375-5100 ■ Fax: (800) 359-6500 ■ peerless-av.com

Visit peerless-av.com to see the complete line of AV solutions from Peerless-AV, including flat panel mounts, projector mounts, carts/stands, furniture, cables, screen cleaners and a full assortment of accessories.