

SF670(P) SF670-AB/AW

SMARTMOUNT. Universal Flat Wall Mount for 46" to 90" Displays

The sturdy SF670 wall plate holds displays weighing up to 250lb while featuring junction box access ports and horizontal display adjustment up to 12" for ideal display positioning. Its easy-glide brackets enable quick display-to-mount attachment with a simple hook-on design. Delivering an ultra-slim profile, this mount is the essential element for low-profile installations of extra-large displays.



Display size: 46"-90"



Max load: 250lb (113kg)

FEATURES

- Fits displays with mounting hole patterns up to 908 x 503mm (35.75" W x 19.79" H)
- Low-profile design holds display only 1.73" (44mm) from the wall for a clean application
- Easy-glide bracket design ensures display is securely attached to wall plate
- Horizontal display adjustment up to 12" (304mm)
- Mounts to wood studs, concrete, cinder block or metal studs (metal stud accessory required)
- Includes fastener pack with all necessary mounting and display attachment hardware
- UL listed
- Agion® antimicrobial* finish assists in controlling the spread of infections with SF670-AB/AW models

VIEWING FLEXIBILITY

Horizontal display adjustment up to 12" (304mm) for centering screen on wall



EASY INSTALLATION

Simple hook-on design makes installation safe, quick and easy

OPEN ARCHITECTURE

Wall plate knockouts provide wall access improving cable management options



Low-profile design holds display only 1.73" (44mm) from the wall



*With max load up to 200lb (90kg)

SF670-AB/AW:



Patented. Utility Patent No. 7,722,002; 8,517,322; 8,348,212.

* Antimicrobial protection is limited to the treated article and does not protect a user against disease causing bacteria. Always clean products thoroughly after each use. Visit agion-tech.com for more details.

SF670P	SmartMount® Universal Flat Wall Mount for 46" to 90" Displays - standard models
SF670(-AB/AW)	SmartMount® Universal Flat Wall Mount for 46" to 90" Displays - security models

Product Specifications

	DIMENSIONS (W x H x D)	PRODUCT WEIGHT	LOAD CAPACITY	FINISH	AVAILABLE COLORS
SF670(-AB/AW)(P)	37.75" x 20.63" x 1.73" (959 x 524 x 44mm)	10.07lb (4.9kg)	250lb (113kg)	Matte	SF670(P) Black SF670-AB Antimicrobial* black SF670-AW Antimicrobial* white

* Antimicrobial protection is limited to the treated article and does not protect a user against disease causing bacteria. Always clean products thoroughly after each use. Visit www.agion-tech.com for more details.

Package Specifications

	PACKAGE SIZE (W x H x D)	PACKAGE SHIP WEIGHT	PACKAGE UPC CODE	PACKAGE CONTENTS	UNITS IN PACKAGE
SF670(-AB/AW)(P)	46.8" x 8.6" x 3.9" (1189 x 218 x 99mm)	13.1lb (5.94kg)	SF670: 735029242192 SF670P: 735029242215 SF670-AB: 735029281450 SF670-AW: 735029281464	Wall mount, universal brackets and mounting and display attachment hardware	1

Accessories

- ACC615:** 6-pack Metal Stud Fastener Kit
- ACC309:** Video Conference Shelf

All dimensions = inch (mm)

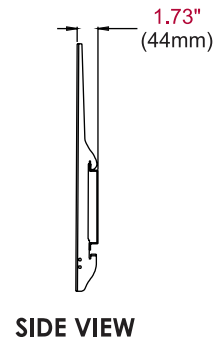
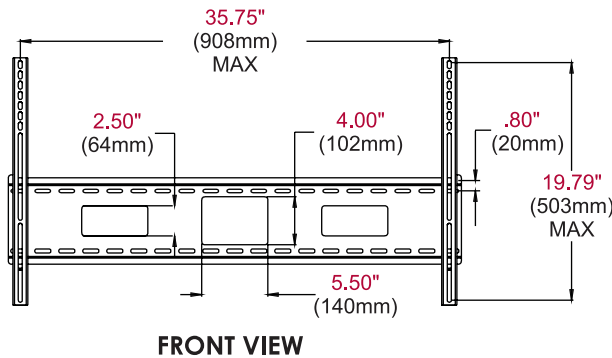
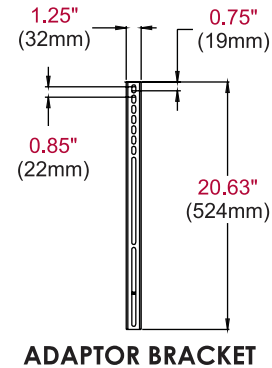
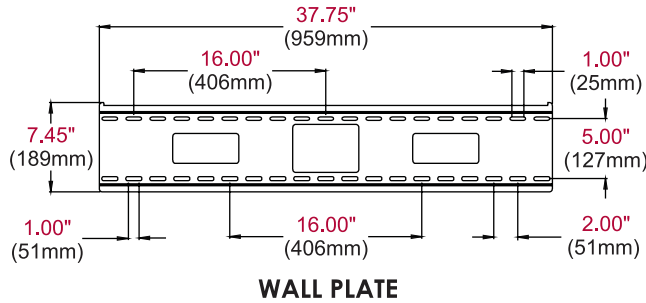

ARCHITECTS SPECIFICATIONS

The Smartmount® Universal Flat Wall Mount shall be a Peerless-AV model SF670(-AB/AW)(P) and shall be located where indicated on the plans. Assembly and installation shall be done according to instructions provided by the manufacturer.