

## SR560M/G SR560M-AB/-AW



Display size  
**32"-75"**



Max load  
**250lb (113.3kg)**  
**150lb (68kg) display**  
**50lb (22.6kg) shelf**

# Flat Panel Floor Cart

FOR 32" TO 75" DISPLAYS

The SR560 Flat Panel Floor Cart offers the most complete mobile solution for any application. This versatile presentation cart allows you to hold meetings with AV support or simply to display information. A full line of accessories enable each cart to be fully tailored to meet your specific requirements.

*Peerless-AV's Flat Panel Floor Cart with continuous vertical adjustment, makes finding the perfect viewing height simply effortless.*



### Additional Features

- ✓ Universal mount fits displays with mounting patterns up to 730 x 405mm (28.75" W x 15.95" H)
- ✓ Continuous vertical adjustment for perfect viewing height
- ✓ Incremental tilt of -2°, 0° and +5° locks in the ideal viewing angle
- ✓ Integrated cable management protects, contains and conceals cables for a clean, professional installation
- ✓ Maneuvers easily on 4" (102mm) swivel casters, two locking
- ✓ Customizable with over a dozen accessories
- ✓ Agion® antimicrobial\* finish assists in controlling the spread of infections with SR560M-AB/AW models

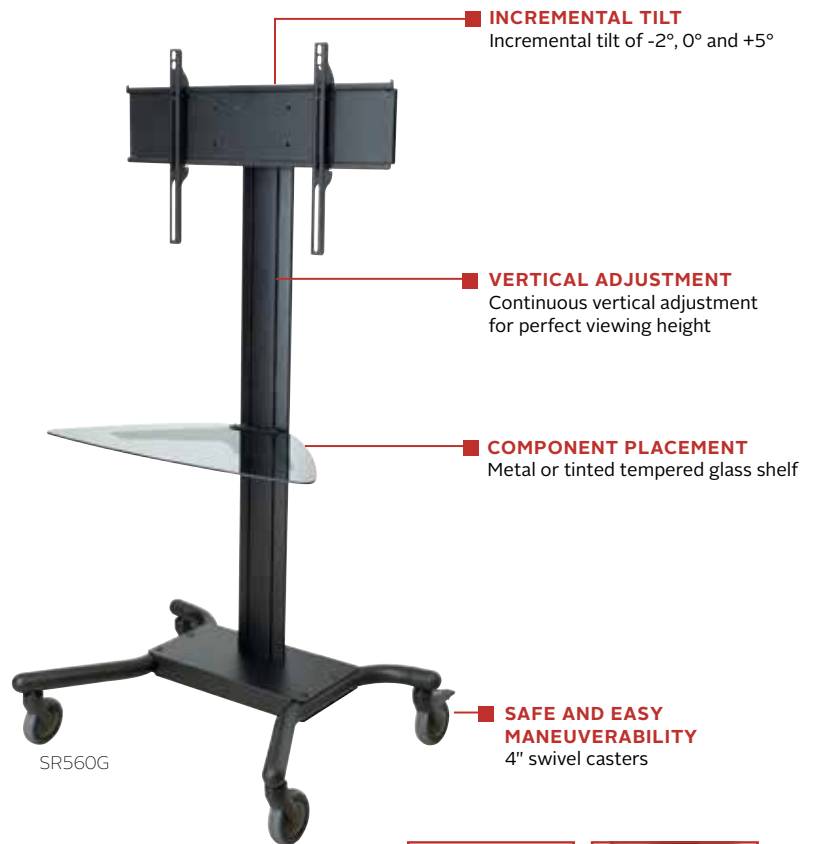

SR560G



SR560M



Integrated cable management

\*Antimicrobial protection is limited to the treated article and does not protect a user against disease causing bacteria. Always clean products thoroughly after each use. Visit agion-tech.com for more details.



SR560M-AB/AW:



SR560M(-AB/AW)/SR560G Flat Panel Floor Cart for 32" to 75" Displays

**Product Specifications**

	DIMENSIONS (W x H x D)	PRODUCT WEIGHT	LOAD CAPACITY	FINISH	AVAILABLE COLORS
SR560M(-AB/AW)	40.00" x 64.15" x 27.45" (1016 x 1630 x 697mm)	76lb (34.4kg)	250lb (113.3kg) total 150lb (68kg) display 50lb (22.6kg) shelf	Powder coat	SR560M/G: Black SR560M-AB: Antimicrobial* black SR560M-AW: Antimicrobial* white
SR560G		74lb (33.6kg)			

\*Antimicrobial protection is limited to the treated article and does not protect a user against disease causing bacteria. Always clean products thoroughly after each use. Visit [agion-tech.com](http://agion-tech.com) for more details.

**Package Specifications**

	PACKAGE SIZE (W x H x D)	PACKAGE SHIP WEIGHT	PACKAGE UPC CODE	PACKAGE CONTENTS	UNITS IN PACKAGE
SR560M(-AB/AW)	57.75" x 19.25" x 7.75" (1467 x 489 x 197mm)	87.3lb (39.5kg)	SR560M: 735029247715 SR560G: 735029247722	Cart, (1) metal or tinted glass shelf, universal adaptor plate, assembly and display attachment hardware	1
SR560G		88.8lb (40.2kg)	SR560M-AB: 735029281771 SR560M-AW: 735029281788		

**Accessories**

- |                               |  |
|-------------------------------|--|
| <b>ACC310:</b> Feet Accessory | <b>ACC318:</b> Tempered Glass Shelf                              |
| <b>ACC313:</b> Metal Shelf    | <b>ACC319:</b> Video Conferencing Shelf                          |
| <b>ACC314:</b> Laptop Arm     | <b>ACC320:</b> Electrical Outlet Strip with Cord Wrap            |
| <b>ACC315:</b> Base Shelf     | <b>RM11 &amp; ACC170:</b> Universal Rotational Mount and Adaptor |
| <b>ACC316:</b> Safety Belf    | <b>DSX750:</b> Media Player Storage                              |

All dimensions = inch (mm)

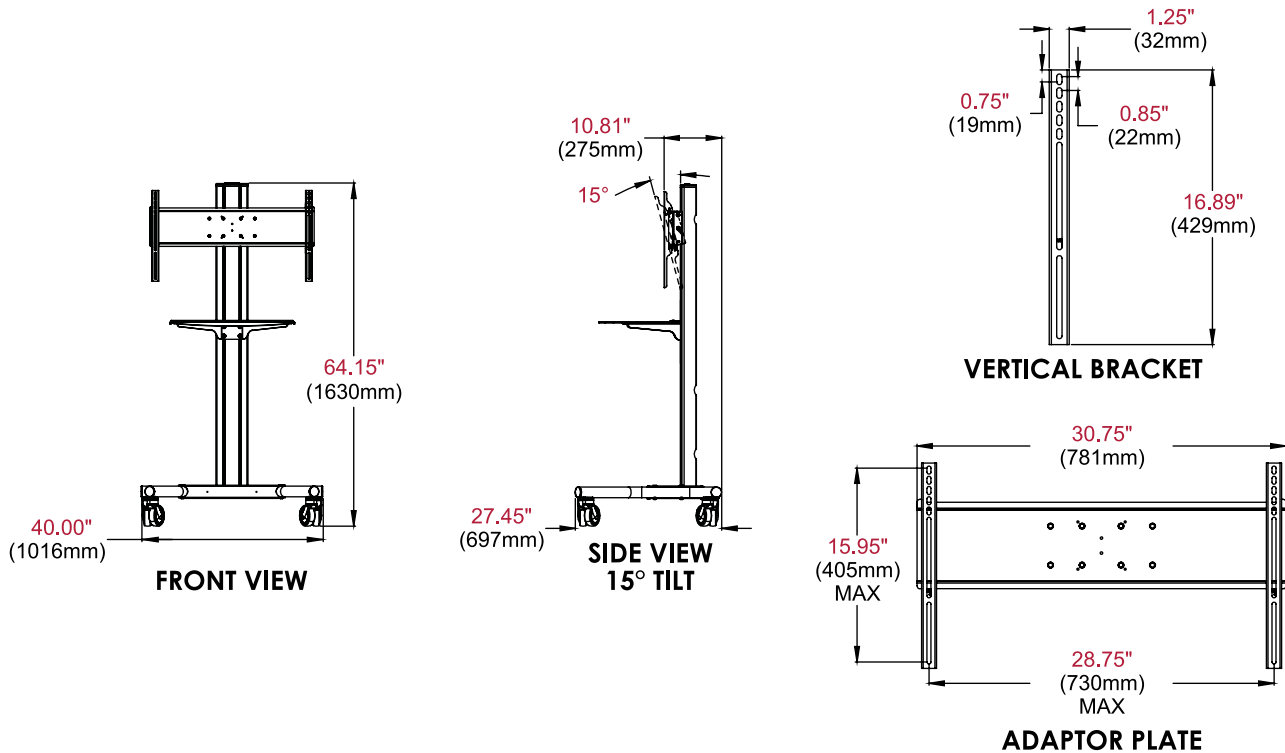

**Architect Specifications**

The Flat Panel Floor Cart shall be a Peerless-AV model SR560M, SR560G or SR560M-AB/-AW and shall be located where indicated on the plans. Assembly and installation shall be done according to instructions provided by the manufacturer.



205 Westwood Ave, Long Branch, NJ 07740  
 Phone: 866-94 BOARDS (26273) / (732)-222-1511  
 Fax: (732)-222-7088 | E-mail: [sales@touchboards.com](mailto:sales@touchboards.com)

