

peerless®

Touchboards

205 Westwood Ave, Long Branch, NJ 07740
Phone: 866-94 BOARDS (26273) / (732)-222-1511
Fax: (732)-222-7088 | E-mail: sales@touchboards.com

Installation and Assembly: Wall Mount with PC Storage

Model: DSX750

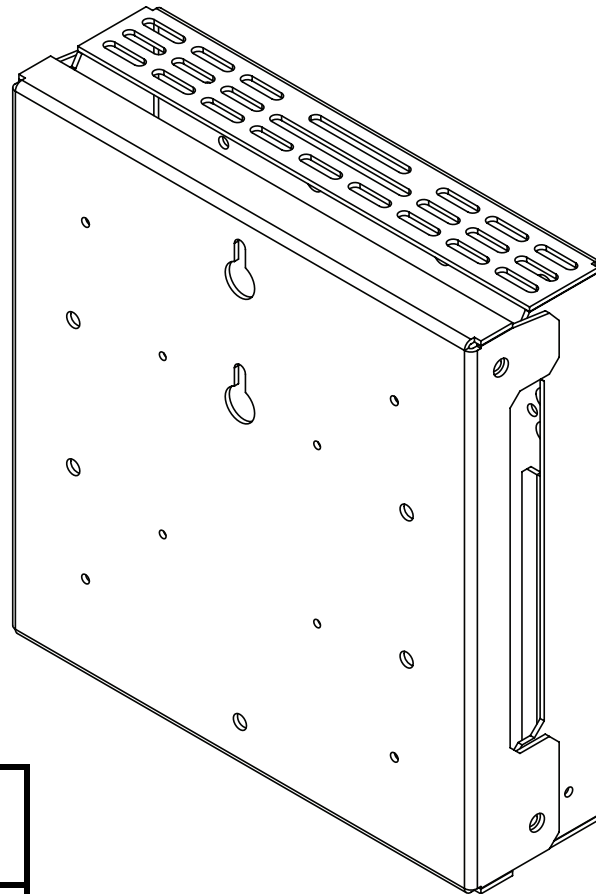

Maximum Load Capacity

Model	Max. Load
Wall Mounted DSX750	200 lb (90 kg)
Wall Mounted DSX750 Using Dedicated Adapter Plate	150 lb (68 kg)
SP850	150 lb (68 kg)
FPS-1000	150 lb (68 kg)
SA745PU	70 lb (32 kg)
SA750PU	130 lb (59 kg)
SA760PU	170 lb (77 kg)
SA770PU	170 lb (77 kg)
SA752PU	80 lb (36 kg)
SA761PU	130 lb (59 kg)
SA763PU	160 lb (73 kg)
SA771PU	160 lb (73 kg)

ISSUED: 04-08-10 SHEET #:125-9110-2 04-16-10

Visit the Peerless Web Site at www.peerlessmounts.com

For customer care call 1-800-865-2112 or 708-865-8870.

Before you begin, make sure all parts shown are included with your product.

Parts may appear slightly different than illustrated.

PARTS LIST			
Description		Qty.	Part #
A	adapter plate	1	201-1724
B	wall plate	1	201-1699
C	rubber feet (pack of four)	1	570-1036
D	M8 x 15mm socket pin screw	4	520-1068
E	M10 x 15 mm penta-pin screw	4	520-9263
F	M10 penta-pin tool	1	520-9260
G	M6 x 12 mm socket pin screw	4	510-1050
H	#10 flat washer	4	540-9400
I	4 mm allen wrench	1	560-9646
J	M6 x 16 mm socket pin screw	4	520-1132
K	#8 flat washers	4	540-1001
L	M5 x 12 mm socket pin screw	4	520-1064
M	cable tie	4	560-9711
N	M4 x 12 mm socket pin serrated washer head screw	4	510-1079
O	#14 x 2.5" hex head wood screw	3	5S1-015-C03
P	concrete anchor	3	590-0320

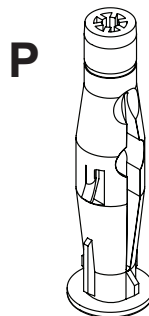
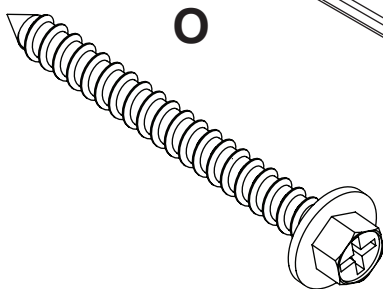
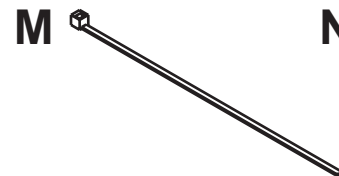
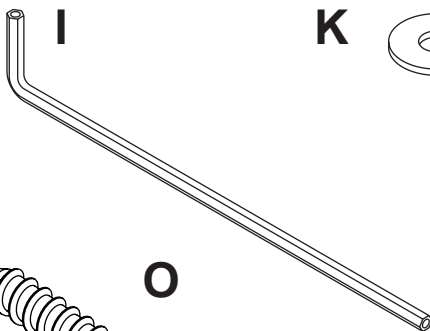
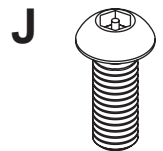
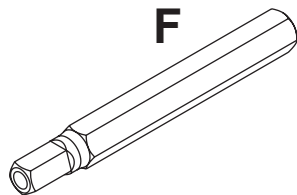
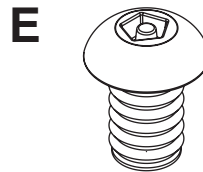
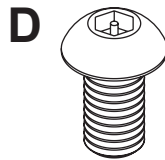
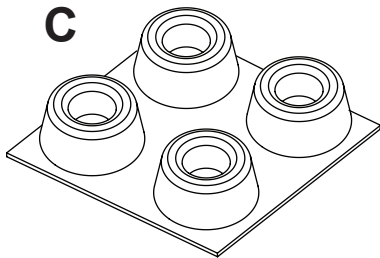
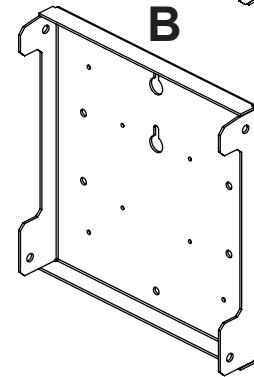
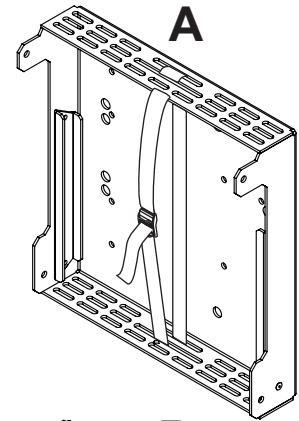

Attaching Wall Plate to dedicated adapter Plates:

- Using the hole pattern shown in detail 1, attach the adapter plate (A) to dedicated adapter plate with four M10 x 15 mm screws (E) as shown in figure 1.1. Tighten screws using M10 penta-pin tool (F). If attaching to articulating mount use M10 x 15 mm screws (supplied with mount).

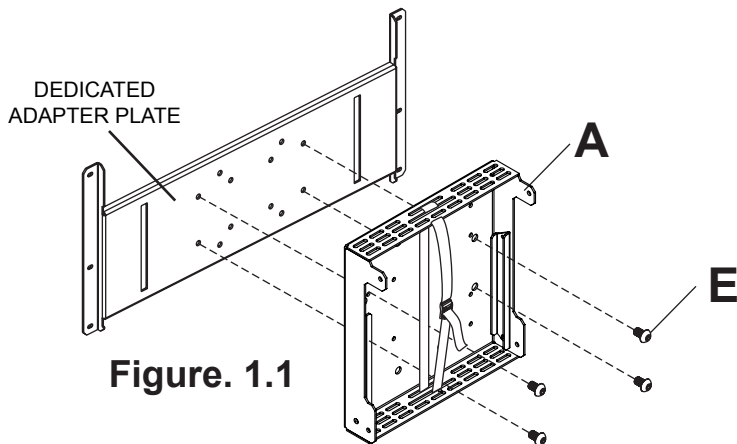

MOUNTING PATTERN FOR DEDICATED ADAPTER PLATES

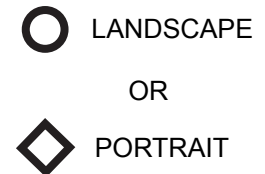
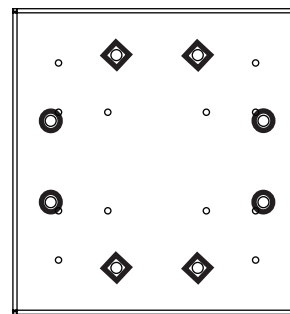

DETAIL 1

Attaching Adapter Plate to Screen Using SP850, FPS-1000

- Attaching adapter plate to screen with VESA hole pattern:

Choose hole pattern and fasteners shown in detail 2 for mounting screen with VESA mounting patterns. Hand thread screws (N, L or G) through washers (K or H) and adapter plate (A) into screen as shown (right). Screw must make at least three full turns into the mounting hole and fit snug into place. Securely tighten screws using 4 mm allen wrench (I).

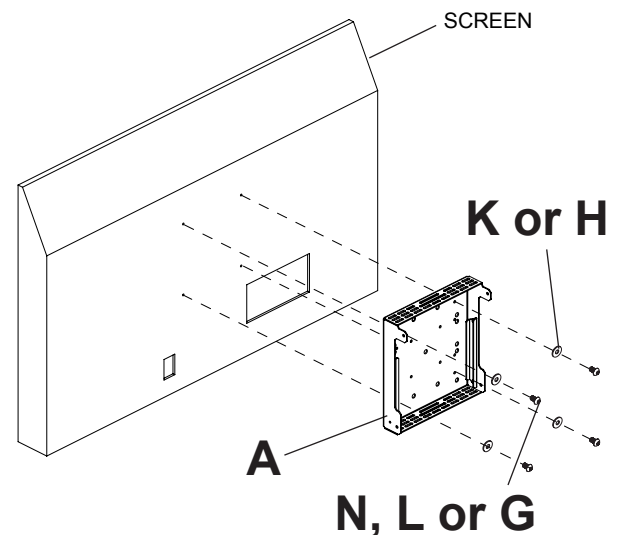

⚠ WARNING

- If screws don't get three complete turns in the screen inserts or if screws bottom out and bracket is still not tightly secured, damage may occur to screen or product may fail.

MOUNTING PATTERNS

VESA® 100 x 100

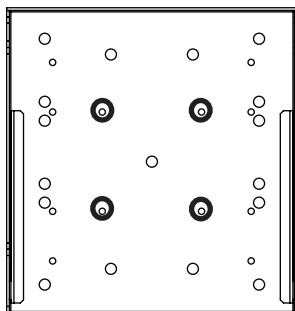

M4 x 12 mm screws (N) with #8 washers (K) or M5 x 12 mm screws (L) with #10 washers (H)

VESA® 200 x 100

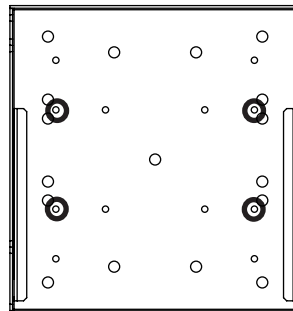

M4 x 12 mm screws (N) with #8 washers (K), M5 x 12 mm screws (L)

VESA® 200 x 200

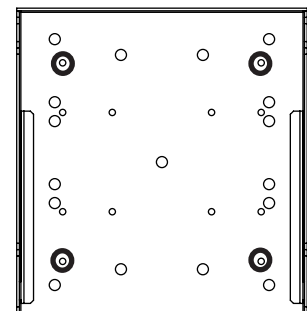

M4 x 12 mm screws (N) with #8 washers (K) or M6 x 12 mm screws (G) with #10 washers (H)

DETAIL 2

Attaching Adapter Plate to Universal Adapter Bracket Using SA745PU, SA750PU, SA760PU, SA770PU

- 1 Secure adapter plate (A) to universal adapter bracket with four M10 x 15 mm screws (supplied with mount) as shown below.

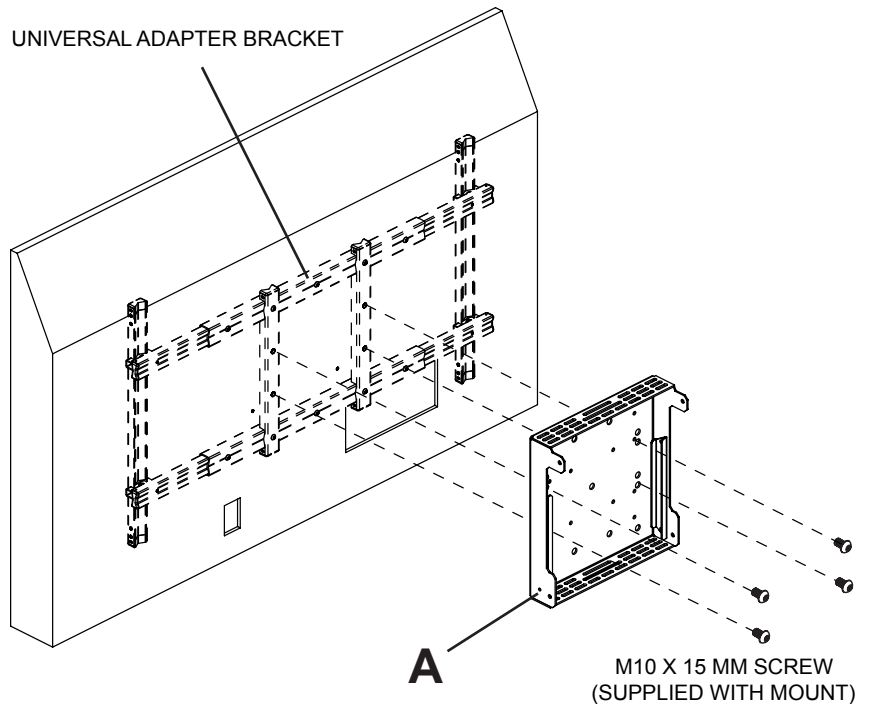
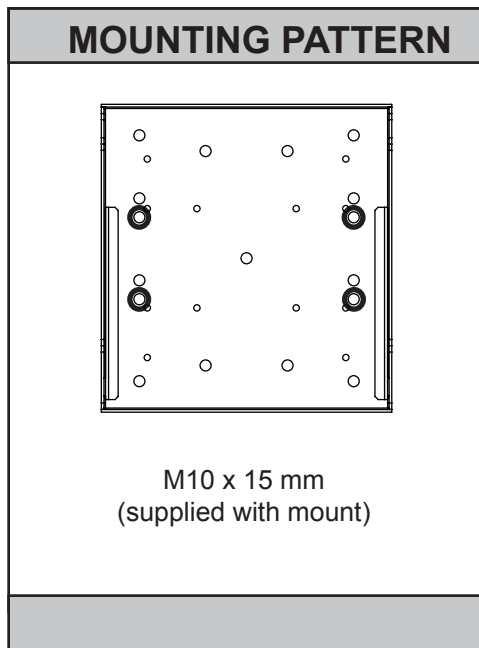

Attaching adapter Plate to Universal Adapter Bracket Using SA752PU, SA761PU, SA763PU, SA771PU (ACC950 Required)

- 1 Secure adapter plate (A) to universal adapter bracket with four M10 x 40 mm screws (supplied with ACC950) as shown in below.

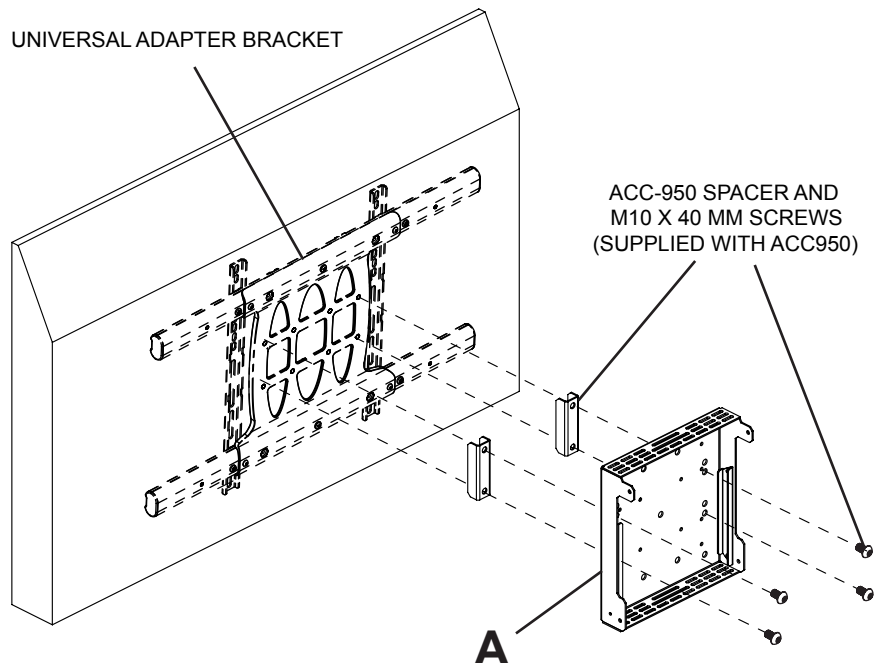
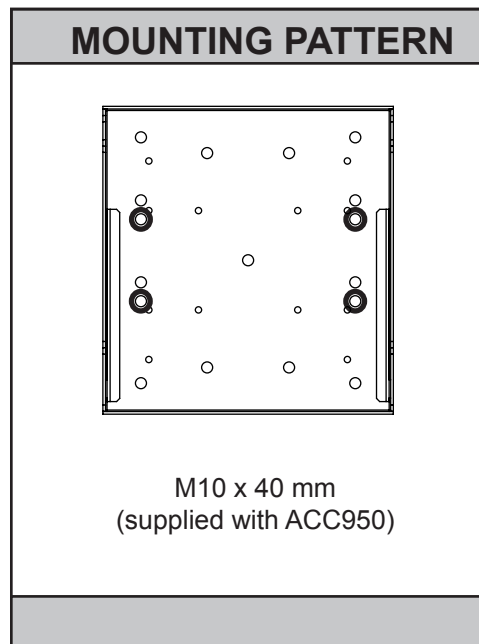

Attach CPU to Tilt Box

- 2** Remove rubber feet from base.
Secure four rubber feet (C) to bottom of CPU as shown below.

NOTE: Safety belt may need to be loosened to attach CPU to adapter plate (A).
Press CPU against adhesive strips on adapter plate (A) and tightly secure safety belt against CPU.

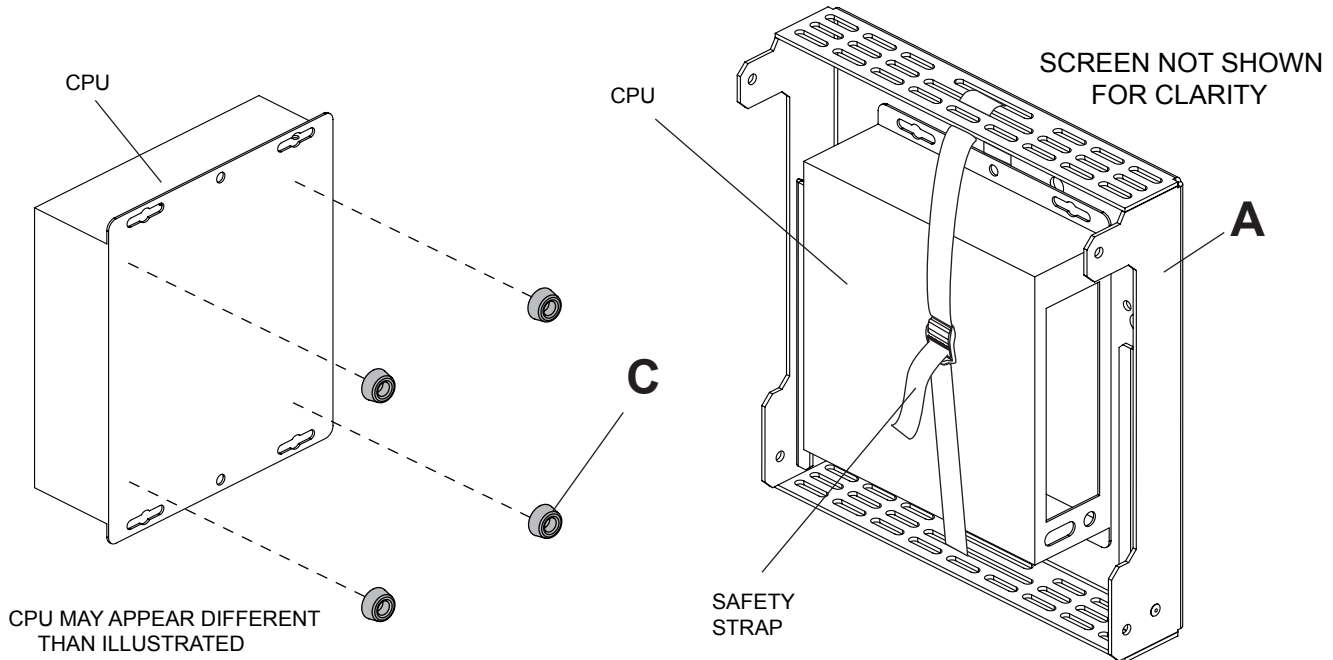

Attaching Adapter Plate to Wall Plate

- 3** Skip to Step 5 Page 8 if mounting wall plate (B) to wall.
Secure wall plate (B) to adapter plate (A) with four M8 x 15 mm screws (D) using 4 mm allen wrench (I) as shown below.

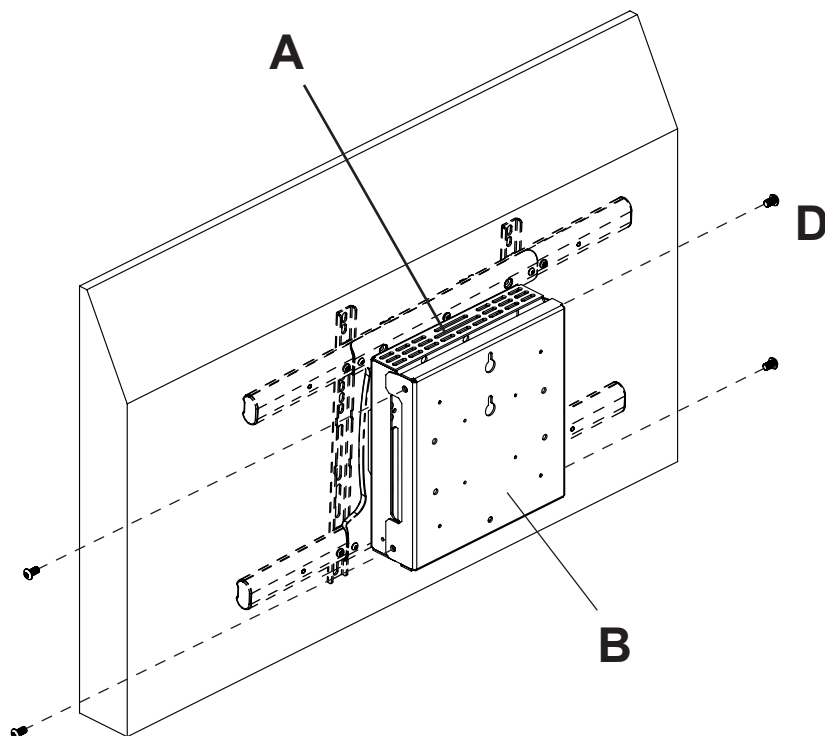

Attaching Wall Plate to Wall Arm Mount Using SP850, FPS-1000

- 4** Thread two M10 x 15 mm penta-pin screws (**E**) into top holes of wall plate (**B**) leaving 1/8" space between head of screw and wall plate as shown below. Hook wall plate (**B**) and two exposed M10 x 15 mm penta-pin screws (**E**) into keyhole slots on mount.

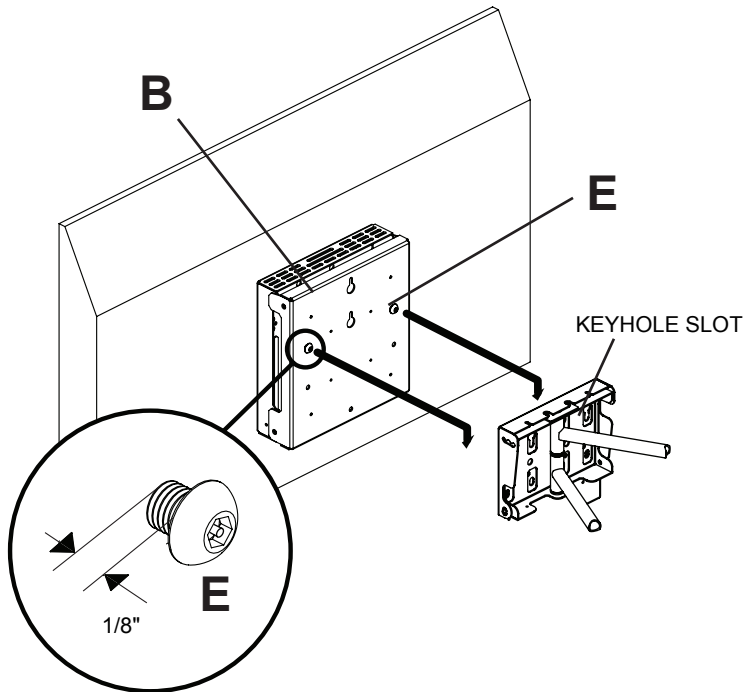

Secure with two M10 x 15 mm penta-pin screws (**E**) using M10 penta-pin tool (**F**) as shown below.

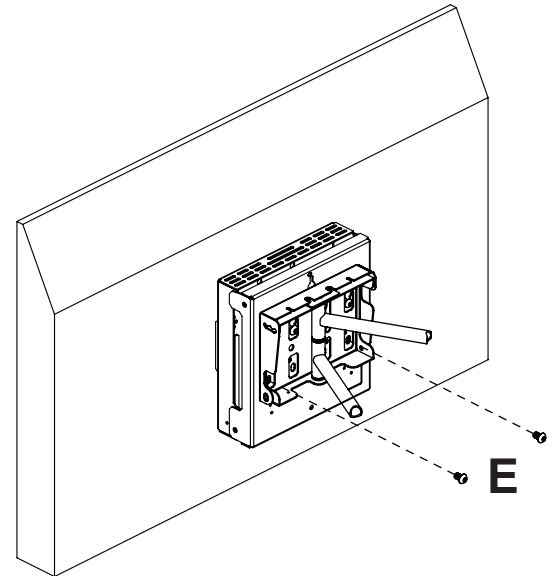

Attaching Wall Plate to Wall Arm Mount Using SA752PU, SA761PU, SA763PU, SA771PU

- 4** Thread two M10 x 15 mm penta-pin screws (**E**) into top holes of wall plate (**B**) leaving 1/8" space between head of screw and wall plate as shown below. Hook wall plate (**B**) and two exposed M10 x 15 mm penta-pin screws (**E**) into keyhole slots on mount.

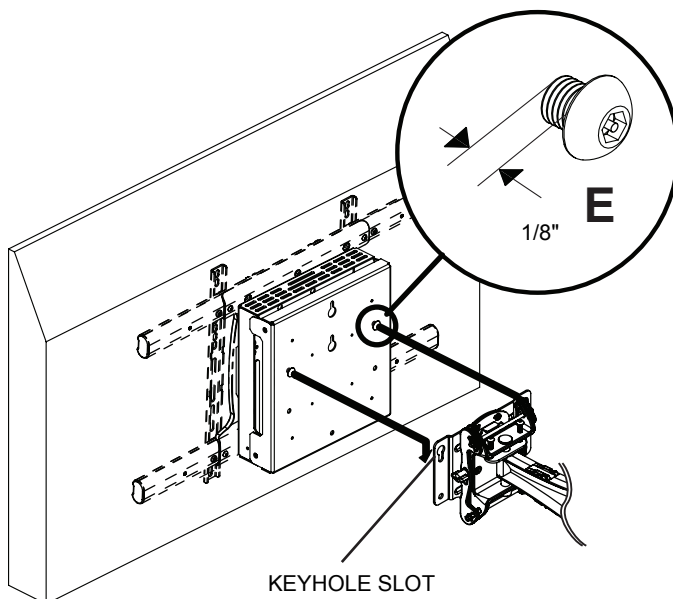

Secure with two M10 x 15 mm penta-pin screws (**E**) using M10 penta-pin tool (**F**) as shown below.

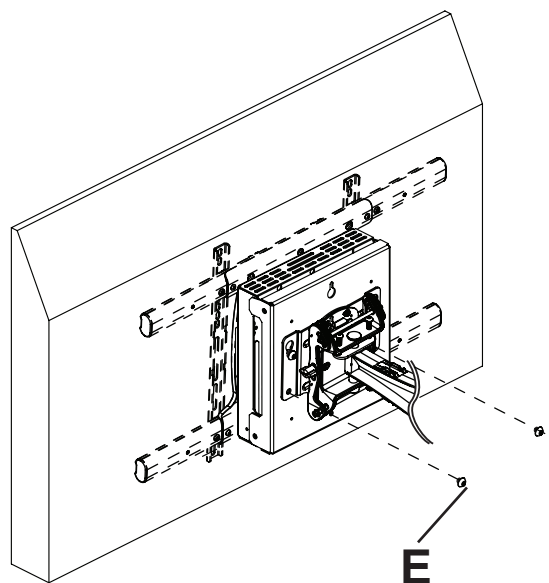

Attaching Adapter Plate to Wall Arm Mount Using SA745PU, SA750PU, SA760PU, SA770PU

- 4** Remove two M5 x 20 mm screws from the rollbrake. Lift adapter plate of wall arm mount out from tilt bracket as shown.
NOTE: M5 X 25 mm screw may need to be loosened a few turns to allow adapter bracket to be removed using 4 mm allen wrench (N).

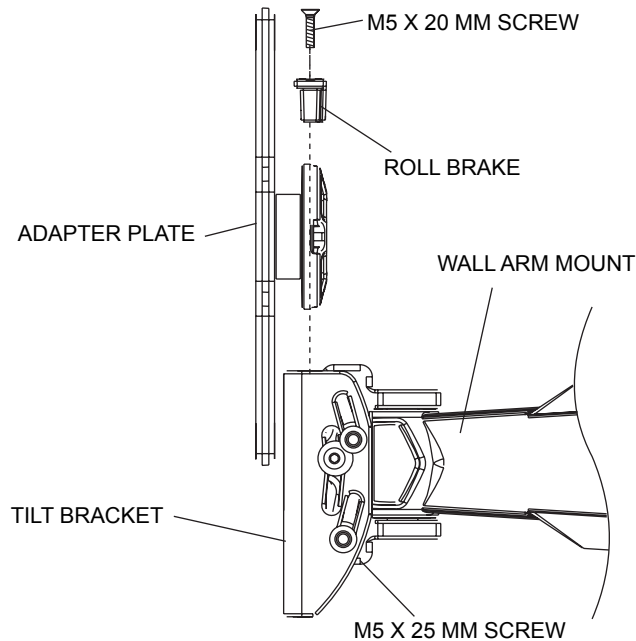

Secure adapter plate of wall arm mount to wall plate (A) with four M10 x 15 mm penta-pin screws (E) using M10 penta-pin tool (F) as shown below.

Insert the puck of adapter plate into the tilt bracket slot as shown. Attach brake pad assembly so that the brake pad is snug against the adapter plate. Adjust roll position of adapter plate to level screen then lock puck in place by tightening M5 x 25 mm screw on the underside of tilt bracket. Tighten all (M5 x 20 mm, M5 x 25 mm) screws.

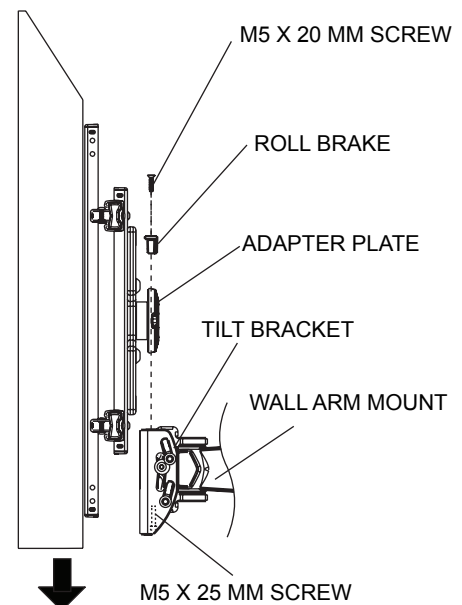
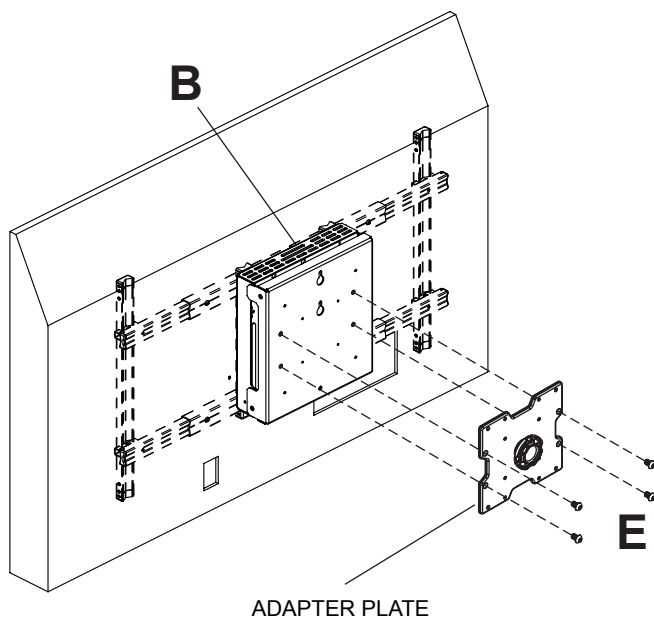

Installation to Wood Stud Wall

⚠ WARNING

- Installer must verify that the supporting surface will safely support the combined load of the equipment and all attached hardware and components.
- Tighten wood screws so that wall plate is firmly attached, but do not overtighten. Overtightening can damage the screws, greatly reducing their holding power.
- Never tighten in excess of 80 in. • lb (9 N.M.).
- Make sure that mounting screws are anchored into the center of the stud. The use of an "edge to edge" stud finder is highly recommended.
- Hardware provided is for attachment of mount through standard thickness drywall or plaster into wood studs. Installers are responsible to provide hardware for other types of mounting situations

- 5** Use a stud finder to locate the edges of the stud. Use of an edge-to-edge stud finder is highly recommended. Based on their edges, draw a vertical line down each stud center. Place wall plate (**B**) on wall as a template. Level, and mark the center of the three mounting holes. Make sure that the mounting holes are on the stud centerlines. Drill three 5/32" (4 mm) dia. holes 2.5" (64 mm) deep. Fasten two #14 x 2.5" wood screws (**O**) leaving 1/4" of thread exposed as shown in Figure 5.1. Hook wall plate (**A**) onto exposed #14 x 2.5" wood screws (**O**). Secure using one #14 x 2.5" wood screws (**O**) as shown in figure 5.2

Skip to Step 6.

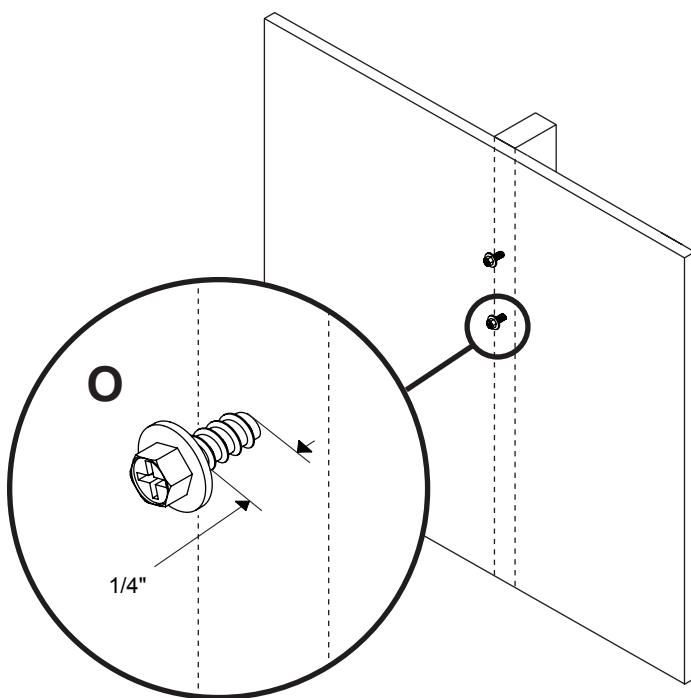

Figure 5.1

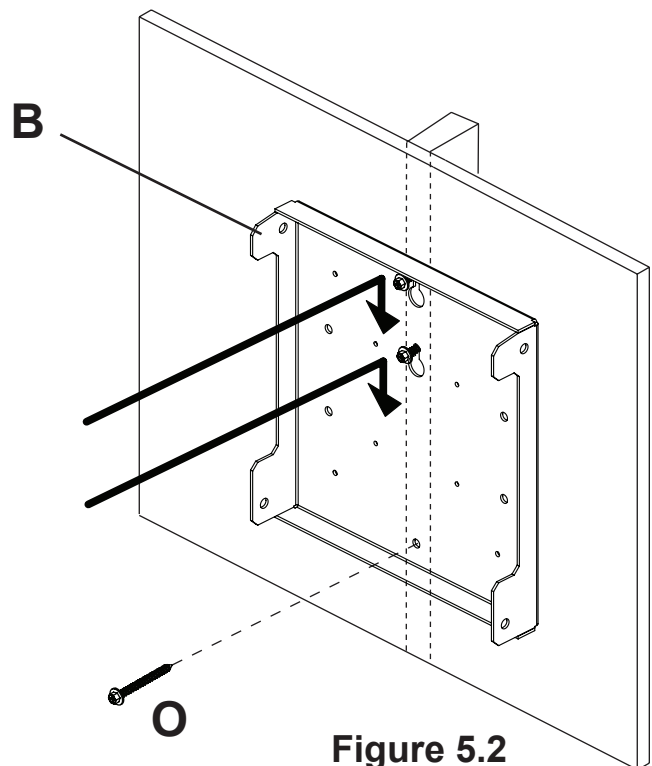

Figure 5.2

Installation to Solid Concrete or Cinder Block

⚠ WARNING

- When installing Peerless wall mounts on cinder block, verify that you have a minimum of 1-3/8" (35 mm) of actual concrete thickness in the hole to be used for the concrete anchors. Do not drill into mortar joints! Be sure to mount in a solid part of the block, generally 1" (25 mm) minimum from the side of the block. Cinder block must meet ASTM C-90 specifications. It is suggested that a standard electric drill on slow setting is used to drill the hole instead of a hammer drill to avoid breaking out the back of the hole when entering a void or cavity.
- Concrete must be 2000 psi density minimum. Lighter density concrete may not hold concrete anchor.
- Make sure that the wall will safely support four times the combined load of the equipment and all attached hardware and components.

5 Place wall plate (B) on wall as a template. Level, and mark the center of the three mounting holes. Drill three 5/16" (8 mm) dia. holes to a minimum depth of 2.5" (64 mm). Insert anchors (P) in holes flush with wall as shown. Fasten two #14 x 2.5" wood screws (O) leaving 1/4" of thread exposed as shown in Figure 5.3. Hook wall plate (A) onto exposed #14 x 2.5" wood screws (O). Secure using one #14 x 2.5" wood screws (O) as shown in figure 5.4.

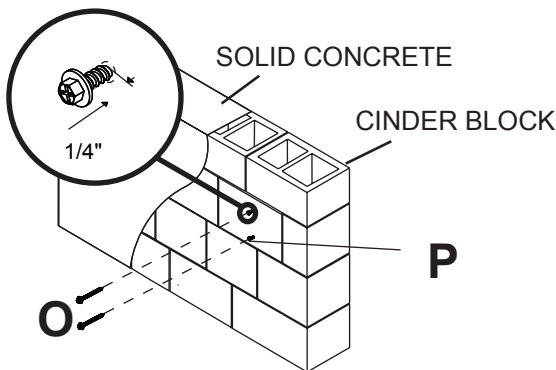

Figure 5.3

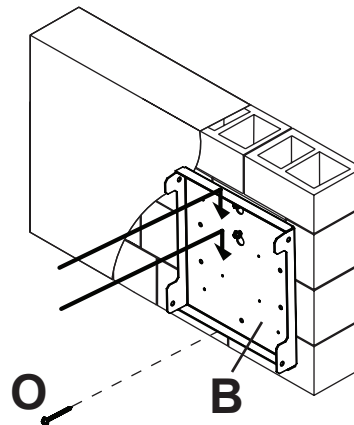
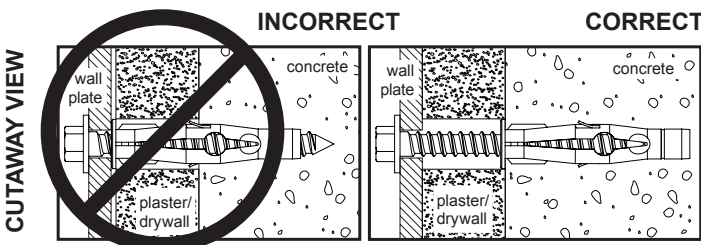
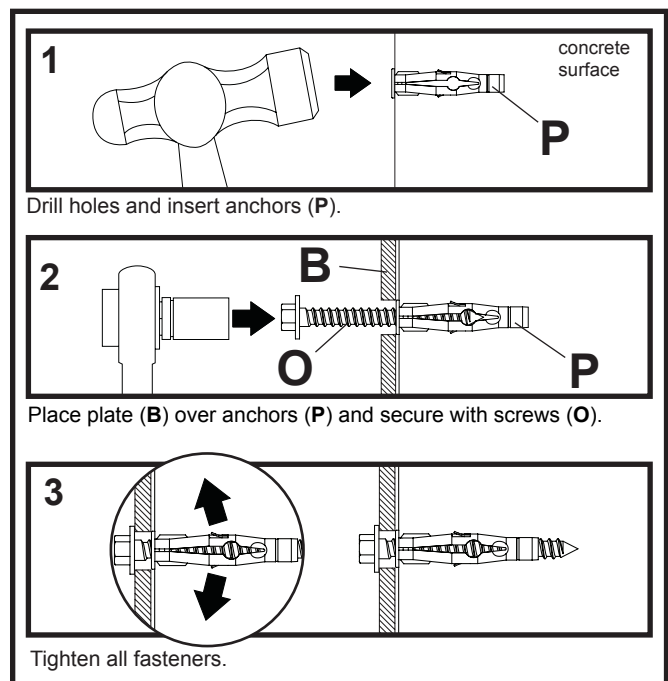

Figure 5.4

⚠ WARNING

- Tighten screws so that wall plate is firmly attached, but do not overtighten. Overtightening can damage screws, greatly reducing their holding power.
- Never tighten in excess of 80 in. • lb (9 N.M.).
- Always attach concrete expansion anchors directly to load-bearing concrete.
- Never attach concrete expansion anchors to concrete covered with plaster, drywall, or other finishing material. If mounting to concrete surfaces covered with a finishing surface is unavoidable, the finishing surface must be counterbored as shown below. Be sure concrete anchors do not pull away from concrete when tightening screws. If plaster/drywall is thicker than 5/8" (16 mm), custom fasteners must be supplied by installer.



Accessing CPU

- 6** Loosen top two M8 x 15 mm screws (**E**) 1/4 turn and temporarily remove bottom two M8 x 15 mm screws (**D**) on adapter plate (**A**) as shown in figure 6.1. Swing screen forward and swing support brackets downward into adapter plate (**B**) to brace screen in open position as shown in figure 6.2.

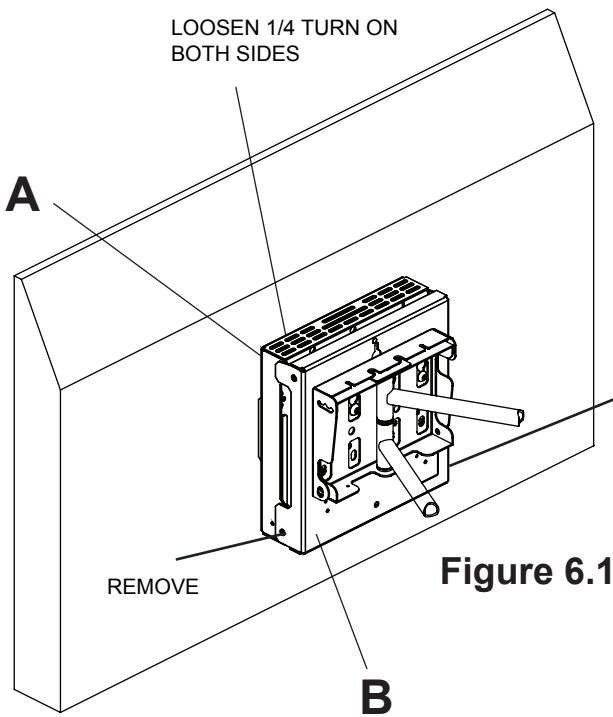

Figure 6.1

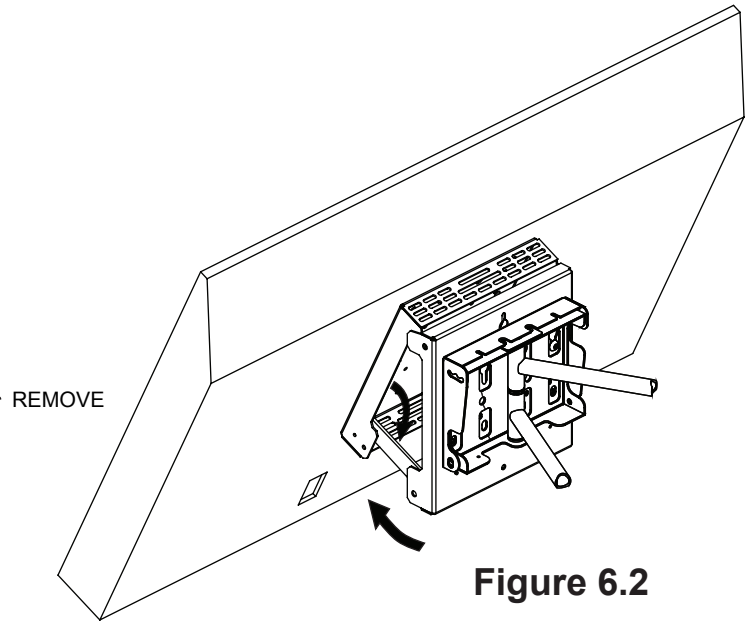

Figure 6.2