

ACC-WMVCS



Max load
15lb (6.8kg)

SMARTMOUNT

Video Conferencing Shelf Accessory

COMPATIBLE WITH STATED PEERLESS-AV® MOUNTS

Easily integrate video conferencing into a collaborative setting with the Peerless-AV® Video Conferencing Shelf Accessory. The shelf accommodates virtually any video conferencing camera and offers the choice of mounting above or below the display. Once mounted, the shelf was designed with simple adjustment to easily find the perfect camera position. All while providing a sleek, fully integrated design to match any decor, from a boardroom to a classroom.

Easily integrate video conferencing equipment into a wide range of Peerless-AV® mounts.

Additional Features

- ✓ Accommodates most conference cameras, including Polycom, LifeSize and Cisco
- ✓ Compatible with Peerless-AV® SA752PU, SA761PU, SA771PU, SAX755PU, SAX762PU, SAX772PU, SF640, SF650, SF660, ST640, ST650, ST660, SFX645, SFX650, SFX660, STX645, STX650 and STX660 mounts
- ✓ Simple height adjustment provides perfect camera positioning
- ✓ Mounts above or below the display
- ✓ Low-profile design
- ✓ Cable management slot keeps cables and cords neatly organized

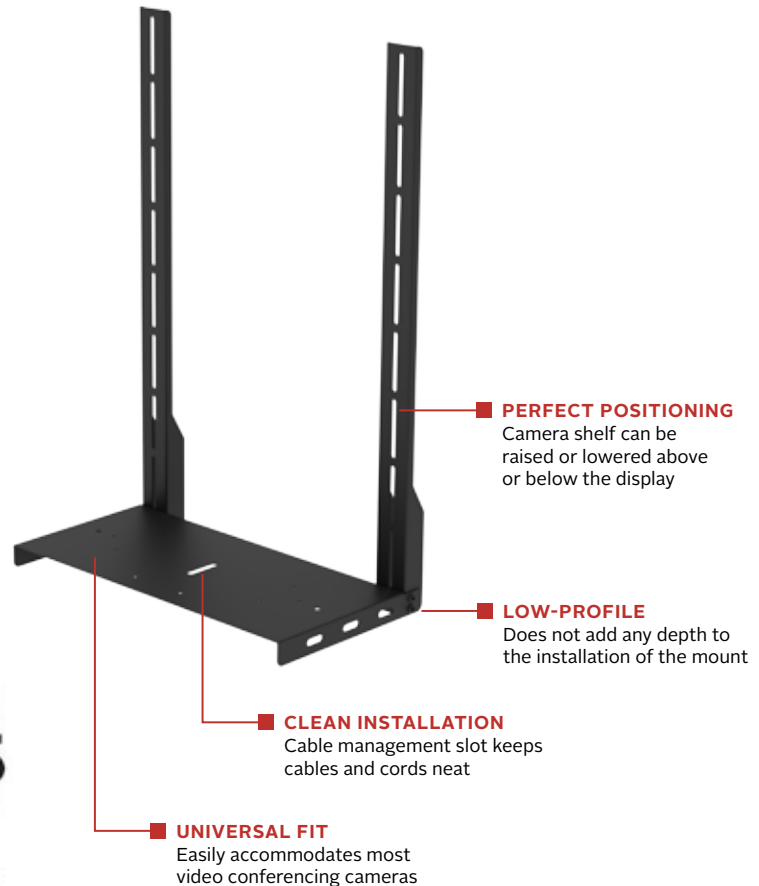

Touchboards

205 Westwood Ave, Long Branch, NJ 07740
Phone: 866-94 BOARDS (26273) / (732)-222-1511
Fax: (732)-222-7088 | E-mail: sales@touchboards.com

RoHS

info@peerless-av.com
peerless-av.com

peerless-AV®

ACC-WMVCS SmartMount® Video Conferencing Shelf Accessory compatible with Stated Peerless-AV® Mounts

Product Specifications

	DIMENSIONS (W x H x D)	PRODUCT WEIGHT	LOAD CAPACITY	FINISH	AVAILABLE COLORS
ACC-WMVCS	14.63" x 22.00" x 8.17" (371 x 559 x 208mm)	4.0lb (1.81kg)	15lb (6.8kg)	Powder Coat	Black

Package Specifications

	PACKAGE SIZE (W x H x D)	PACKAGE SHIP WEIGHT	PACKAGE UPC CODE	PACKAGE CONTENTS	UNITS IN PACKAGE
ACC-WMVCS	27.81" x 12.00" x 3.44" (706 x 305 x 87mm)	5.52lb (2.50kg)	735029311966	Camera shelf	1

Compatible with:

- SA752PU:** SmartMount® Articulating Wall Arm for 37" to 55" Displays
- SA761PU:** SmartMount® Articulating Wall Arm for 39" to 75" Displays
- SA771PU:** SmartMount® Articulating Wall Arm for 46" to 90" Displays
- SAX755PU:** SmartmountXT™ Articulating Wall Arm for 37" to 55" Displays
- SAX762PU:** SmartmountXT™ Articulating Wall Arm for 39" to 75" Displays
- SAX772PU:** SmartmountXT™ Articulating Wall Arm for 46" to 90" Displays
- SF640:** SmartMount® Universal Flat Wall Mount for 32" to 50" Displays
- SF650:** SmartMount® Universal Flat Wall Mount for 39" to 75" Displays
- SF660:** SmartMount® Universal Flat Wall Mount for 39" to 80" Displays
- ST640:** SmartMount® Universal Tilt Wall Mount for 32" to 50" Displays
- ST650:** SmartMount® Universal Tilt Wall Mount for 39" to 75" Displays
- ST660:** SmartMount® Universal Tilt Wall Mount for 39" to 80" Displays
- SFX645:** SmartmountXT™ Universal Flat Wall Mount for 32" to 60" Displays
- SFX650:** SmartmountXT™ Universal Flat Wall Mount for 37" to 75" Displays
- SFX660:** SmartmountXT™ Universal Flat Wall Mount for 39" to 90" Displays
- STX645:** SmartmountXT™ Universal Tilt Wall Mount for 32" to 60" Displays
- STX650:** SmartmountXT™ Universal Tilt Wall Mount for 37" to 75" Displays
- STX660:** SmartmountXT™ Universal Tilt Wall Mount for 39" to 90" Displays

All dimensions = inch (mm)

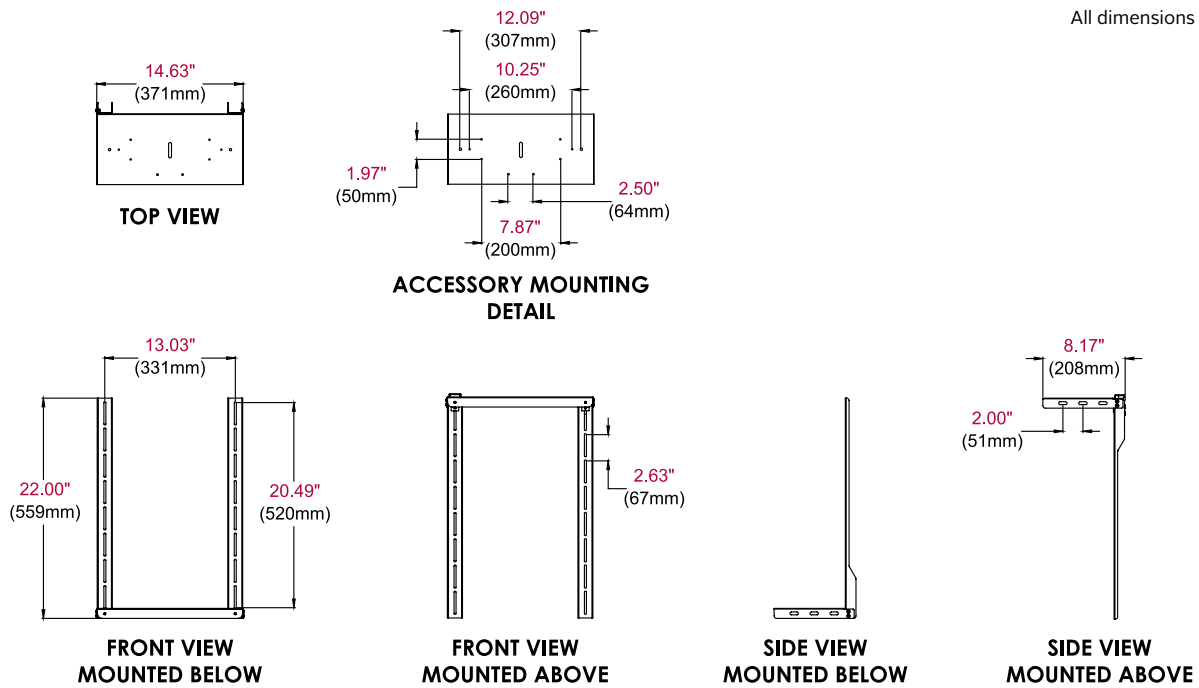

Architect Specifications

The SmartMount® Video Conferencing Shelf Accessory shall be a Peerless-AV® model ACC-WMVCS and shall be located where indicated on the plans. Assembly and installation shall be done according to instructions provided by the manufacturer.

Visit peerless-av.com to see the complete line of AV solutions from Peerless-AV, including outdoor displays, wireless, kiosks, digital audio, display mounts, projector mounts, carts/stands, and a full assortment of accessories.

Peerless-AV
2300 White Oak Circle
Aurora, IL 60502 USA

(800) 865-2112
(630) 375-5100
Fax: (800) 359-6500

Peerless-AV Europe
Unit 3 Watford Interchange
Colonial Way, Watford
Herts, WD24 4WP
United Kingdom
+44 (0) 1923 200100
Fax: +44 (0) 1923 200101

Peerless-AV de México
Ave de las Industrias 413
Parque Industrial Escobedo
Escobedo, N.L.,
Mexico 66050
+52 (81) 8384-8300
Fax: +52 (81) 8384-8360

