

TECHNICAL DATA SHEET -**MODEL: MIS517**

peerless®
MOUNTS

DVD/VCR Mount Connector

The MIS517 is designed to hold a DVD/VCR flush with the bottom of the TV. The open back design and horizontal adjustability prevents blocking of connection points on the back of the screen.

Features:

- Connects Peerless articulating, pivot and ceiling mounts to DVD/VCR mounts
- Accommodates VESA 75x75, 100x100 and 100x200 hole patterns
- Screw attachment location provides theft deterrence when DVD/VCR is installed
- Can be installed without removing mount from the wall
- Height adjustability allows the DVD/VCR to sit flush with the TV
- Open back design prevents the blocking of connection points

Dimensions:**Weight:**

3.98 lbs (1.5 kg)

Shipping weight:

5.4 lbs (2.01 kg)

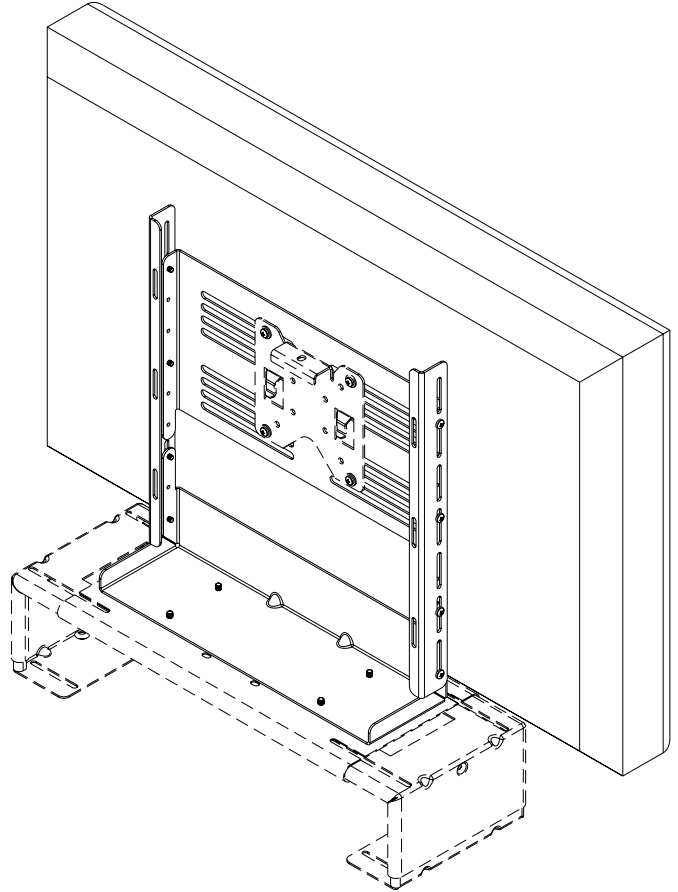
Shipping Carton dimensions:**L** = 20.25 in (514 mm)**W** = 12.25 in (311 mm)**H** = 4 in (102 mm)

Touchboards

205 Westwood Ave, Long Branch, NJ 07740

Phone: 866-94 BOARDS (26273) / (732)-222-1511

Fax: (732)-222-7088 | E-mail: sales@touchboards.com

ARCHITECTS SPECIFICATIONS

The DVD/VCR Mount Connector shall be a Peerless model **MIS517** and shall be located where indicated on the plans. It shall be constructed of heavy gauge cold rolled steel and feature scratch resistant gloss black fused epoxy finish. Assembly and installation shall be done according to instructions provided by the manufacturer.

Peerless Industries, Inc.

3215 W. North Ave. Melrose Park, IL 60160

708-865-8870 800-865-2112 Fax 708-865-2941

www.peerlessmounts.com**ISSUED: 10-09-08 SHEET NO: 124-9518-1**

TECHNICAL DATA SHEET

MODEL: MIS517

ALL DIMENSIONS: inch [mm]

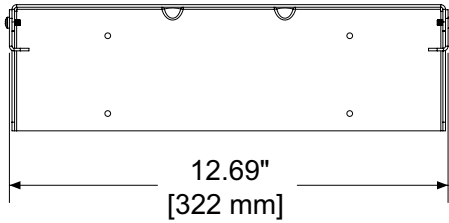

TOP VIEW

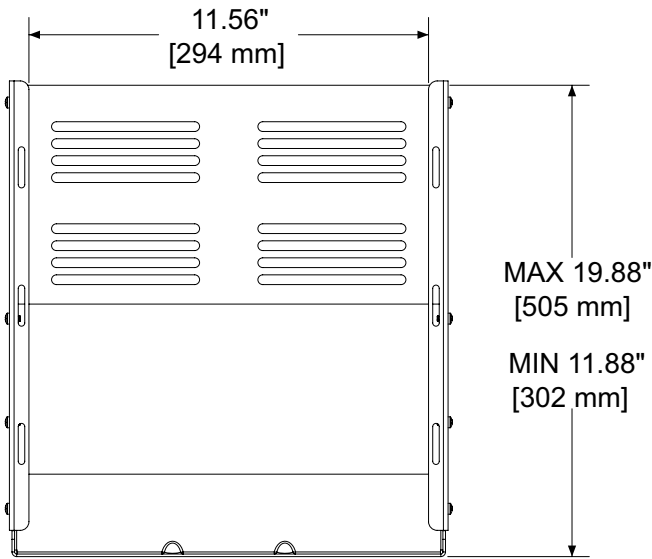

FRONT VIEW

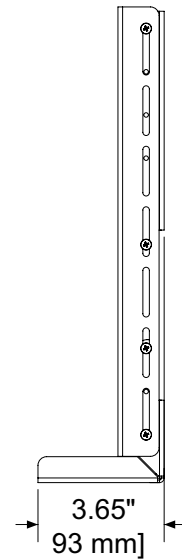

SIDE VIEW

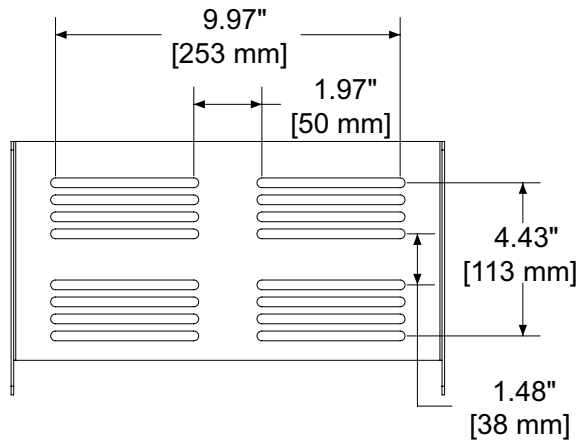

HANGING BRACKET DETAIL