

## AEC MODELS



Max load  
**500lb (227kg)**

# Touchboards

205 Westwood Ave, Long Branch, NJ 07740  
Phone: 866-94 BOARDS (26273) / (732)-222-1511  
Fax: (732)-222-7088 | E-mail: sales@touchboards.com

# Adjustable Extension Column

FOR USE WITH PEERLESS-AV® DISPLAY MOUNTS,  
PROJECTOR MOUNTS AND CEILING PLATE ACCESSORIES

Designed to blend in and work in almost any environment, our line of AEC adjustable columns range in lengths from 6-9" up to 10-12'. Whether it's for an office or mounted from a tall cathedral ceiling, the adjustable column supports up to 500lb, making it ideal for exhibit, retail or digital signage applications. The adjustment slot design makes for easy incremental height adjustments to find the perfect position and then securely locking it into place. The AEC column's cylinder shape conveniently offers ample internal space for cable management of multiple cords, ultimately giving a clean look to any installation.

*The AEC's adjustment slot design makes for easy incremental height adjustments to perfectly place your display, and lock it into place.*



## Additional Features

- ✓ 1-1/2"-11.5 NPT (38mm) aluminum column threaded on both ends
- ✓ Height adjustment at 1" (25mm) increments
- ✓ Lightweight aluminum construction for ease of installation and lower freight cost
- ✓ Offers unobtrusive cable management
- ✓ Notched adjustment design enables easy height adjustment and position locking
- ✓ Agion® antimicrobial\* finish assists in controlling the spread of infections with -AB/-AW models

\*Antimicrobial protection is limited to the treated article and does not protect a user against disease causing bacteria. Always clean products thoroughly after each use. Visit [agion-tech.com](http://agion-tech.com) for more details.



**EASE OF ADJUSTABILITY**  
Simplest slot design allows for easy glide adjustment

**CABLE MANAGEMENT**  
Allows added capability for routing cables



Cable management



Available in black, silver or white to match displays, projectors and ceiling mount surfaces



RoHS



# Model Numbers

**WARRANTY: Limited 5-year**

**AEC Models:** Adjustable Extension Column for use with Peerless-AV® Display Mounts, Projector Mounts and Ceiling Plate Accessories

## Product Specifications

|                             | DIMENSIONS (COLUMN LENGTH) | PRODUCT WEIGHT  | LOAD CAPACITY | FINISH                                    | AVAILABLE COLORS                                |
|-----------------------------|----------------------------|-----------------|---------------|---|---|
| AEC006009(-S)(-W)(-AB)(-AW) | 6"-9" (0.15-0.23m)         | 1.0lb (0.45kg)  | 500lb (227kg) | Powder Coat or Antimicrobial* Powder Coat | AEC006009 - AEC1012: Black                      |
| AEC009012(-S)(-W)(-AB)(-AW) | 9"-12" (0.23-0.30m)        | 1.2lb (0.55kg)  |               |   | AEC006009-S - AEC1012-S: Silver                 |
| AEC012018(-S)(-W)(-AB)(-AW) | 12"-18" (0.30-0.46m)       | 1.8lb (0.82kg)  |               |   | AEC006009-W - AEC1012-W: White                  |
| AEC018024(-S)(-W)(-AB)(-AW) | 18"-24" (0.46-0.61m)       | 2.3lb (1.05kg)  |               |   | AEC006009-AB - AEC1012-AB: Antimicrobial* Black |
| AEC0203(-S)(-W)(-AB)(-AW)   | 2'-3" (0.61-0.91m)         | 3.2lb (1.45kg)  |               |   | AEC006009-AW - AEC1012-AW: Antimicrobial* White |
| AEC0305(-S)(-W)(-AB)(-AW)   | 3'-5" (0.91-1.52m)         | 5.5lb (2.50kg)  |               |   |   |
| AEC0406(-S)(-W)(-AB)(-AW)   | 4'-6" (1.22-1.83m)         | 7.6lb (3.45kg)  |               |   |   |
| AEC0507(-S)(-W)(-AB)(-AW)   | 5'-7" (1.52-2.13m)         | 8.4lb (3.82kg)  |               |   |   |
| AEC0608(-S)(-W)(-AB)(-AW)   | 6'-8" (1.83-2.44m)         | 9.2lb (4.12kg)  |               |   |   |
| AEC0810(-S)(-W)(-AB)(-AW)   | 8'-10" (2.44-3.05m)        | 11.0lb (5.00kg) |               |   |   |
| AEC1012(-S)(-W)(-AB)(-AW)   | 10'-12" (3.05-3.66m)       | 12.8lb (5.82kg) |               |   |   |

\*Antimicrobial protection is limited to the treated article and does not protect a user against disease causing bacteria. Always clean products thoroughly after each use. Visit agion-tech.com for more details.

## Package Specifications

|                             | PACKAGE SIZE (D x L)    | PACKAGE SHIP WEIGHT | PACKAGE UPC CODE           |                          | PACKAGE CONTENTS                                       | UNITS IN PACKAGE |
|-----------------------------|-------------------------|---------------------|----------------------------|--------------------------|--|------------------|
| AEC006009(-S)(-W)(-AB)(-AW) | 3" x 9" (76 x 228mm)    | 1.3lb (0.59kg)      | AEC006009: 735029275121    | AEC0305-AB: 735029303657 | Extension column, adjuster column and M8 x 10 mm screw | 1                |
| AEC009012(-S)(-W)(-AB)(-AW) | 3" x 12" (76 x 304mm)   | 1.6lb (0.73kg)      | AEC006009-S: 735029275138  | AEC0305-AW: 735029303664 |  |                  |
| AEC012018(-S)(-W)(-AB)(-AW) | 3" x 14" (76 x 355mm)   | 2.2lb (1.00kg)      | AEC006009-W: 735029275145  | AEC0406: 735029267041    |  |                  |
| AEC018024(-S)(-W)(-AB)(-AW) | 3" x 21" (76 x 533mm)   | 2.9lb (1.32kg)      | AEC009012-AB: 735029303558 | AEC0406-S: 735029267232  |  |                  |
| AEC0203(-S)(-W)(-AB)(-AW)   | 3" x 27" (76 x 685mm)   | 4.1lb (1.86kg)      | AEC006009-AW: 735029303572 | AEC0406-W: 735029267140  |  |                  |
| AEC0305(-S)(-W)(-AB)(-AW)   | 3" x 41" (76 x 1041mm)  | 6.7lb (3.05kg)      | AEC009012-S: 735029302476  | AEC0406-AB: 735029303671 |  |                  |
| AEC0406(-S)(-W)(-AB)(-AW)   | 3" x 48" (76 x 1219mm)  | 9.1lb (4.14kg)      | AEC009012-S: 735029302483  | AEC0406-AW: 735029303688 |  |                  |
| AEC0507(-S)(-W)(-AB)(-AW)   | 3" x 61" (76 x 1549mm)  | 10.4lb (4.73kg)     | AEC009012-W: 735029302490  | AEC0507: 735029302506    |  |                  |
| AEC0608(-S)(-W)(-AB)(-AW)   | 3" x 73" (76 x 1854mm)  | 11.4lb (5.18kg)     | AEC009012-AB: 735029303589 | AEC0507-S: 735029302513  |  |                  |
| AEC0810(-S)(-W)(-AB)(-AW)   | 3" x 97" (76 x 2464mm)  | 13.9lb (6.32kg)     | AEC009012-AW: 735029303596 | AEC0507-W: 735029302520  |  |                  |
| AEC1012(-S)(-W)(-AB)(-AW)   | 3" x 120" (76 x 3048mm) | 16.0lb (7.27kg)     | AEC012018: 735029275152    | AEC0507-AB: 735029303695 |  |                  |
|                             |                         |                     | AEC012018-S: 735029275169  | AEC0507-AW: 735029303701 |  |                  |
|                             |                         |                     | AEC012018-W: 735029275176  | AEC0608: 735029267058    |  |                  |
|                             |                         |                     | AEC012018-AB: 735029303602 | AEC0608-S: 735029267249  |  |                  |
|                             |                         |                     | AEC012018-AW: 735029303655 | AEC0608-W: 735029267157  |  |                  |
|                             |                         |                     | AEC018024: 735029275183    | AEC0608-AB: 735029303718 |  |                  |
|                             |                         |                     | AEC018024-S: 735029275190  | AEC0608-AW: 735029303725 |  |                  |
|                             |                         |                     | AEC018024-W: 735029275206  | AEC0810: 735029267065    |  |                  |
|                             |                         |                     | AEC018024-AB: 735029303619 | AEC0810-S: 735029267256  |  |                  |
|                             |                         |                     | AEC018024-AW: 735029303626 | AEC0810-W: 735029267164  |  |                  |
|                             |                         |                     | AEC0203: 735029267027      | AEC0810-AB: 735029303732 |  |                  |
|                             |                         |                     | AEC0203-S: 735029267218    | AEC0810-AW: 735029303749 |  |                  |
|                             |                         |                     | AEC0203-W: 735029267126    | AEC1012: 735029267072    |  |                  |
|                             |                         |                     | AEC0203-AB: 735029303633   | AEC1012-S: 735029267263  |  |                  |
|                             |                         |                     | AEC0203-AW: 735029303640   | AEC1012-W: 735029267171  |  |                  |
|                             |                         |                     | AEC0305: 735029267034      | AEC1012-AB: 735029303756 |  |                  |
|                             |                         |                     | AEC0305-S: 735029267225    | AEC1012-AW: 735029303763 |  |                  |
|                             |                         |                     | AEC0305-W: 735029267133    |                          |  |                  |

All dimensions = inch (mm)

| MODEL     | Drop Length (x)                   |
|-----------|-----------------------------------|
| AEC006009 | 6.00" - 9.00" (152 - 228mm)       |
| AEC009012 | 9.00" - 12.00" (228 - 304mm)      |
| AEC012018 | 12.00" - 18.00" (304 - 457mm)     |
| AEC18024  | 18.00" - 24.00" (457 - 609mm)     |
| AEC0203   | 24.00" - 36.00" (609 - 914mm)     |
| AEC0305   | 36.00" - 60.00" (914 - 1524mm)    |
| AEC0406   | 48.00" - 72.00" (1219 - 1828mm)   |
| AEC0507   | 60.00" - 84.00" (1524 - 2133mm)   |
| AEC0608   | 72.00" - 96.00" (1828 - 2438mm)   |
| AEC0810   | 96.00" - 120.00" (2438 - 3048mm)  |
| AEC1012   | 120.00" - 144.00" (3048 - 3657mm) |

\*overall length is 1.0" (25.4mm) longer than drop length

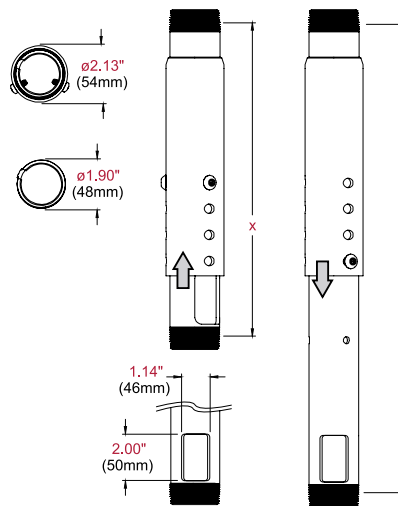

## Architect Specifications

The Adjustable Extension Column shall be a Peerless-AV model AEC% and shall be located where indicated on the plans. Assembly and installation shall be done according to instructions provided by the manufacturer.

Visit [peerless-av.com](http://peerless-av.com) to see the complete line of AV solutions from Peerless-AV, including outdoor displays, wireless, kiosks, digital audio, display mounts, projector mounts, carts/stands, and a full assortment of accessories.

**Peerless-AV**  
2300 White Oak Circle  
Aurora, IL 60502 USA  
  
**(800) 865-2112**  
**(630) 375-5100**  
**Fax: (800) 359-6500**

**Peerless-AV Europe**  
Unit 3 Watford Interchange  
Colonial Way, Watford  
Herts, WD24 4WP  
United Kingdom  
**+44 (0) 1923 200100**  
**Fax: +44 (0) 1923 200101**

**Peerless-AV de México**  
Ave de las Industrias 413  
Parque Industrial Escobedo  
Escobedo, N.L.,  
Mexico 66050  
**+52 (81) 8384-8300**  
**Fax: +52 (81) 8384-8360**

