

Installation and Assembly: **Back to Back Ceiling Mount**

Model: DST965

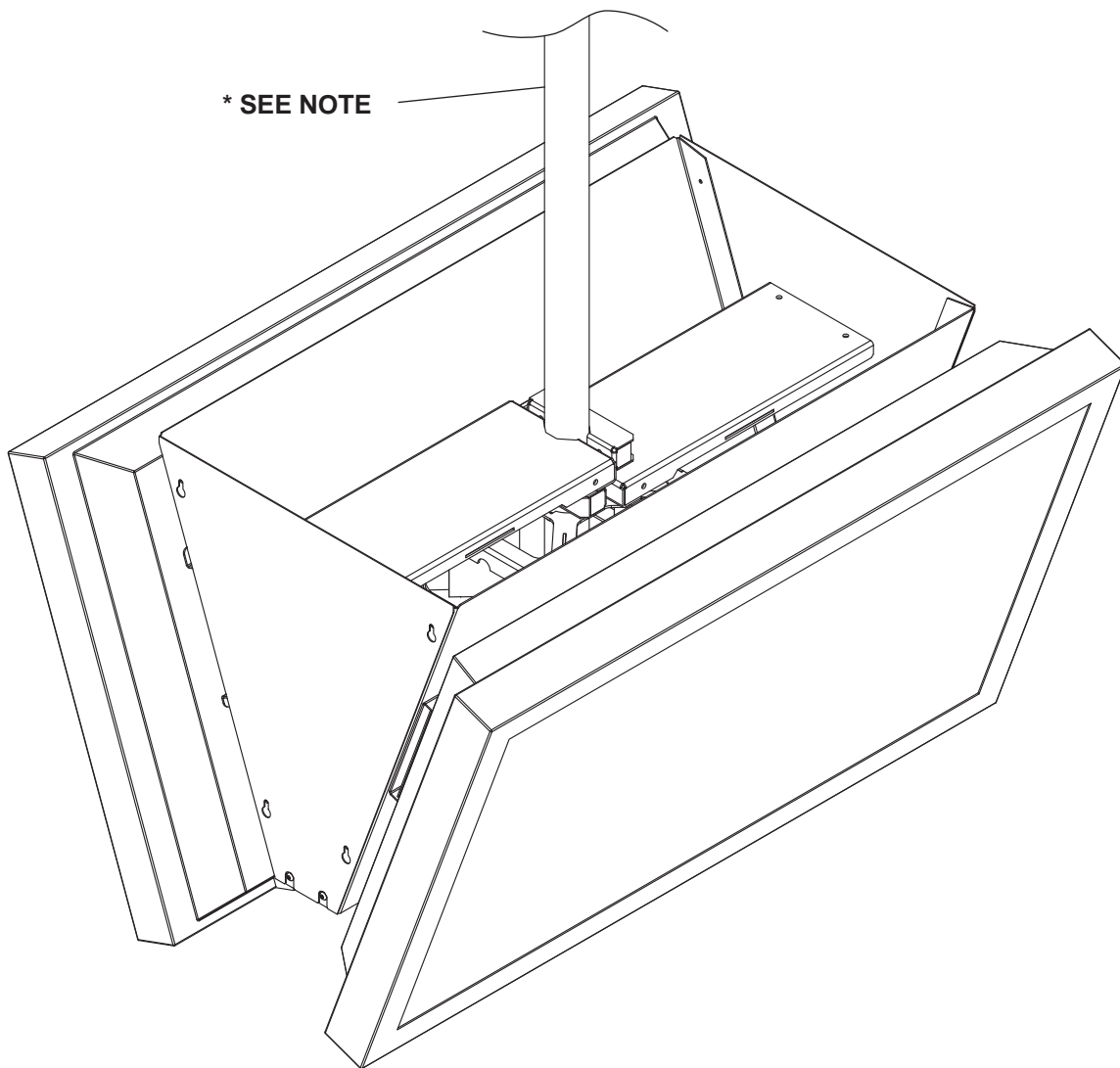

*** NOTE: DST965 WILL NOT WORK WITH ADJUSTABLE
EXTENSION COLUMNS AEC006009, OR AEC012018**

Maximum Load Capacity: 300 lb (136 kg)

Before you start make sure all parts listed are included with your product.

PARTS LIST			
	Description	Qty.	Part #
A	main cover	2	145-1452
B	side cover	2	145-1453
C	cable assembly	1	600-0033
D	adapter bracket	4	202-1655
E	component shelf clamp	2	145-1180
F	bottom bracket	1	145-1454
G	component shelf	2	145-1179
H	M5 x 10 mm socket pin type-F screw	12	520-1164
I	1/4-20 X 2" socket screw	4	520-1010
J	cable wire clamp	1	560-0104
K	cable bracket	2	145-1178
L	safety belt (not shown)	1	170-8039-1
M	adapter plate	2	201-1110
N	4 mm security driver tool	1	560-1133
O	interface bracket	1	200-1090
P	tilt bracket	2	200-1552
Q	M10 x 1.5 x 15 mm penta-pin™ screw	16	520-9263
R	M5 x .8 x 10 mm self-tapping penta-pin screw	1	505-9010
S	#8 x 3/8" truss head sheet metal screw	1	520-1078
T	M10 x 2" penta-pin tool	1	520-9260
U	M5 x 1" penta-pin tool	1	520-9249
V	2.125" ID x 2.875" OD x .062" H fiber washer	1	540-9432
W	retaining collar	1	1800-375
X	18" allen wrench	1	560-1727

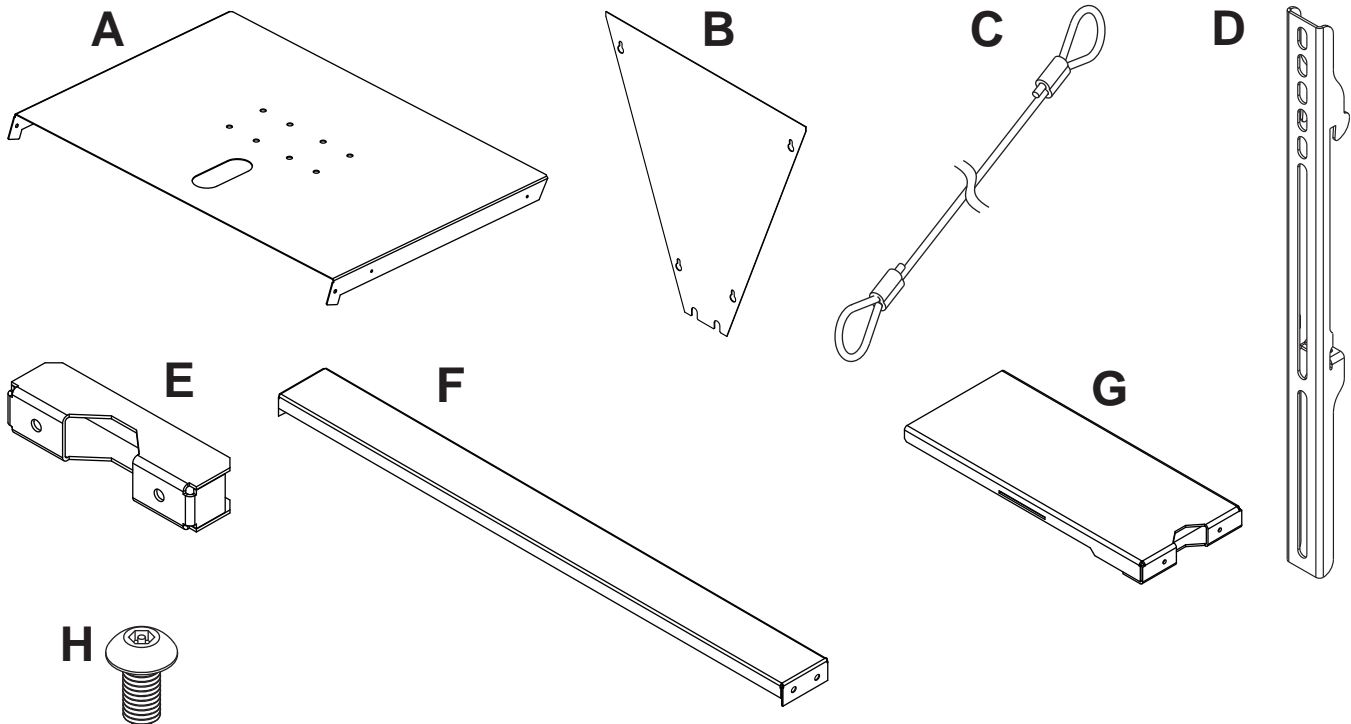

Some parts may appear slightly different than illustrated.

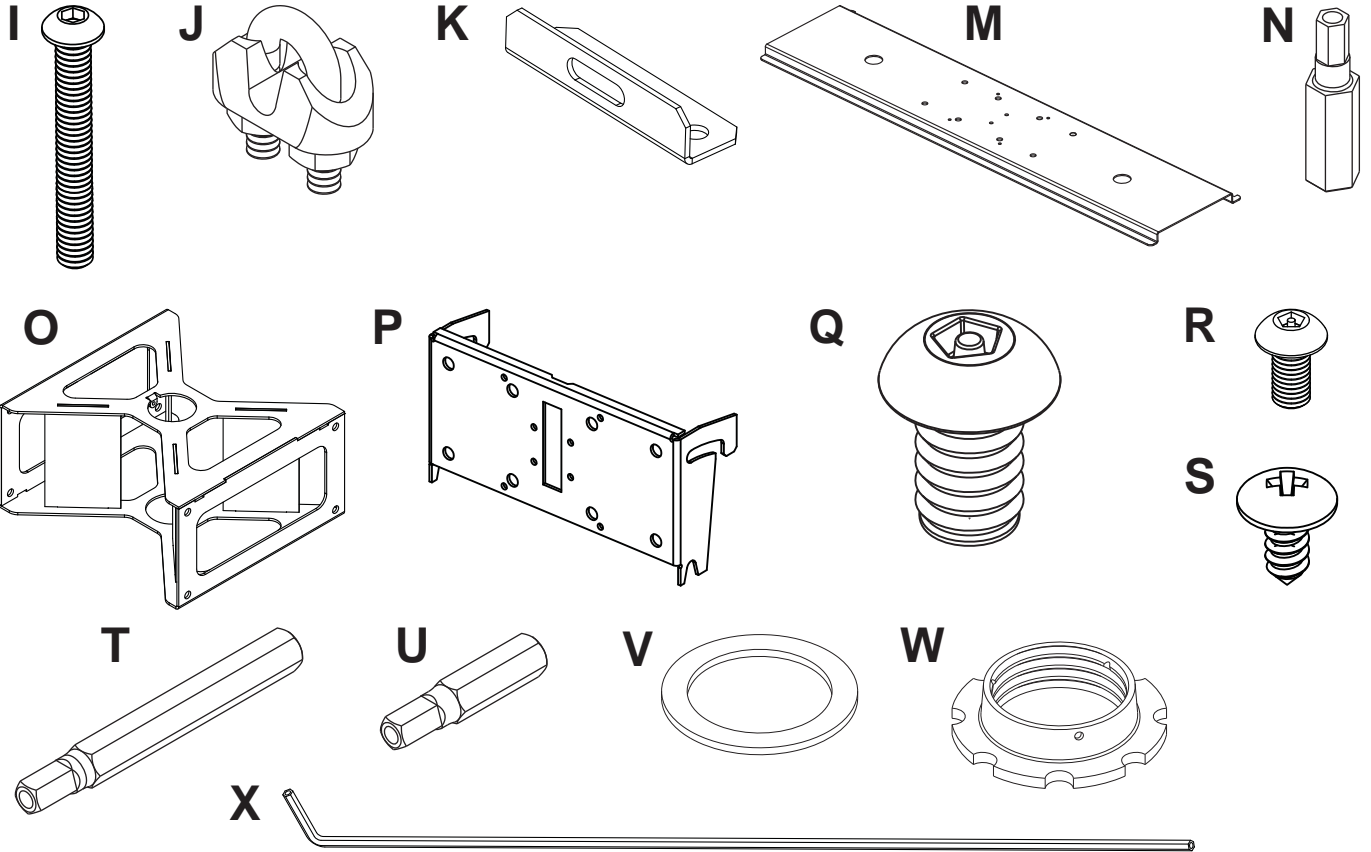

Security Adapter Bracket Fasteners

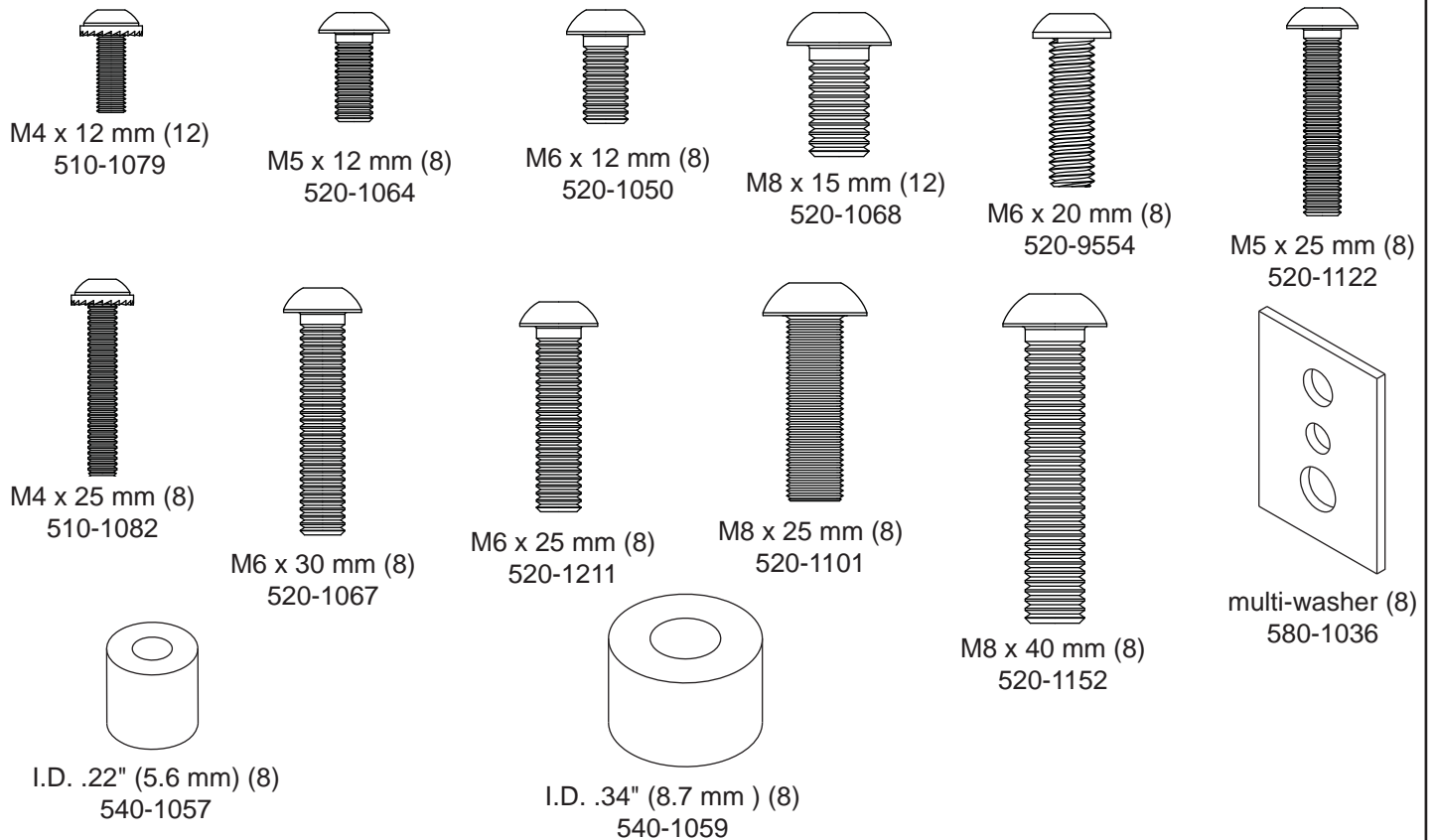

1

Note: Notch indicates bottom of interface bracket (O) as shown in detail 1.

Slide interface bracket (O) onto adjustable extension column (**not supplied**) and attach using fiber washer (V) and retaining collar (W) as shown in figure 1.1.

Carefully thread retaining collar (W) onto end of extension column. Tighten retaining collar (W) at least four complete turns ending with one of the small holes aligned with slot in the end of extension column. Insert and tighten M5 x 10 mm penta-pin screw (R) using M5 x 1" penta-pin tool (U) as shown in figure 1.2.

Secure Interface bracket (O) into place using one #8 x 3/8" truss head sheet metal screw (S) as shown in detail 2.

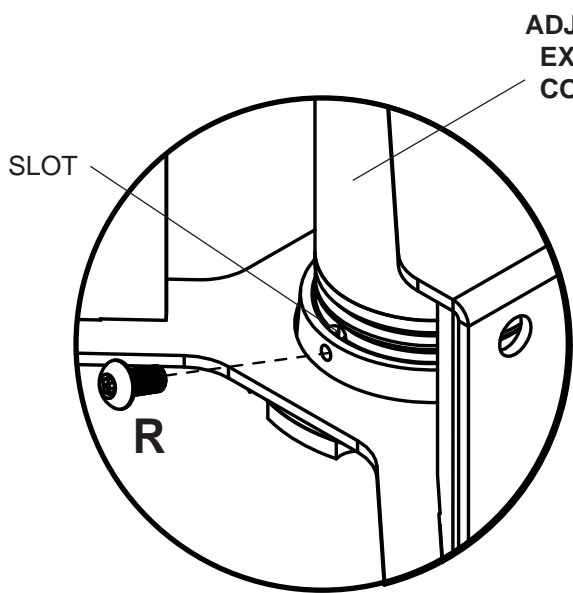

Figure 1.2

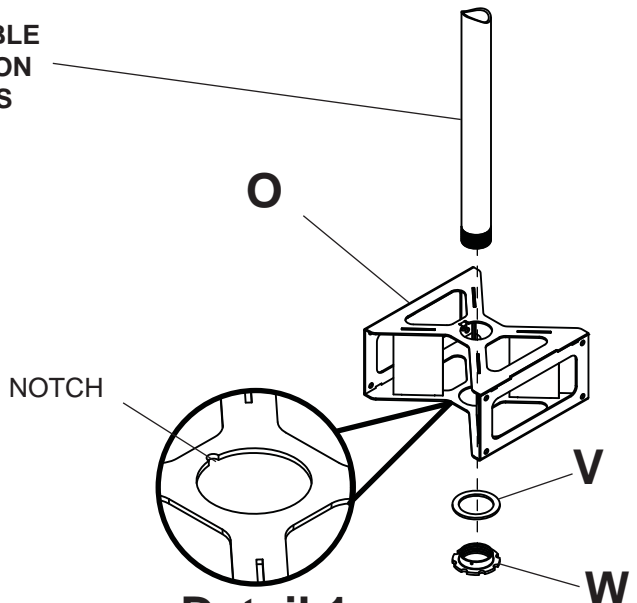
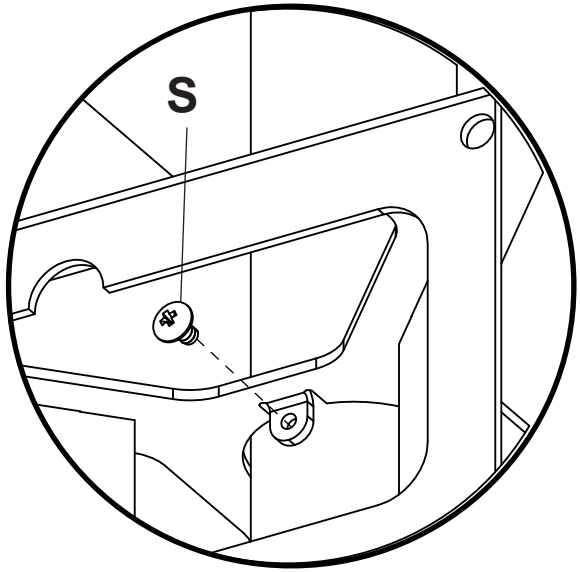
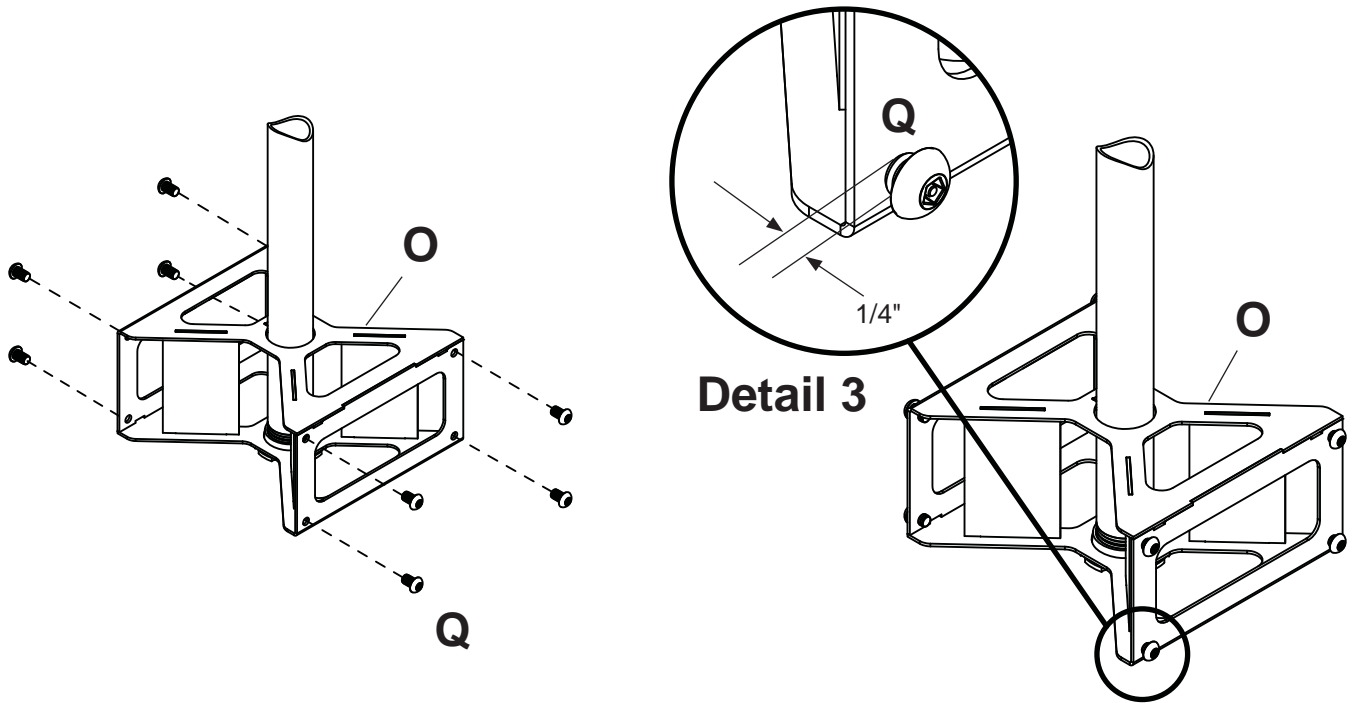

Figure 1.1



Detail 2

- 2 Screw eight M10 x 15 mm penta-pin screws (Q) into interface bracket (O) leaving approximately 1/4" of exposed thread as shown below and in detail 3.



Attaching Component Shelf

- 3 Secure two component shelves (G) to adjustable extension column (not supplied) using two component shelf clamps (E) and four 1/4-20 X 2" socket screws (I).

NOTE: Make sure that component shelves are in the orientation as shown in detail 4.

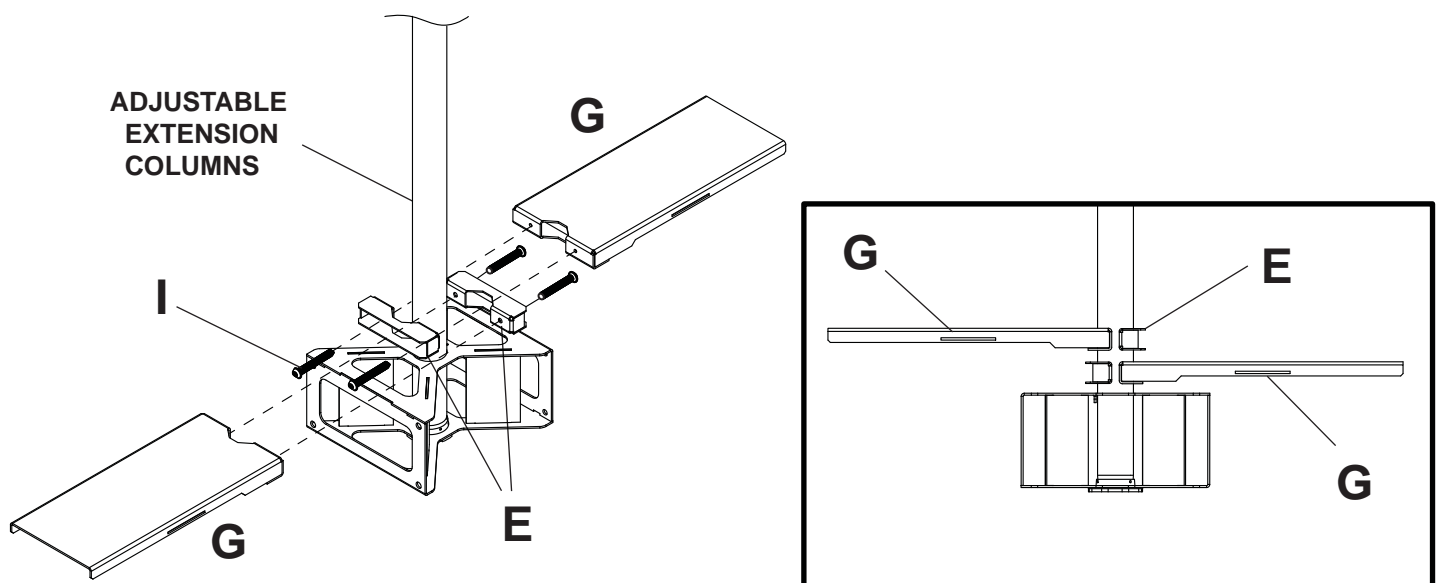

Detail 4

- 4 Secure four M10 x 15 mm penta-pin screws (**Q**) through cable bracket (**K**), tilt plate (**P**), main cover (**A**), and adapter plate (**M**), and as shown below. Repeat with second support assembly.

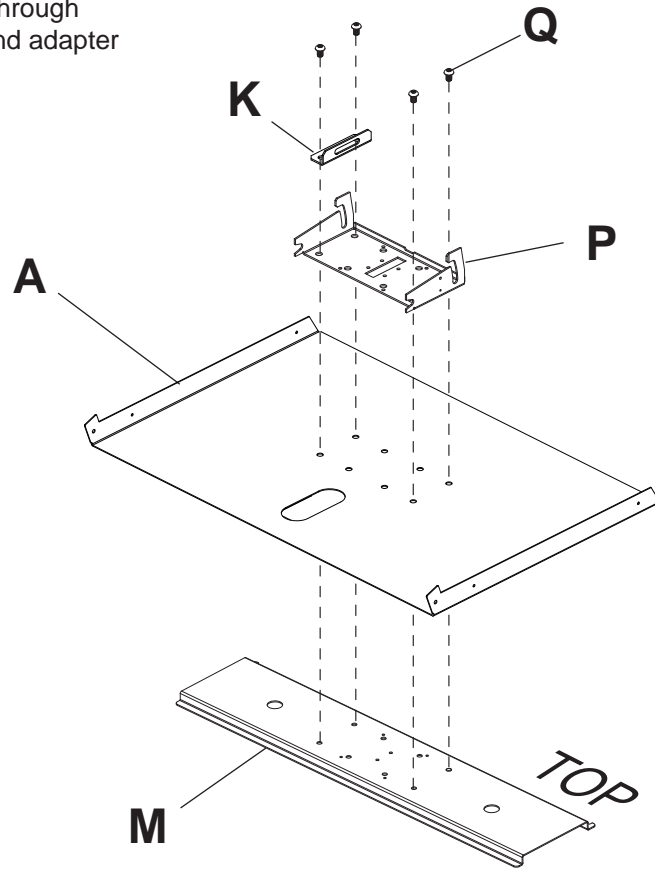

- 5 Hook tilt plate (**P**) and support assembly onto M10 x 15 mm penta-pin screws (**Q**). Repeat with second support assembly.

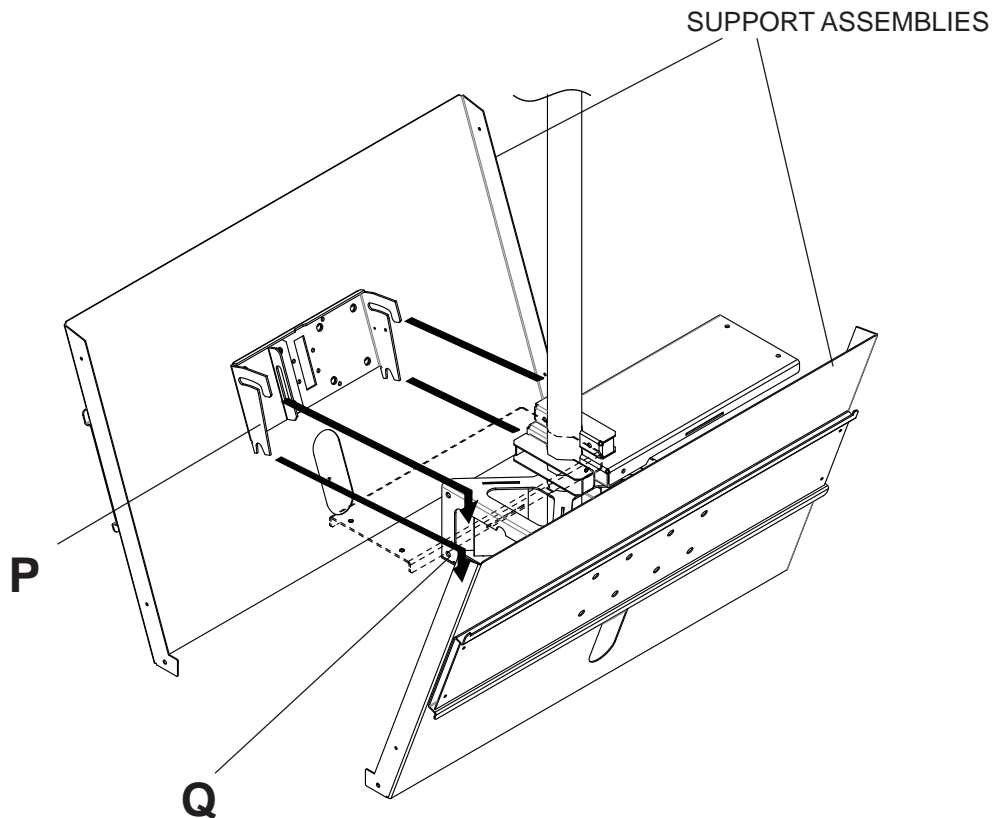

- 6 Run cable assembly (J) down through extension column around and through two cable brackets (K) as shown below.
Secure cable to itself using u-bolt, clamp and nuts from cable wire clamp (J).

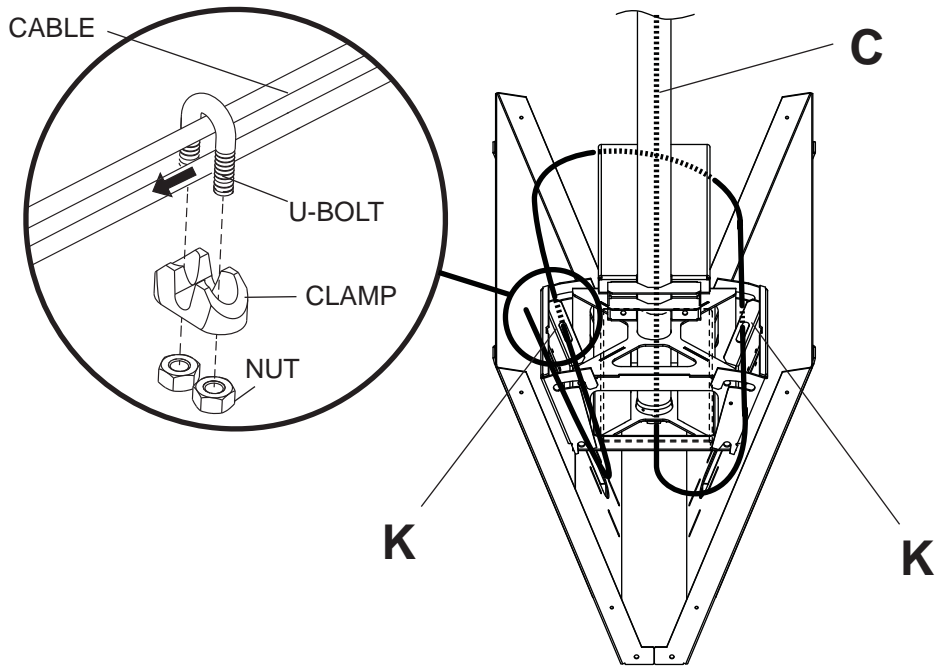

- 7 Secure bottom bracket (F) to support assemblies using M5 x 10 mm socket pin Type F screws (H) as shown below.

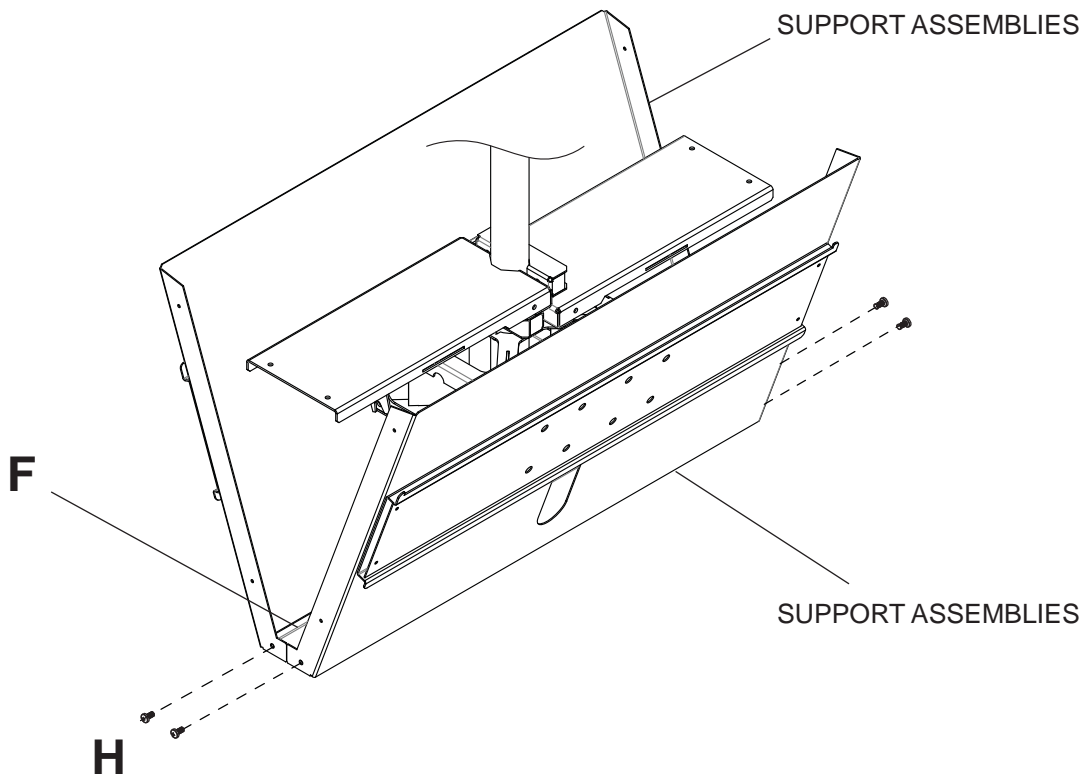

Installing Adapter Brackets

⚠ WARNING

- Tighten screws so adapter brackets are firmly attached. Do not tighten with excessive force. Overtightening can cause stress damage to screws, greatly reducing their holding power and possibly causing screw heads to become detached. Tighten to 40 in. • lb (4.5 N.M.) maximum torque.
- If screws don't get three complete turns in the screen inserts or if screws bottom out and bracket is still not tightly secured, damage may occur to screen or product may fail.

8 To prevent scratching the screen, set a cloth on a flat, level surface that will support the weight of the screen. Place screen face side down. If screen has knobs on the back, remove them to allow the adapter brackets to be attached. Place adapter brackets (**D**) on back of screen, align to holes, and center on back of screen as shown below. Attach the adapter brackets to the back of the screen using the appropriate combination of screws, multi-washers and spacers as shown in step 8-1 and step 8-2.

NOTE: Top and bottom holes on screen must always be used.

Verify that all holes are properly aligned, and then tighten screws using a phillips screwdriver.

NOTE: Tighten using security allen wrench (**X**).

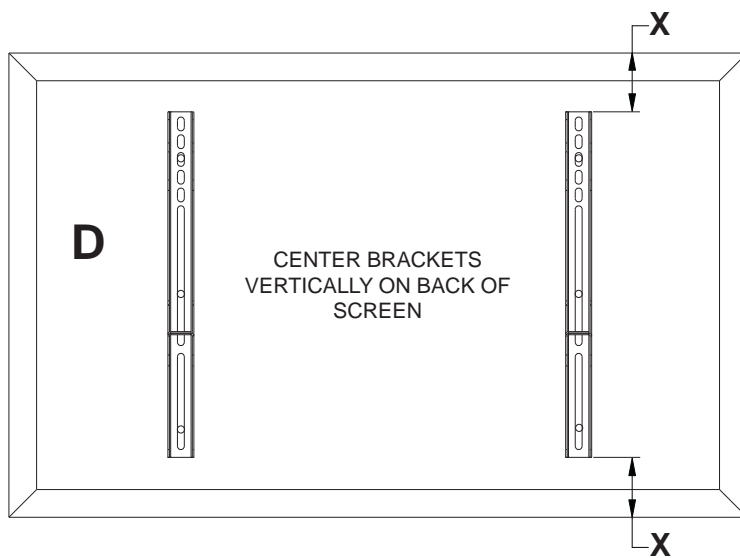

Note: "X" dimensions should be equal.

Notes:

- The number of fasteners used will vary, depending upon the type of screen.
- Multi-washers and spacers may not be used, depending upon the type of screen.
- Use the corresponding hole in the multi-washer that matches your screw size as shown.

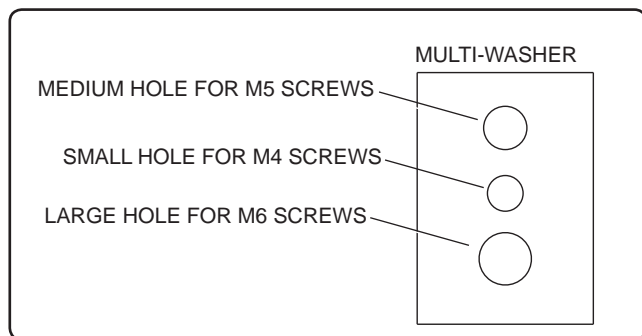

NOTE: For **flat back screens** proceed to step 8-1. For **bump-out or recessed back screen** skip to step 8-2.

For Flat Back Screen

- 8-1** Begin with the shortest length screw, hand thread through multi-washer and adapter bracket into screen as shown below. Screw must make at least three full turns into the mounting hole and fit snug into place. Do not over tighten. If screw cannot make three full turns into the screen, select a longer length screw from the baffled fastener pack. Repeat for remaining mounting holes, level brackets and tighten screws.

NOTE: Spacers may not be used, depending upon the type of screen.

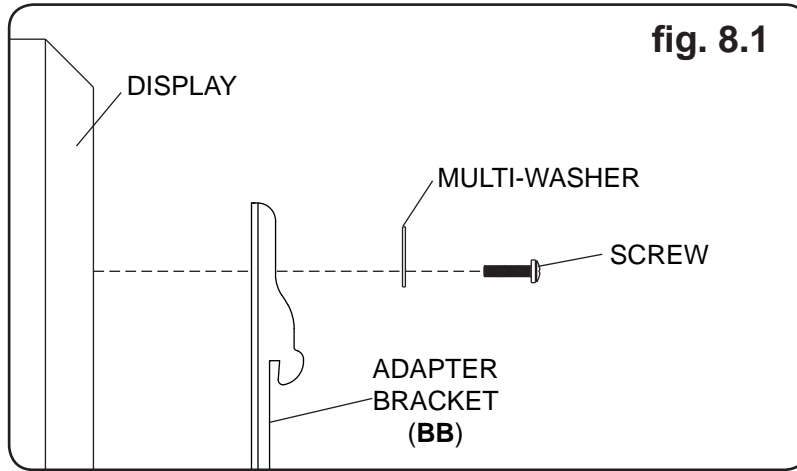

If you have any questions, please call Peerless customer care at **1-800-865-2112**.

For Bump-out or Recessed Back Screen

- 8-2** Begin with longer length screw, hand thread through multi-washer, adapter bracket and spacer in that order into screen as shown below. Screw must make at least three full turns into the mounting hole and fit snug into place. Do not over tighten. If screw cannot make three full turns into the screen, select a longer length screw from the baffled fastener pack. Repeat for remaining mounting holes, level brackets and tighten screws.

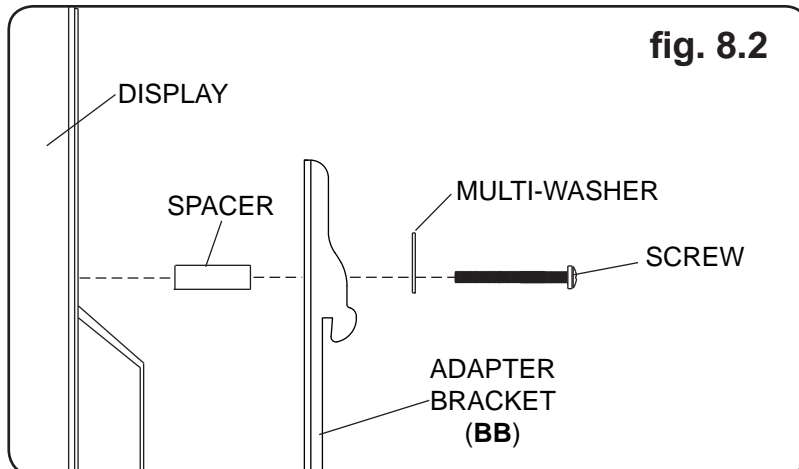

If you have any questions, please call Peerless customer care at **1-800-865-2112**.

Mounting and Removing Flat Panel Screen

⚠ WARNING

- Always use an assistant or mechanical lifting equipment to safely lift and position the plasma television.

9 Hook adapter brackets (**D**) onto adapter plate (**M**), then slowly swing screen in as shown. Turn safety/security screws clockwise at least six times to prevent screen from being removed as shown in detail 5. Tighten using wrench (**X**).

Screen can be adjusted horizontally if desired as shown in figure 9.1.

NOTE: To lock the screen down, tighten safety/security screws to adapter bracket as shown in detail 5.

To remove screen from mount, loosen safety/security screws, swing screen away from mount, and lift screen off of mount.

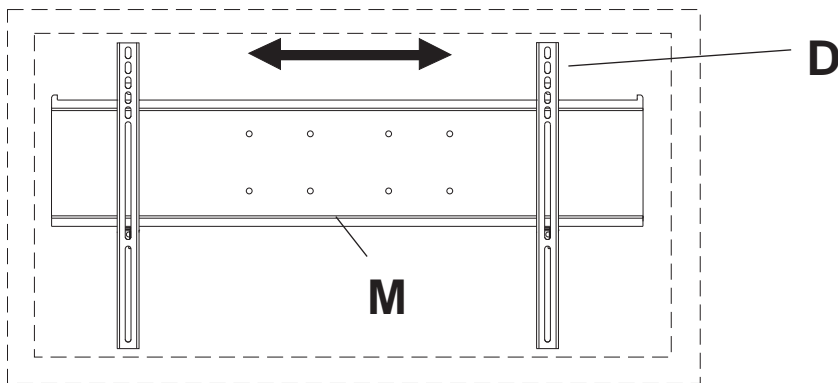
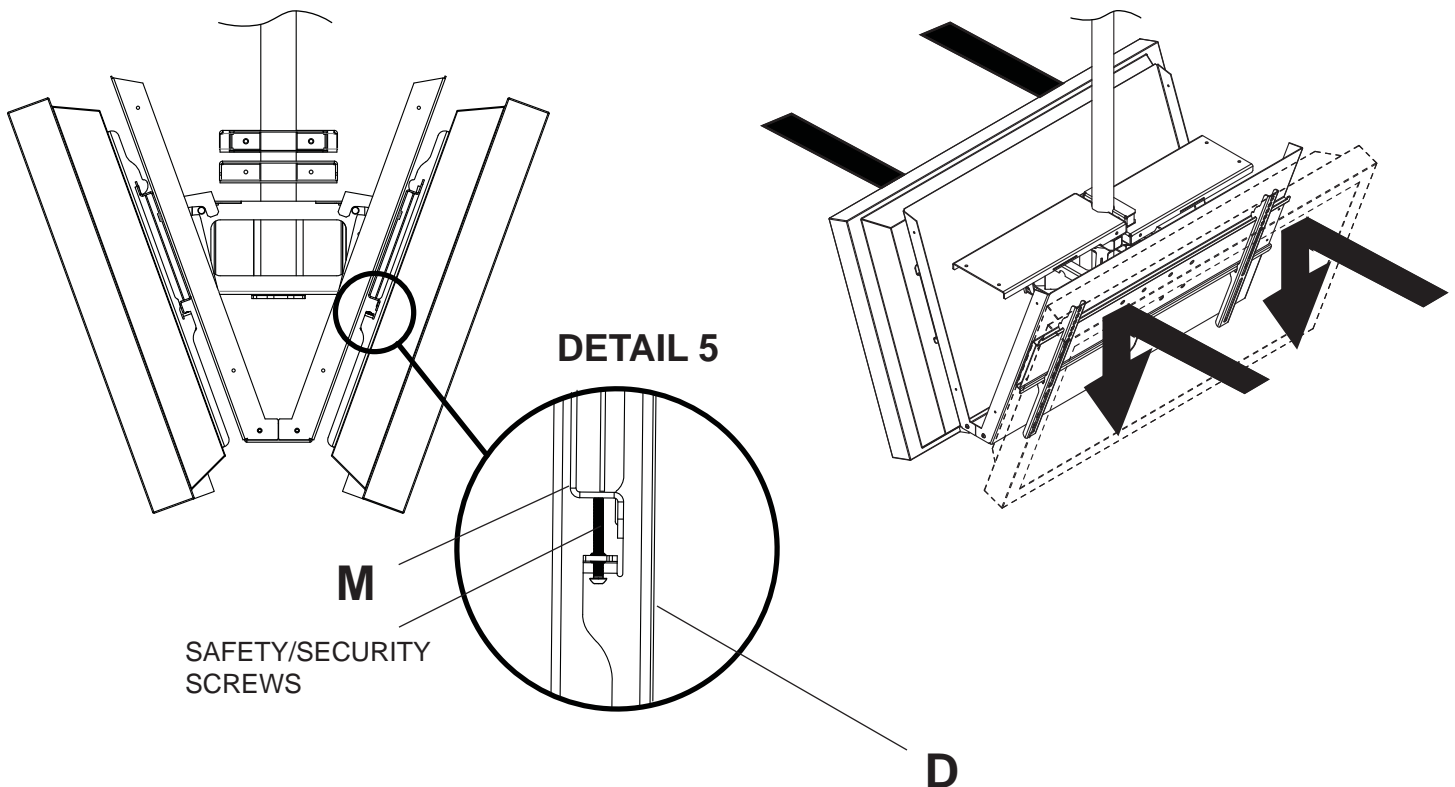
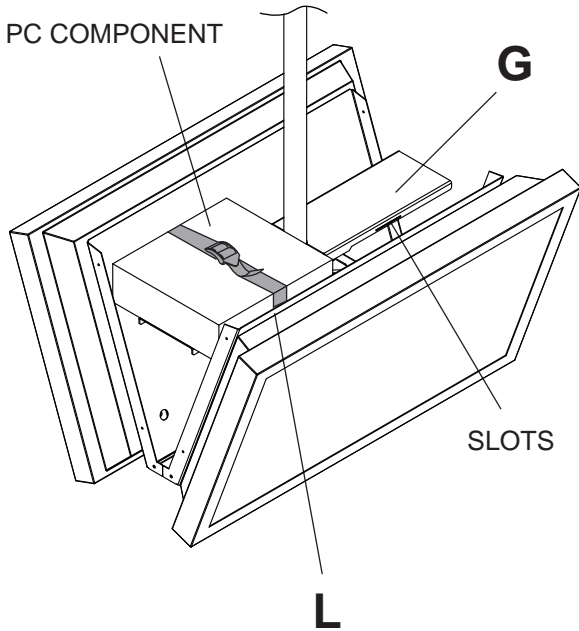

Fig. 9.1



10 Secure PC component to component shelf (**G**) with safety belt (**L**) through slots on component shelf (**G**) using instructions provided with safety belt.



11 Thread four M5 x 10 mm socket pin Type F screws (**H**) into support assemblies leaving 1/8" of exposed thread. Repeat with second side.

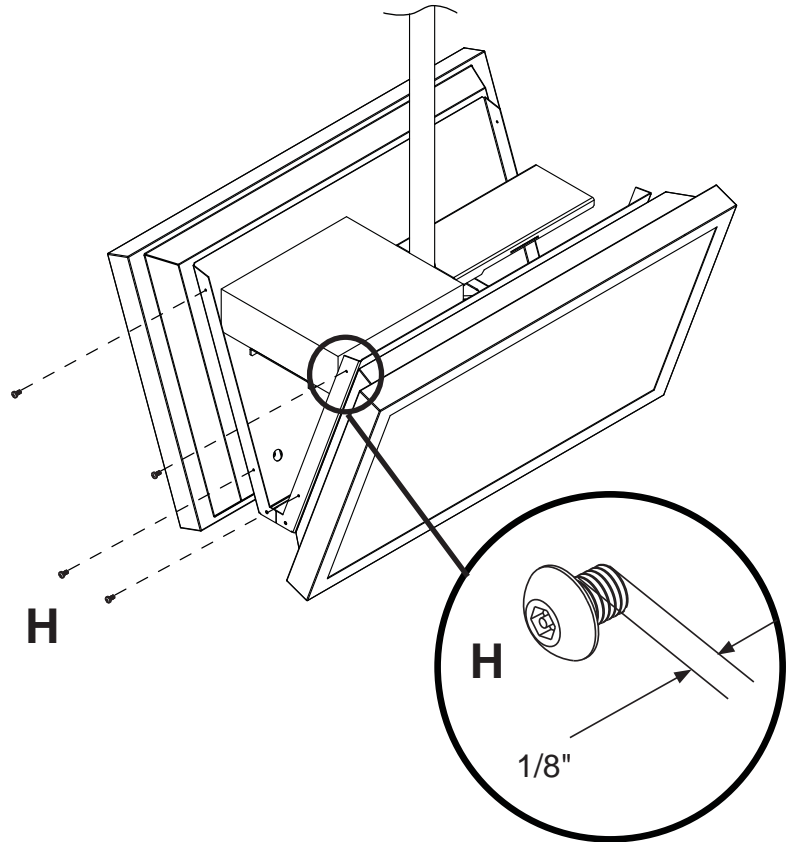

12 Hook side cover (**B**) keyholes onto exposed screws. Tighten all M5 x 10 mm socket pin Type F screws (**H**). Repeat with second side cover.

