

EPA762PU



Display size
42-75"



Max load
150lb (68kg)

Outdoor Articulating Wall Mount

FOR 42" TO 75" INDOOR OR OUTDOOR DISPLAYS

Peerless-AV's Outdoor Articulating Wall Mount is the ideal mounting solution for 42"-75" indoor or outdoor displays. The EPA762PU is specially coated with a protective anti-corrosive e-coating that repels against damaging temperature-related and outdoor corrosive elements. This all-season mounting solution is ideal for patios or decks, as well as installations in humid indoor areas like sun-rooms, locker rooms, bathrooms, car washes, indoor pools or water parks.

The EPA762PU is fully protected from all outdoor elements with a corrosion-resistant coating.

Additional Features

- ✓ Made of corrosion-resistant materials for weather resistance
- ✓ Fits displays with mounting patterns up to 730 x 405mm (28.75"W x 15.95"H) and up to 600 x 400mm VESA® compliant
- ✓ Universal model extends from 4.50" (114mm) to 22.72" (577mm) from the wall
- ✓ Open wall plate design for increased wall access and improved aesthetic
- ✓ Universal mounting pattern accommodates a variety of display mounting patterns
- ✓ IncreLok™ tilt allows adjustment of +15°/-5°
- ✓ Wood, concrete and cinder block mounting hardware included
- ✓ Includes all necessary wall and display attachment hardware

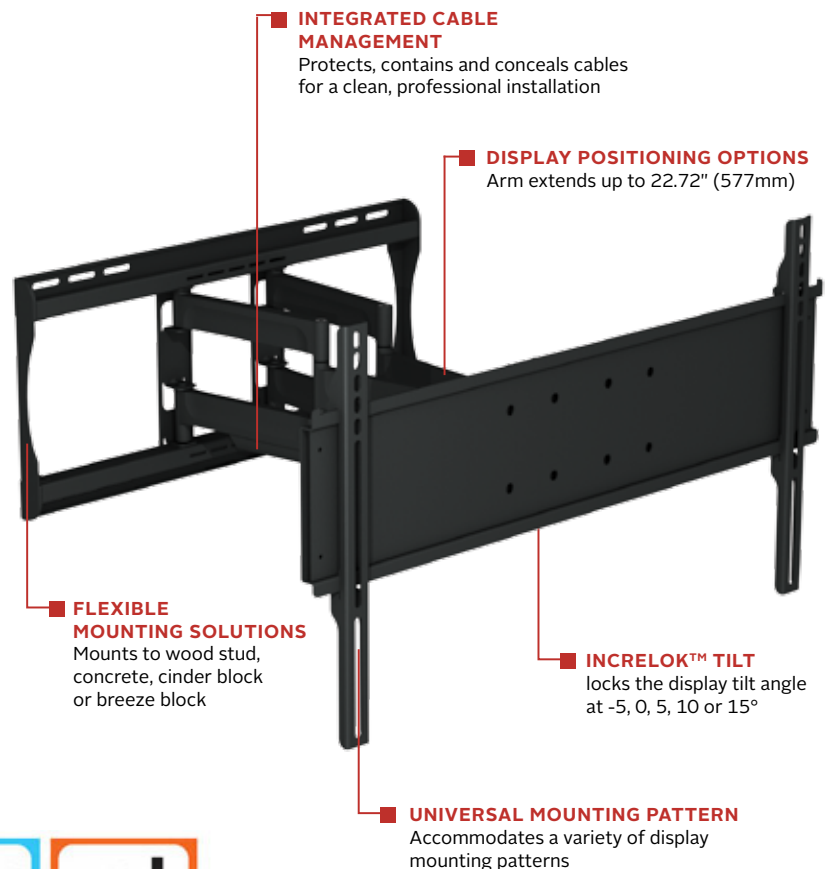

Touchboards

205 Westwood Ave, Long Branch, NJ 07740
Phone: 866-94 BOARDS (26273) / (732)-222-1511
Fax: (732)-222-7088 | E-mail: sales@touchboards.com



RoHS
2002/95/EC

EPA762PU Outdoor Articulating Wall Mount for 42" to 75" Indoor or Outdoor Displays

Product Specifications

	DIMENSIONS (W x H x D)	PRODUCT WEIGHT	LOAD CAPACITY	FINISH	AVAILABLE COLORS
EPA762PU	30.75" x 16.89" x 4.50"-22.72" (781 x 429 x 114-577mm)	26.8lb (12.2kg)	150lb (68.kg)	E-Coat Covered with Outdoor Powder Paint	Black

Package Specifications

	PACKAGE SIZE (W x H x D)	PACKAGE SHIP WEIGHT	PACKAGE UPC CODE	PACKAGE CONTENTS	UNITS IN PACKAGE
EPA762PU	33.00" x 4.25" x 12.00" (838 x 108 x 305mm)	29.3lb (13.3kg)	735029314387	Mount and Mounting Hardware	1

Accessories

HDS-OWK-200: Wireless Outdoor Kit
HDS-OWRE-200: Wireless Outdoor Module

Compatible with

CL models: Xtreme™ Outdoor Displays
UV models: UltraView™ Outdoor TVs

All dimensions = inch (mm)

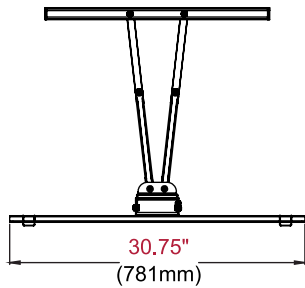

TOP VIEW

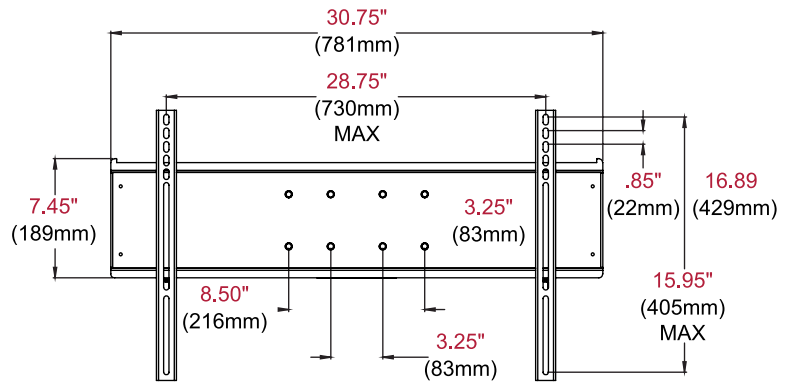

ADAPTOR DETAIL

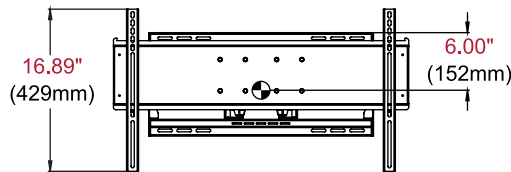

FRONT VIEW

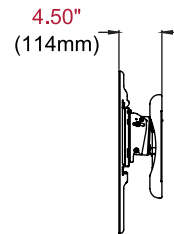

SIDE VIEW COLLAPSED

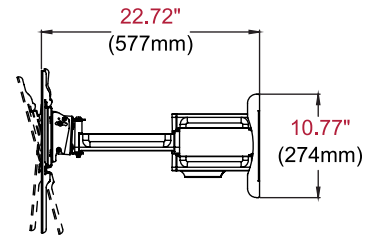

**SIDE VIEW EXTENDED
+15°/-5° TILT**

Architect Specifications

The Outdoor Articulating Wall Mount shall be a Peerless-AV model EPA762PU and shall be located where indicated on the plans. Assembly and installation shall be done according to instructions provided by the manufacturer.

Visit peerless-av.com to see the complete line of AV solutions from Peerless-AV, including outdoor displays, wireless, kiosks, digital audio, display mounts, projector mounts, carts/stands, and a full assortment of accessories.

Peerless-AV
 2300 White Oak Circle
 Aurora, IL 60502 USA
(800) 865-2112
(630) 375-5100
Fax: (800) 359-6500

Peerless-AV Europe
 Unit 3 Watford Interchange
 Colonial Way, Watford
 Herts, WD24 4WP
 United Kingdom
+44 (0) 1923 200100
Fax: +44 (0) 1923 200101

Peerless-AV de México
 Ave de las Industrias 413
 Parque Industrial Escobedo
 Escobedo, N.L.,
 Mexico 66050
+52 (81) 8384-8300
Fax: +52 (81) 8384-8360

