

HDS-OWRE-300



peerAir™ | PRO

Touchboards

205 Westwood Ave, Long Branch, NJ 07740
Phone: 866-94 BOARDS (26273) / (732)-222-1511
Fax: (732)-222-7088 | E-mail: sales@touchboards.com

Wireless Outdoor Integration Module

For Use With PeerAir™ Pro Wireless AV Multi-Display System

The PeerAir™ Pro Outdoor Weather Resistant Enclosure provides safe placement of AV and electrical components from rain, snow, splashing water and debris. Designed for optimum flexibility, the enclosure is ideal for use with the Peerless-AV® PeerAir™ Pro Wireless AV Multi-Display System, as well as other AV devices. Its internal power management support consolidates up to three power cords into one extension cable for a clean, clutter free installation.

Additional Features

- ✓ Safeguards AV and electrical components from elements such as rain, snow, splashing water and debris
- ✓ Built-in 3-tap grounded outlet for wireless components and display power allowing for only one power cable to be routed to the power outlet
- ✓ Ventilation portals for ideal air flow
- ✓ Provides excess display power and component cable storage for a clean look
- ✓ Accommodates installation to virtually any Peerless-AV® mount or flat surface
- ✓ Designed to support PeerAir™ Pro Wireless AV Multi-Display System as well as other AV devices
- ✓ Comes with a cam lock for secure installation
- ✓ Enclosure is constructed from flame resistant ABS Plastic (UL 94HB) material
- ✓ Ships pre-assembled
- ✓ Quick and easy installation

The PeerAir™ Pro Wireless Outdoor Integration Module protects against rain, snow, splashing water and debris.

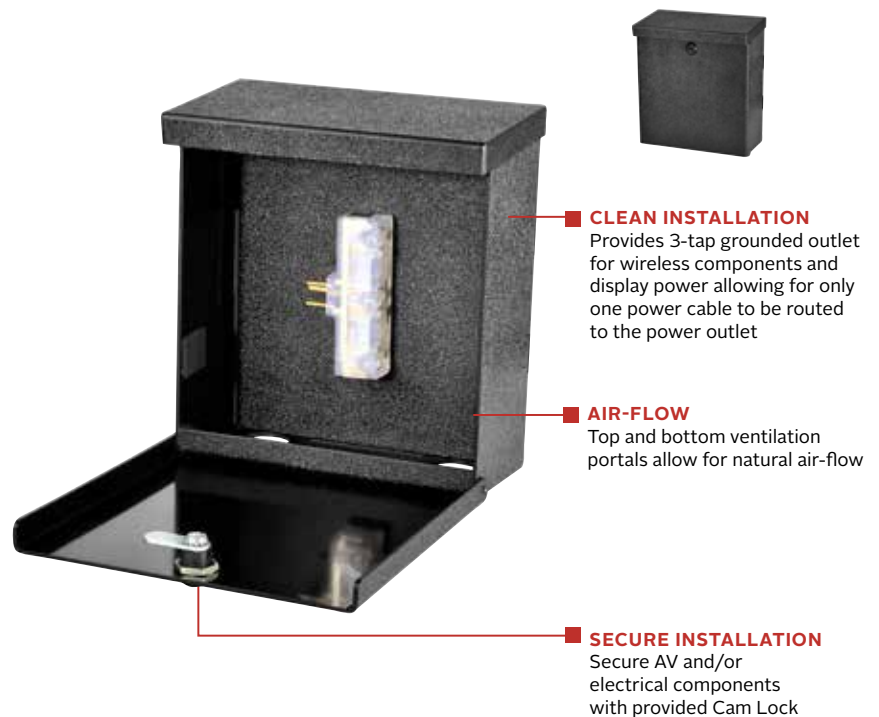

Cable management portals for a clean, clutter free installation



Includes cam lock to secure internal components



Adjustable mounting brackets easily attach the enclosure to virtually any Peerless-AV® mount or flat surface

HDS-OWRE-300	PeerAir™ Pro Wireless Outdoor Integration Module for use with PeerAir™ Pro Wireless AV Multi-Display System
---------------------	---

Product Specifications

	DIMENSIONS (W x H x D)	PRODUCT WEIGHT	FINISH	AVAILABLE COLORS
HDS-OWRE-300	8.32" x 9.12" x 4.34" (211 x 232 x 110mm)	3.85lb (1.75kg)	Textured ABS Plastic (UL 94HB)	Black

Package Specifications

	PACKAGE SIZE (W x H x D)	PACKAGE SHIP WEIGHT	PACKAGE UPC CODE	PACKAGE CONTENTS	UNITS IN PACKAGE
HDS-OWRE-300	10.00" x 10.00" x 8.00" (254 x 254 x 203.2mm)	4.85lb (2.20kg)	735029310532	<ul style="list-style-type: none"> Outdoor Weather Resistant Enclosure 4 x Mounting Brackets (2 short, 2 long) 3-Tap Grounded Outlet Removable Sub-Panel Mounting Hardware Instruction Manual 	1

Accessories

- HDS300:** PeerAir™ Pro Wireless AV Multi-Display System
- EPT650:** Wireless Outdoor Tilt Wall Mount for 32"-75" displays
- ESA763PU:** Wireless Outdoor Articulating Wall Mount for 32"-80" displays
- ACC-CMS-4F:** 4ft Cable Management
- EC-HD015F:** 1.5ft (.5m) High Speed HDMI Cable with Ethernet
- EC-HD025F:** 2.5ft (.75m) High Speed HDMI Cable with Ethernet
- EC-HD03F:** 3ft (1m) High Speed HDMI Cable with Ethernet
- CL-SCG200:** Screen Cleaning Gel

All dimensions = inch (mm)

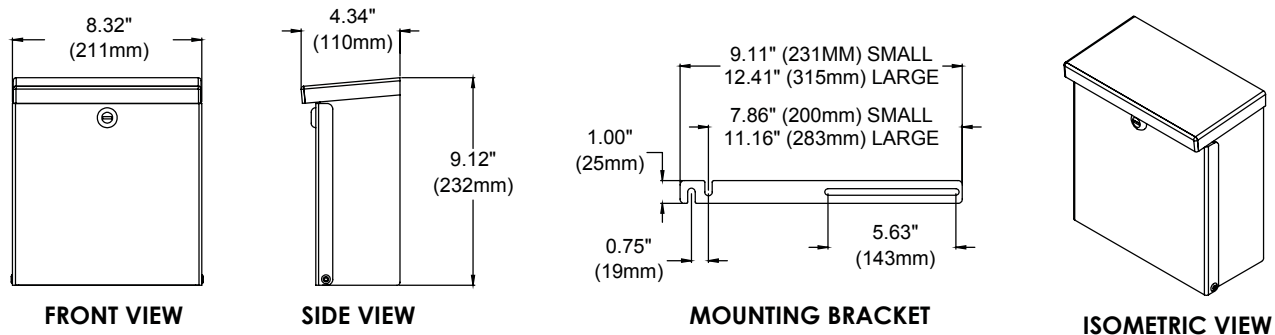

Architect Specifications

The PeerAir™ Pro Wireless Outdoor Integration Module shall be a Peerless-AV model HDS-OWRE-300 and shall be located where indicated on the plans. Assembly and installation shall be done according to instructions provided by the manufacturer.

Visit peerless-av.com to see the complete line of AV solutions from Peerless-AV, including outdoor displays, wireless, kiosks, digital audio, display mounts, projector mounts, carts/stands, and a full assortment of accessories.

Peerless-AV
2300 White Oak Circle
Aurora, IL 60502 USA
(800) 865-2112
(630) 375-5100
Fax: (800) 359-6500

Peerless-AV Europe
Unit 3 Watford Interchange
Colonial Way, Watford
Herts, WD24 4WP
United Kingdom
+44 (0) 1923 200100
Fax: +44 (0) 1923 200101

Peerless-AV de México
Ave de las Industrias 413
Parque Industrial Escobedo
Escobedo, N.L.,
Mexico 66050
+52 (81) 8384-8300
Fax: +52 (81) 8384-8360

