

MOD-FW2KIT300(-B)



Display size
46"-90"



Max load
211lb (96kg)
per display

Modular Series Dual Pole Floor-to-Wall Kit

FOR 46" TO 90" DISPLAYS

Peerless-AV's Modular Mount Series features a full range of products to fulfill multiple requirements with a limited number of components. The universality of the components allows you to configure your own perfect custom flat-panel display or projector mounting solution for any application. The Modular Mount Series was developed with the professional AV installer in mind with a 2" (50mm) diameter support pole that can be easily cut to length on the job site making it ideal for new projects as well as for upgrading existing installations. The MOD-FW2KIT300(-B) Floor-to-Wall mount kit helps eliminate guesswork, so you can create the perfect installation.

The universal design of the MOD-FW2KIT300(-B) allows you to configure your desired application just the way you want it, making a perfect installation possible.



Additional Features

- ✓ Kit includes:
 - Floor plate
 - Wall plate
 - Two 118" (3m) extension poles
 - Single display mount
 - Display stacking clamp
 - Large universal adaptor
- ✓ Heavy-duty floor plate securely mounts to wood or concrete floors and the wall plate works with wood, concrete, cinder block or breeze block wall structures
- ✓ Universal display adaptor for 46" to 90" displays with VESA® mounting patterns up to 600 x 400mm
- ✓ Display can be positioned at any point along the height of the poles
- ✓ Modular design allows additional displays to be stacked on the dual poles

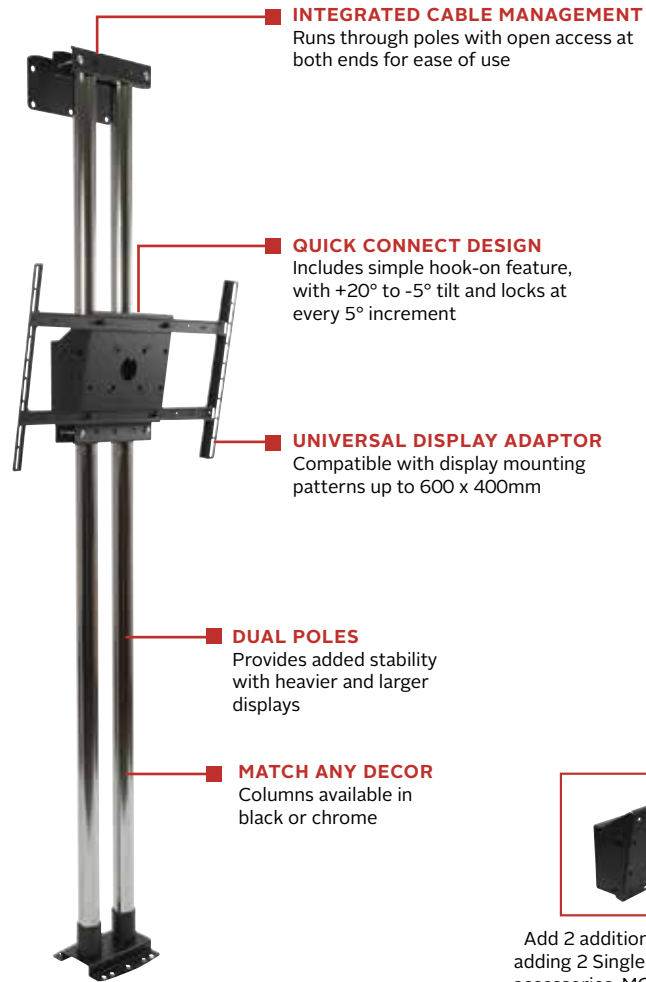

Add 2 additional displays by adding 2 Single Display Mount accessories, MOD-FPMS2 and Stacking Clamps, MOD-ASC2. (MOD-UNL2 may be required)

Touchboards

205 Westwood Ave, Long Branch, NJ 07740
Phone: 866-94 BOARDS (26273) / (732)-222-1511
Fax: (732)-222-7088 | E-mail: sales@touchboards.com



info@peerless-av.com
peerless-av.com

peerless-AV®

Model Number

WARRANTY: Limited 5-year

MOD-FW2KIT300(-B) Modular Series Dual Pole Floor-to-Wall Kit for 46" to 90" Displays

Product Specifications

	DIMENSIONS (W x H x D)	PRODUCT WEIGHT	LOAD CAPACITY	FINISH	AVAILABLE COLORS
MOD-FW2KIT300(-B)	24.57" x 119.43" x 7.48" (624 x 3034 x 190mm)	51.1lb (23.2kg)	211lb (96kg) per display. For multi screen applications the max system load is 411lb (192kg) with a maximum of 3 displays positioned on one side of the poles.	Powder Coat or Chrome	MOD-FW2KIT300: Black with chrome poles MOD-FW2KIT300-B: Black with black poles

Package Specifications

	PACKAGE SIZE (W x H x D)	PACKAGE SHIP WEIGHT	PACKAGE UPC CODE	PACKAGE CONTENTS	UNITS IN PACKAGE
MOD-FW2KIT300(-B)	BOX1: 38.50" x 12.25" x 8.50" (978 x 311 x 216mm) BOX 2 & 3: 120.00" x 2.50" x 2.50" (3048 x 64 x 64mm)	29.5lb (13.4kg) 14.8lb (6.7kg) each	MOD-FW2KIT300: 735029301783 MOD-FW2KIT300-B: 735029301790	MOD-CPF2, MOD-WP2, MOD-FPMS2, MOD-UNL2, MOD-ASC2, (2) MOD-P300, Mounting hardware & instructions	1

Accessories

MOD-ACF2: Dual Pole Cosmetic Cover
MOD-FPMS2: Dual Pole Single Display Mount
MOD-ASC2: Dual Pole Display Mount Stacking Clamp

MOD-UNL2: Large Universal Adaptor
ACC925: Security Fastener Pack

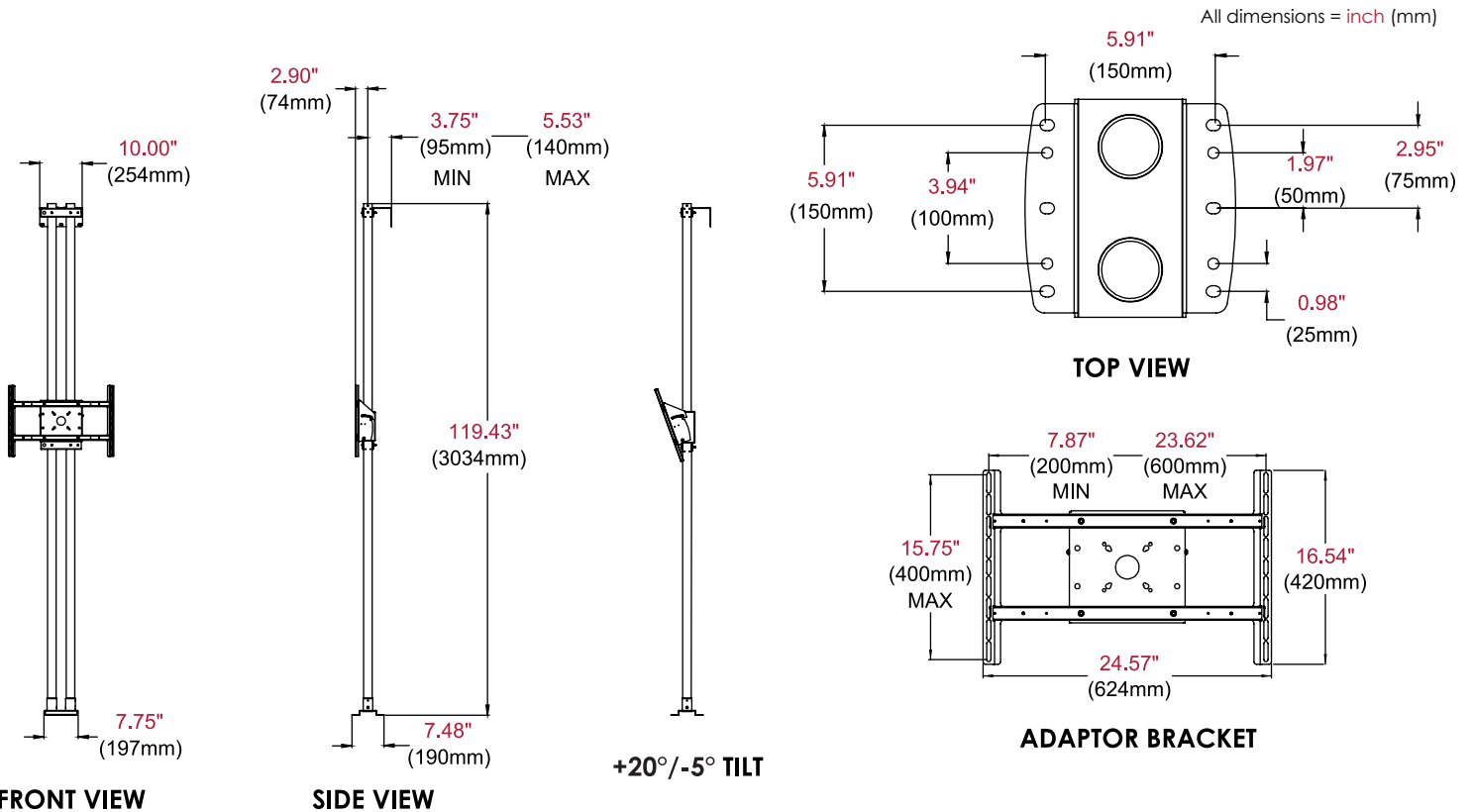

Architect Specifications

The Modular Series Dual Pole Floor-to-Wall Kit shall be a Peerless-AV model MOD-FW2KIT300(-B) and shall be located where indicated on the plans. Assembly and installation shall be done according to instructions provided by the manufacturer.

Visit peerless-av.com to see the complete line of AV solutions from Peerless-AV, including outdoor displays, wireless, kiosks, digital audio, display mounts, projector mounts, carts/stands, and a full assortment of accessories.

Peerless-AV
 2300 White Oak Circle
 Aurora, IL 60502 USA
(800) 865-2112
(630) 375-5100
Fax: (800) 359-6500

Peerless-AV Europe
 Unit 3 Watford Interchange
 Colonial Way, Watford
 Herts, WD24 4WP
 United Kingdom
+44 (0) 1923 200100
Fax: +44 (0) 1923 200101

Peerless-AV de México
 Ave de las Industrias 413
 Parque Industrial Escobedo
 Escobedo, N.L.,
 Mexico 66050
+52 (81) 8384-8300
Fax: +52 (81) 8384-8360

