



OmniControl 200, rack unit with integrated power supply pack



Similar Image

OmniControl 200, rack unit with integrated power supply pack

- Universal control device for all products with Pfeiffer Vacuum RS-485-Protocol
- Easy operation via 3.5" touch display
- Uncomplicated data collection and processing between the Pfeiffer Vacuum devices
- The respective modules define the scope of functions

Dimensions

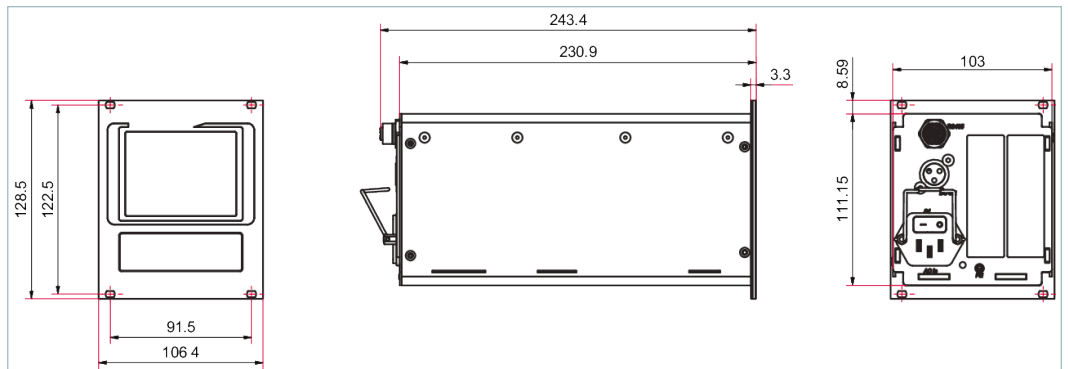

Technical Data	OmniControl 200, rack unit with integrated power supply pack
Ambient temperature	0-50 °C 32-122 °F 273-323 K
Mains connection	100 – 240 V AC ±10 %
Mains connection: frequency (range)	47 – 63 Hz
Mains connection: power consumption	300 W
Measuring channel	1 Pcs.
Module Slot 2	Gauge/IO
Output current	11.4 A
Output voltage	24 V DC
Power consumption max.	300 W
Protection degree	IP20
Weight	2.1 kg 4.63 lb

Order number	
OmniControl 200	PE D50 100 0

Accessories	
Adapters (electrical) RS-232/485	
Y-connector M12 for RS-485	P 4723 010
Cables Analog/relay cables	
Measurement cable DigiLine xPT 200 AR/CCT 3xx AR to TPG 3xx, 3 m	PT 348 250 -T
Cables Backing pump control cables	
Connection cable MVP-TC-TPS, 3 m	PE 100 013 -T
Cables Connection cables	
Connection cable, angled, with RS-485 interface and two accessory ports from TC 80/110/120 to power supply pack, 1 m	PM 071 655 -T
Connection cable for HiPace with TC 400/TM 700 to power supply pack TPS/DCU 310/311/400/401	PM 061 352 -T
Cables Mains cables / Power cords	
Mains cable 230 V AC, CEE 7/7 to C13, 3 m	P 4564 309 ZA
Mains cable 115 V AC, NEMA 5-15 to C13, 3 m	P 4564 309 ZE
Mains cable 208 V AC, NEMA 6-15 to C13, 3 m	P 4564 309 ZF
Cables RS-485 Interface cables	
Interface cable, M12 m straight / M12 m straight, 3 m	PM 061 283 -T
Monitoring Pressure Sensors	
Measurement cable, 3 m	PT 448 250 -T

VACUUM SOLUTIONS FROM A SINGLE SOURCE

Pfeiffer Vacuum stands for innovative and custom vacuum solutions worldwide, technological perfection, competent advice and reliable service.

COMPLETE RANGE OF PRODUCTS

From a single component to complex systems:

We are the only supplier of vacuum technology that provides a complete product portfolio.

COMPETENCE IN THEORY AND PRACTICE

Benefit from our know-how and our portfolio of training opportunities!

We support you with your plant layout and provide first-class on-site service worldwide.

Are you looking for a
perfect vacuum solution?
Please contact us:

Pfeiffer Vacuum GmbH
Headquarters · Germany
T +49 6441 802-0
info@pfeiffer-vacuum.de

www.pfeiffer-vacuum.com

All data subject to change without prior notice.

PFEIFFER  **VACUUM**