

USER'S MANUAL



AC DIELECTRIC TEST SET
600 Series

Model Number 6CP120/60-10

Version 1.1

\

Phenix Technologies, Inc.
75 Speicher Drive
Accident, Maryland 21520

Rev 5/28/2015
nab

6CP120/60-10

TABLE OF CONTENTS

<u>DESCRIPTION</u>	<u>SECTION NUMBER</u>
DANGER / GENERAL SAFETY PRECAUTIONS	
TECHNICAL SPECIFICATIONS	1
UNCRATING PROCEDURE	2
CONTROLS AND INDICATORS	3
INITIAL SET-UP—MECHANICAL / ELECTRICAL	4
OPERATIONAL VERIFICATION / GENERAL TEST	5
CALIBRATION	6
TROUBLESHOOTING	7
MECHANICAL MAINTENANCE	8
CHECKING OIL PURITY / SPECIFICATIONS	9
TRANSPORTING / STORAGE OF EQUIPMENT	10
CIRCUIT DIAGRAM SYMBOLS	11
ELECTRICAL DIAGRAMS	12
PARTS ORDERING INFORMATION	13
RECOMMENDED SPARE PARTS	14
PARTS LIST	15
RETURNED MATERIAL	16
CUSTOMER COMMENTS / SUGGESTIONS	17
ATTACHMENTS	
PTC-13 TIMER MANUAL	

GENERAL SAFETY PRECAUTIONS



CAUTION

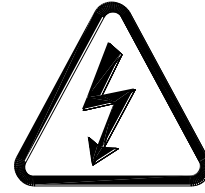

HIGH VOLTAGE

This equipment is capable of providing POTENTIALLY LETHAL VOLTAGES! Improper operation or test practices may result in injury or death to the operator or surrounding personnel.

The operation of High Voltage test equipment should only be performed by personnel familiar with HIGH VOLTAGE testing and safety procedures. The operator of this equipment must be aware of all hazards associated with High Voltage testing. The operator is responsible for himself and others in close proximity of the testing area.

Some General Safety Practices for working with High Voltage Test Equipment have been listed below for your reference.

- **Become familiar with your instrument before performing an actual test**
- **Know your work area, check that all circuits are de-energized and locked out.**
- **Never work alone; always work with another qualified worker.**
- **Mark off entire work area with barriers and warning tape.**
- **Make all personnel aware of your testing activities.**
- **Be aware of dangerous conditions that may arise from energizing a test specimen.**
- **Never modify test equipment, modifications to equipment could introduce an unknown hazard or hinder a designed-in safety feature.**
- **DO NOT operate damaged equipment. Remove power, and do not use the equipment until safe operation can be verified by service-trained personnel.**

Phenix Technologies, Inc. assumes no liability for unsafe or improper use of test equipment.

SECTION 1: TECHNICAL SPECIFICATIONS

Input

220 - 240 volts, single phase, 50/60 Hz, 30 amperes

Output Rating

0 - 60 kilovolts, 166 milliamperes

0 - 120 kilovolts, 83 milliamperes

Duty Cycle – Capacitive Loading

5 minutes ON / 15 minutes OFF @ 10 kVA

15 minutes ON / 1 hour OFF @ 7.5kVA

1 hour ON / 1 hour OFF @ 5 kVA

Type of Cooling

ONAN (Oil / Air Natural Convection)

Operating Ambient Temperature

10 – 40 degrees C

Output Termination

2" Polished Ball – 60 kV

3" x 12" High Voltage Spinning – 120 kV

Metering - Digital

Output Voltmeter: 3 ½ Digit LCD, Accuracy $\pm(0.8\%$ of reading + 0.2% of range).

Output Currentmeter: 3 ½ Digit LCD, Accuracy $\pm(0.8\%$ of reading + 0.2% of range)

4 Ranges: 0-200 μ A, 2mA, 20mA, 200mA

Sizes and Weights

Control/Regulator Section: 21.25" (540mm) W x 16.75" (426mm) D x 13.75" (350mm) H;
63 lbs. (29 kg)

High Voltage Section: 19" (483mm) W x 19" (483mm) D x 29" (734mm) H;
280 lbs. (127 kg)

Additional Equipment

Cart: 22.5" (572mm) W x 29.25" (743mm) D x 50" (1270mm) H;
70 lbs. (32 kg)

Cables: 30 lbs. (14 kg)

SECTION 2: UNCRATING PROCEDURE

1. Exercise care in removing shipping materials so as not to damage unit.
2. Perform visual inspection to determine if unit was damaged during shipment. If there are any signs of physical damage (such as dents, scratches, oil leaks), contact the factory before proceeding.

SECTION 3: CONTROLS AND INDICATORS

Control Panel
Figure. 3-1

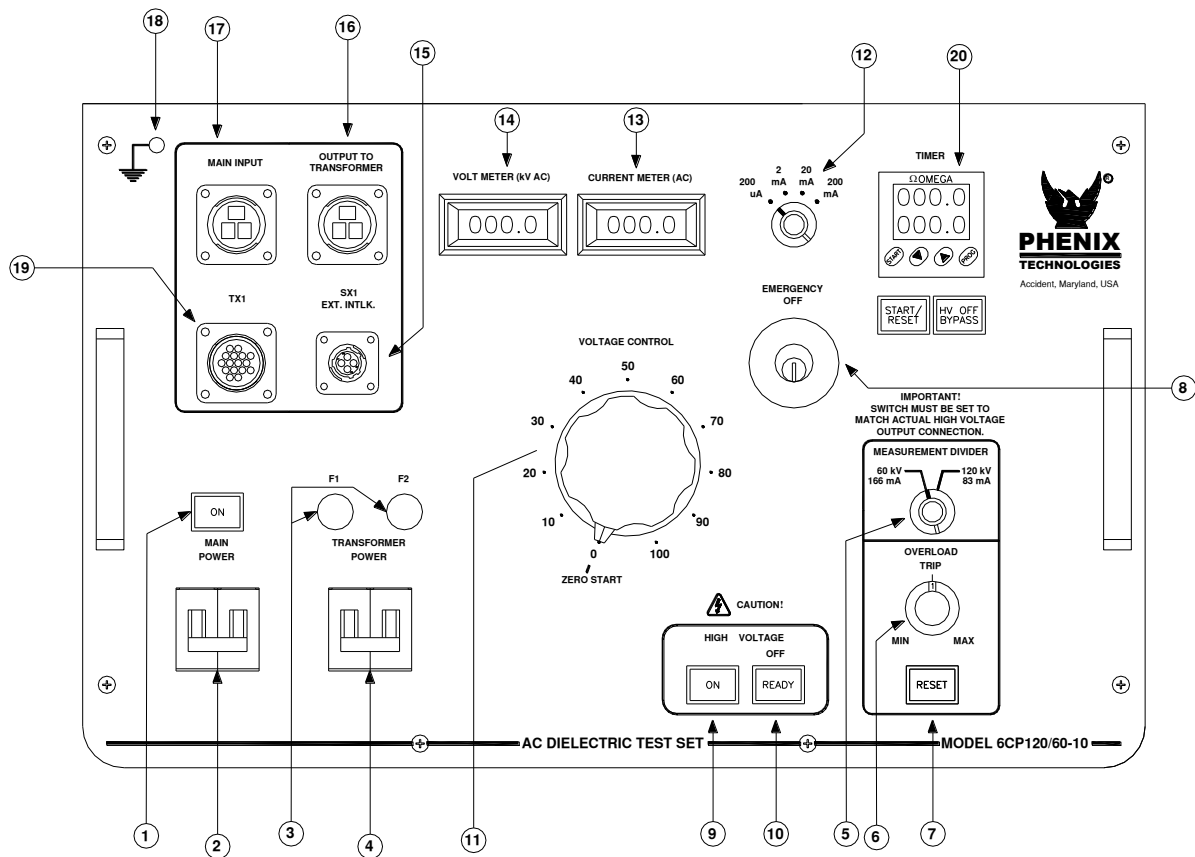

Descriptions are keyed to Figure 3-1:

1. **Main Power Indicator.**
2. **Main Power Circuit Breaker**
3. **F1, F2**
Control Power Fuse.
4. **Transformer Power Circuit Breaker**
5. **Measurement Divider Switch**
Selects proper overload and voltmeter circuitry for the H.V. output terminal being used. Match switch setting to output being used on HV transformer.
6. **Overload Trip**
Use for presetting desired Overcurrent trip setting. Range approximately 10-110% of rated current.

CONTROLS AND INDICATORS

CONTROL PANEL (cont'd)

7. **Reset**
Will light when Overcurrent trip setting is exceeded. Push to reset. Lamp must be extinguished for H.V. ON.
8. **Emergency Off**
Push down to stop test immediately. Button must be pulled up to activate High Voltage Output.
9. **High Voltage On Switch and Indicator Lamp**
Turns on H.V. when Ready indicator is illuminated.
10. **High Voltage Off Switch and Indicator Lamp**
Turns H.V. off, indicator shows when all conditions are met to turn H.V. ON. (External Interlock closed, Reset Lamp off, Emergency Off Button pulled up, Voltage Control at Zero).
11. **Voltage Control**
Adjusts Output Voltage and must be set at zero to turn High Voltage on.
12. **Currentmeter Range Selector**
13. **Output Currentmeter**
14. **Output Voltmeter**
15. **SX1 External Interlock**
Provides for user connection of external interlock or auxiliary safety control device such as Emergency Off Switch, Gate Switch, Footswitch, Dead man Switch, etc.
16. **Output to Transformer**
High Voltage Transformer power connection.
17. **Main Input**
Main input cable connects here.
18. **Ground Terminal**
19. **TX1**
Signal/ Metering cable between H.V. Unit and controls connects here.
20. **Timer**
Press START/RESET to start the timer after test voltage has been reached. Press START/RESET again to reset timer to the original setting. Press HV OFF BYPASS to allow high voltage to remain on after the timer has expired. Test time can be set using the buttons on the face of the timer.

CONTROLS AND INDICATORS

High Voltage Transformer

Figure 3-2

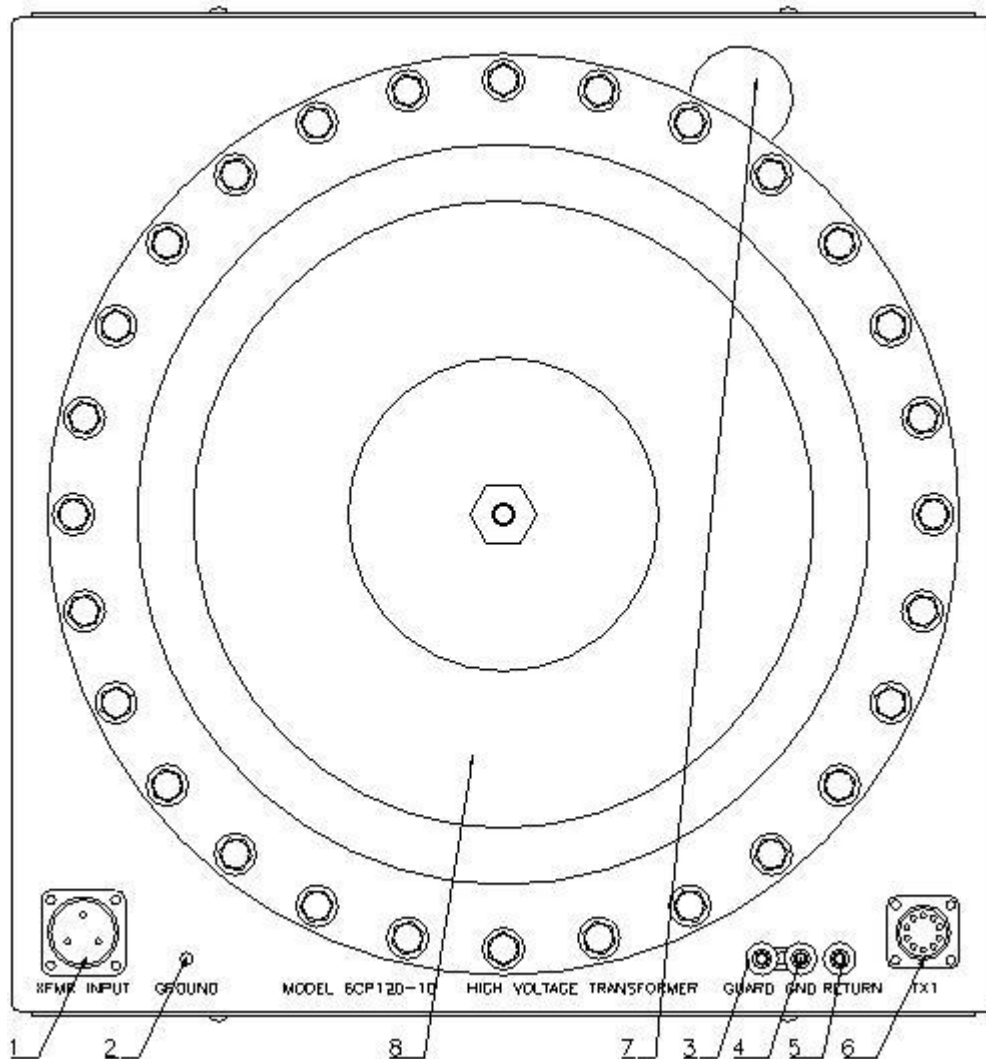

Descriptions are keyed to Figure 3-2:

1. **Power Connector**
Connect the Power Cable from 'Output to Transformer' connector on control box at this point.
2. **High Voltage Unit Ground Point**
A Ground cable from facility ground or earth ground **must** be connected here.
3. **Guard Binding Post (GRD)**
Currents associated with this connection bypass the current meter (meter bypass connection). See Section 5 for more information on these connections.
4. **Ground Binding Post with Jumper Clip (GND)** - This binding post is connected to ground. See Section 5 for more information on these connections.

NOTE: The Jumper Clip **must always** be connected from Ground to either Return or Guard.

CONTROLS AND INDICATORS

High Voltage Transformer (cont'd)

5. **Return Binding Post (RTN)**
Low potential side of test specimen connects here. This connection routes current through the Current Meter circuit (metered connection point).
6. **TX1 Connector**
Signal / Metering cable connects from here to TX1 on control box.
7. **60 kV TAP**
For 0 – 60 kV output at 0 – 166 mA – the Measurement Divider switch on the control panel must be set to 60 kV/166 mA position.
8. **120 kV Tap**
For 0 – 120 kV output at 0 – 83 mA - the Measurement Divider switch on the control panel must be set to 120 kV / 83 mA.

SECTION 4: INITIAL SET-UP--MECHANICAL

1. Set up object under test.
2. The area to be used for the test must provide sufficient mechanical and electrical clearances. The approximate weight of each section is available from the nameplates or the Specifications page.
3. If the unit is to be operated indoors, be sure the floor will be strong enough to support the unit.
If outdoor operation is to be used, the site for the base must be capable of supporting the unit without any settling that would tilt the assembly.
4. Position the High Voltage Transformer Tank and Control Unit as necessary for operation.
5. Clean entire High Voltage Unit with nothing stronger than ordinary household cleaner to remove all traces of any surface contamination. This cleaning should also include the High Voltage Electrodes.

INITIAL SET-UP--ELECTRICAL

WARNING

Ground the output of the High Voltage Transformer until set-up is complete! Be sure the Main Power Circuit Breaker is in the OFF position before proceeding. This equipment should only be operated by personnel familiar with High Voltage testing and safety procedures.

- Grounding Connections:
 - Tie ground post on control case to ground stud on high voltage cylinder base using copper braid or jacketed cable with current capacity equal to or greater than the input current.
 - Tie ground stud on the high voltage cylinder base to facility ground using copper braid or jacketed cable with current capacity equal to or greater than the input current.
- Select the Standard or Guard current metering configuration (See following pages for explanation).
- If the external interlock function is to be used, remove the jumper on the male cable end of the SX1 connector and connect the external security circuit at these points.

NOTE: The external interlock circuit must consist of a closed loop of dead contacts; an open circuit prevents the high voltage output from being energized. When the control power is on, the external circuit will be energized with 120 volts AC.
- Connect signal / metering cable between High Voltage Transformer TX1 connector and TX1 connector on the controls.
- Connect the power cable from the High Voltage Transformer to the 'Output to Transformer' connection on the control box.
- Connect the test object to the output termination of the high voltage transformer using supplied output cable. Insure that the ground connection is applicable for test level and type of test and that the connection has sufficient safety clearances for the voltage rating. Two high voltage output connections are possible:
 - 60kV, 166mA: The 60kV tap is located on the side of the high voltage cylinder. Set the Measurement Divider switch (See Section 4) to the 60 kV/166mA position when using this output. This sets the metering and overload properly for the output being used.
 - 120kV, 83mA: The 120kV tap is located on the top of the high voltage cylinder. Set the Measurement Divider switch (see Section 4) to the 120 kV/83mA position when using this output.

A wire can be used to make this connection; however, for best results (less corona leakage current), route a wire down the center of a one-inch diameter pipe (aluminum or copper) and solidly connect the ends of the wire to the output tap and the test specimen. The pipe should also be solidly connected at each end.
- Connect the input main power cable to the 'Main Input' connection at the control box and then to the facility power source.

INITIAL SET-UP--ELECTRICAL

CURRENT METER GUARD CIRCUIT:

There are three terminals on the base of the high voltage transformer; white GRD (Guard), green GND (Ground), and a red RTN (Return). There is a metal jumper that must always be connected between either the GND and GRD terminals or the GND and RTN terminals.

Refer to the figure on the next page:

Standard Mode

In this configuration, the current meter measures all leakage current from the high voltage electrode. Measured current includes specimen leakage and stray leakage.

Guard Mode

In this configuration, only the leakage current from the high voltage electrode through the test specimen to the RTN terminal is measured by the current meter. Any stray leakage current to ground is guarded out (bypasses the meter) and is not measured. Stray leakage current to ground can be from several sources. The high voltage transformer has some capacitive leakage to ground. The high voltage connection might have some leakage due to partial discharge (corona). The test specimen might have some leakage current to ground, and your application requires that this "stray" leakage not be measured.

Electrical Setup

In either configuration, the high voltage transformer's ground stud must always be connected to earth ground. The GND terminal referred in the following two paragraphs is internally connected to the ground stud.

For standard current measurement, connect the jumper between the GND and RTN terminals. Connect the test specimen return (low voltage side) to the RTN terminal.

For guarded current measurement, connect the jumper between the GND and GRD terminals. Connect the test specimen return (low voltage side) to the RTN terminal. Do not connect the specimen return to ground. The test specimen must be totally isolated from ground.

INITIAL SET-UP--ELECTRICAL

CURRENT METER GUARD CIRCUIT

Figure 4-1

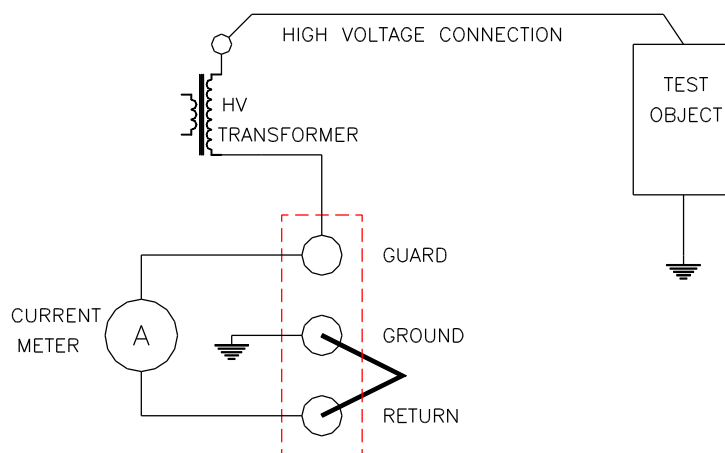

STANDARD MODE

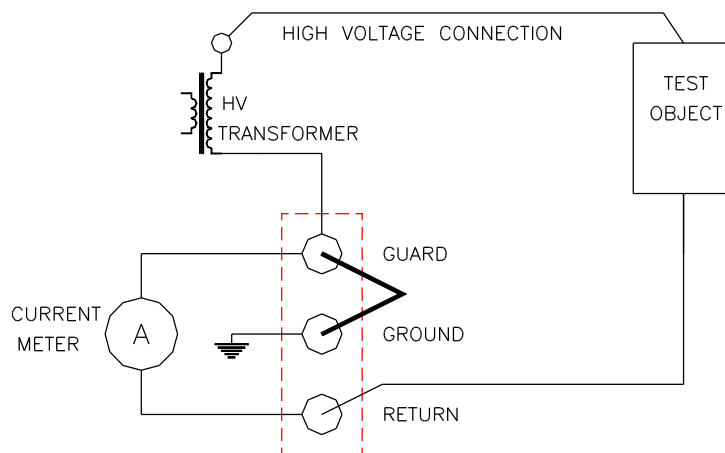

GUARD MODE

SECTION 5: OPERATIONAL VERIFICATION PROCEDURE

WARNING:

This equipment should only be used by personnel familiar with High Voltage Testing and Safety Procedures.

1. Make sure that Main Power Circuit Breaker on the Control Panel is in OFF position.
2. Make sure that all electrical connections have been properly made between the Controls and High Voltage Unit, including grounds. Remove Ground from HV Transformer output if it is grounded. There is to be no connection to the high voltage outputs at this time. There must be adequate clearance distance from the High Voltage Unit to allow voltage to be raised safely.
3. Place currentmeter in RTN mode. (Connect jumper of RTN/GND/GRD binding posts between RTN and GND.)
4. Connect Main Input Power Cable to Controls and to Power Source. Switch the Main Power Circuit Breaker on the Control Panel to On position. Main Power indicator lamp should illuminate. Check that the Transformer Power Breaker is on, Emergency Off button is pulled up, Voltage Control is at Zero, Reset Lamp is Off, and EXT INTLK CKT is complete or has shorting jumper in place. HV Off lamp should be illuminated.
5. Depress HV On switch. Indicator lamp should illuminate. Depress the HV Off switch. HV On indicator lamp should extinguish and HV Off / Ready lamp should illuminate.

NOTE: The following conditions **must be** met before High Voltage will engage: External Interlock loop must be closed; Emergency Off switch must be closed (mushroom button up), Overload Reset Lamp must be off, Voltage Control at Zero Start, and Transformer Power Circuit Breaker on.

6. Set Measurement Divider Switch to 120 kV / 83 mA
7. Press the HV On switch.
8. Manually raise the Voltage Control dial on the Control Panel to approximately 50 (50%). Voltmeter should indicate voltage change, and show approximately 54 to 66 kV.
9. Select 60 kV / 166 mA on Measurement Divider Selector Switch. At 50 on Voltage Control Dial, voltmeter should read approximately 27 to 33 kV.
10. Return Voltage Control to Zero. Press HV Off switch.
11. Turn Main Power Circuit Breaker off and connect a short between the 60kV High Voltage Output and Ground. Measurement Divider Switch is to be set at 60 kV / 166 mA.
12. Set Overcurrent Trip to low (1) setting.
13. Turn Main Power Circuit Breaker on. Press HV On switch and slowly raise voltage with the dial on the Control Panel. Output Current Meter will indicate [change??], and at approximately 10% of output current rating, the High Voltage will trip off and the Overcurrent Indicator Lamp will illuminate. With the front panel Overload Selector Switch set at 60 kV/166 mA, the trip point should be at approximately 17 mA. Return Voltage Control to zero and turn off Main Power Circuit breaker.

OPERATIONAL VERIFICATION PROCEDURE

OPERATIONAL VERIFICATION (cont'd)

14. Move short from 60 kV output to 120 kV output and ground. Repeat step 13. Unit should trip off at approximately 8.3 mA.

NOTE: Do not attempt to check 110% level of current trip under shorted output conditions. Rated output currents are only available through a capacitive load of sufficient value. Shorted current values should never exceed 50% of rated currents for the High Voltage Tap being used. If desired to test at 110% of current rating, the 60kV/166mA tap must be connected to a High Voltage Capacitor of approximately 3.8 nanofarads rated at 60 kVAC or higher (for 60 Hz).

15. Turn Off Main Power Circuit Breaker on Controls.

END OF OPERATIONAL VERIFICATION TEST!

GENERAL TEST PROCEDURE

1. Make sure that Main Power Circuit Breaker on the Control Panel is in the Off position.
2. Make sure that all electrical connections have been properly and securely made, and that the test specimen is properly connected to the High Voltage Transformer (refer to Initial Set-up Procedures).. Make sure the Guard / Ground / Return Jumper Clip is set properly for test being performed. Make sure that all personnel are clear of danger and that test area is clearly marked.
3. Connect Input Cable to Controls and to Power Source. Switch the Main Power Circuit Breaker on the Control Panel to the On position.
4. Set Measurement Divider switch to the position that matches the High Voltage output being used.
5. Set Overload Trip dial to desired trip-out level. (**NOTE:** In setting this device, it is important to take into account the capacitive current that the sample under test will require. Set the dial to a high enough value to preclude false failure indications. If this value is not known, it is recommended that the dial be left in a higher setting.)
6. Press the HV On switch. (**NOTE:** The following conditions must be met before High Voltage will engage: Security Circuit Loop must be closed, Emergency Off Switch must be closed (mushroom button up), Overload Reset Lamp must be off, Voltage Control at Zero Start, Transformer Power Circuit Breaker on, and Ready lamp illuminated.)
7. Raise the manual Voltage Control knob on the Control Panel until desired test voltage level is reached. Keep voltage at desired level for required duration. Record data if desired.
8. After completion of the test, manually return the Output Voltage to zero or its lowest level via the Voltage Control knob.
9. Press HV Off momentary switch.
10. If during the test a failure should occur or if the Overcurrent Trip setting is exceeded, the High Voltage will automatically shut off. In order to regain High Voltage, the Reset pushbutton must be depressed and Voltage Control knob returned to Zero.

SECTION 6: CALIBRATION

CAUTION:

Calibration should only be done by persons familiar with High Voltage testing and safety procedures.

All calibrations have been done at the factory. Periodic calibration of the output voltmeter and output currentmeter should be done annually.

NOTE: Refer to Electrical Diagram Section for schematics pertaining to the model number of your test set.

Locating the Calibration Adjustments

The calibration points are shown in the following diagram.

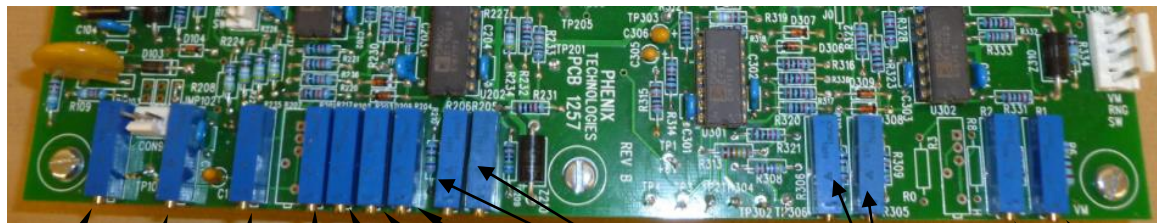

R101	R103	R235	R201	R202	R203	R204	R205	R305	R2	R1
10%	110%	Range	200mA	20mA	2mA	200µA	R206	R306	120 kV	60 kV
Ovld	Ovld	Ovld	CM	CM	CM	CM			VM	VM

NOTE:

R205, R206, and R305, R306 are set at the factory and should not be adjusted.

1. Output Voltmeter

Connect a precision high voltage voltmeter across the output to ground on 60 kV output, with Measurement Divider switch set to 60 kV. Raise the output to approximately 80% of the output rating. Adjust the reading on the panel meter (M2) by means of potentiometer R1 to a corresponding reading. Repeat procedure with precision high voltage voltmeter connected between the 120 kV output and ground with the Measurement Divider switch set to 120 kV. Adjust R2 to match precision voltmeter at 80% of output rating.

CALIBRATION

2. Output Currentmeter

It is necessary to connect adequately rated High Voltage loads (isolated from ground) to the high voltage unit that will allow each full range current to be drawn at approximately 15% or higher output voltage. This allows sufficient resolution to adjust current levels. All ranges can be calibrated from 60 kV output.

Place Binding Post Configuration in GUARD MODE. (Jumper clip is installed between GRD and GND posts.)

Connect a precision ammeter between the low potential side of the appropriate high voltage load and the RTN post. Select the 200 uA meter range. Raise the output to approximately 80% of the range rating. Adjust the reading on the panel meter (M1) by means of potentiometer R204 to a corresponding reading. Repeat for 2 mA, 20 mA and 200 mA ranges adjusting R203, R202 and R201, respectively. (High Voltage load will need to change when changing range).

An optional method is to use current injection between RTN and GND (Guard Mode).

Do not turn High Voltage on for this method!

3. Overcurrent

This calibration should not need adjustment (factory adjusted). If the Overcurrent Circuit is out of calibration, perform the following steps. To recalibrate the Overcurrent Circuit with the High Voltage Unit, it will be necessary to connect an 8-nanofarad capacitor rated at 60 kVAC or higher to the 60 kV / 166 mA output of the High Voltage Unit. If the capacitor is isolated from ground at the low potential end, the low potential end can be connected to the RTN post. The Guard Post Jumper may be connected to GRD (Guard Mode). If the low potential end of the capacitor is grounded, the Ground Post Jumper must be connected to RTN post.

- a. Set front panel Measurement Divider switch to 60kV/166mA. When current trip dial is set to minimum (1) current trip level should be approx. 17mA. When dial is set to maximum (11) trip level should be approx. 183mA.
- b. Set the Overload Trip potentiometer (R15) on the front panel to "1" and the Current Range switch to 200 mA.
- c. Turn on HV On and adjust the output current slowly until 10% of rated current is displayed on the current meter. (17 mA)
- d. Adjust potentiometer R101 until the Reset lamp illuminates and high voltage is shut off.
- e. Set the Overcurrent Trip potentiometer (R15) on the front panel to "11."
- f. Turn on HV On and adjust the output current slowly until 110% of rated current is displayed on meter.
- g. Adjust potentiometer R103 until the Reset Lamp illuminates and high voltage is shut off.
- h. Repeat steps b through g if necessary until both settings are calibrated.

4. Range Overcurrent

R235 sets an overcurrent for the ranges and should be set to trip at approximately 112% of full range current on medium range setting with current trip potentiometer set at "11."

SECTION 7: TROUBLESHOOTING

General

If the controls do not operate properly after having been used according to the instructions, the following hints may help.

- ◆ Check main facility input power to the test set.
- ◆ Check all control and switch settings.
- ◆ Check indicating lamps. (Spare lamps are available through Phenix Technologies.)
- ◆ Check Fuse F1
- ◆ Check operation of main power circuit breaker (CB1). Main Power lamp should be on.
- ◆ Check Transformer Power circuit breaker.
- ◆ Check all plug connections, internal and external, on the test set.

Specific Problems

1. High voltage cannot be turned on?

- Emergency off has been pressed – pull switch button up.
- External interlock is open (SX1).
- Voltage Control dial is not in zero start position.
- Protection circuit (Overload Trip) is not Reset.
- Transformer Power circuit breaker is off or faulty.
- Faulty HV On or Off switch.
- Faulty relay contacts.

2. Voltage control inoperable?

- Transformer Power circuit breaker faulty.
- Problem with power cable between Controls and High Voltage Unit.
- High voltage is not on (K3 is not energized or see number 1 above).
- Faulty regulator "T1."
- Faulty step-up transformer in high voltage unit (T301).

3. Overload Trip inoperable?

- Improper sensitivity (adjust Current Trip (R15) on front panel).
- Defective U101, C-1, SCR 101 (C-2).
- Check the +22 volts DC and +15 volts DC regulator (REG. 4) on PCB 1257, C-2 (TP5).
- Check LP4 (RESET) and relay K101 on PCB 1257, C-2.

TROUBLESHOOTING

Specific Problems (cont'd)

4. **Currentmeter inoperable?**

- Binding post jumper clip installed between ground and guard with a grounded test object.
- Connection between currentmeter and high voltage test specimen return connected improperly.
- Meter damaged
- Faulty TX1 interconnect cable.
- Damaged or inoperative range switch or wiring.
- Faulty Circuit on PCB1257.

5. **Voltmeter inoperable?**

- Faulty TX1 interconnect cable.
- Meter damaged
- No high voltage present at output bushing.
- Damaged or inoperative Measurement Divider Switch.
- Faulty circuit on PCB1257.

6. **No output voltage from high voltage section?**

- Defective metering circuit.
- No input to voltage regulator section, possible problems with K3, regulator (T1), or with Transformer Power circuit breaker.
- Internal connection broken.
- High voltage winding of T2 short circuited.
- Refer also to Specific Problems 1 and 2.

SECTION 8: MECHANICAL MAINTENANCE

General

No solution or chemical stronger than an ordinary household cleaner should be applied to the cabinet area of this unit. Care must be used when cleaning the meter faces and console panel. Abrasives may remove printing and descriptive titles and scratch meter faces. When cleaning, always have unit disconnected from power source. Never attempt to clean inside the unit as the cleaning solution may cause damage to the electronic components.

High Voltage Transformer

Surface

All surfaces are finished with heavy duty paints and will provide adequate protection against the elements in normal use. It is recommended that the finish be wiped down with nothing stronger than ordinary household cleaner for longer life and also for proper electrical operation of the unit. Also inspect all fabrication joints for oil leakage. If a leak is found, consult Service Department at Phenix Technologies..

Control Box / Regulator Section

At least once every year, the control assembly should be removed for inspection of the regulator assembly and other parts. If dust and dirt are present, cleaning with a dry brush and air hose should be sufficient. Inspect the voltage regulator contact surfaces for any signs of burning or wear. The brushes are the carbon type and are constructed to provide a 1/8"- wide contact point. If they are worn down so as to be nearing (approximately) 1/32" at the wider part of the brush, they should be replaced.

The only other mechanical maintenance needed on the control box is that it be kept clean.

Transformer Oil Maintenance

At time intervals, ranging from six months to one year, the oil purity (see next page) should be checked in the high voltage transformer to verify its reliability. If the transformer is subject to adverse weather conditions or an oil leak develops, the oil purity should be checked regularly.

SECTION 9: CHECKING OIL PURITY

NOTE: Typical test data for the oil used by Phenix Technologies are provided at the end of this section.

1. The most reliable means of determining the purity of the oil in the field is to test the dielectric strength. Test sets for this purpose available on the market differ in design, particularly in the shape of the electrodes and the test container. Tests on samples from the same oil carried out with electrodes of different types give different breakdown values for the same distance between the electrodes. Oil test values should therefore always be accompanied by information about the type of test gap used. The most common types of test gaps are:

- a. Cylinder gap.
- b. Spheres, 12.5 m in diameter.
- c. Flat discs, 25 mm in diameter.
- d. Segments of spheres, 35 mm in diameter, radius of sphere 25 mm.

Phenix employs for field testing Gap C, flat discs, which is per ASTM specification D-877.

2. Regardless of which type of test gap is used, it is important that container and electrodes be well cleaned and dried before oil filling. Cleaning should be done per the instructions with the oil testing equipment.

3. Sample the oil both at the top and the bottom of the transformer, if possible. In general, with small (portable) transformers, it may not be practical to sample the bottom oil. Phenix recommends a minimum test level of 30 kV when using the ASTM D-877 test procedure. If the oil tests lower than this, consult Phenix Technologies' Service Department for recommendations. Generally, for small (portable) transformers with small oil volumes, draining and refilling with new or repurified oil will be recommended. If filtering is recommended, proceed as follows:

- a. Perform the purification of contaminated oil in a transformer by circulating the oil between the transformer and the purification plant, drawing off the oil at the base and returning it at the top of the transformer. If the oil is heated in the purification plant, a stratification of heated and unheated oil will take place in the transformer. As the different oil layers mix very little, the circulation of the oil quantity will be more effective, thus reducing the time needed for treatment of the oil. Circulation of the oil is carried on until oil tests indicate that the desired oil quality is obtained. After circulation, the oil level is adjusted in accordance with the instruction plate on the transformer to the correct level at the prevailing oil temperature.

- b. When making or changing connections, always fill the feed hose completely with oil before opening the bottom valve on the transformer. If this precaution is not taken, the air in the hose, which may have considerable volume, will be forced into the transformer with the oil stream.

NOTE: If air has been injected into the oil, it is recommended that a period of two days be allowed after completion of oil filling until energizing to allow the oil to absorb any occluded air or gas in the insulation.

4. Oil Specifications

Transformer oil is a high quality insulating oil specially refined and formulated to meet the exacting requirements of major electrical equipment manufacturers and users. It also meets Federal Specification VV-I-530a.

High quality mineral-based transformer oil is recommended as the insulating and cooling medium for oil-immersed transformers. It is also recommended for arc-forming apparatus such as switches, circuit breakers, tap changers, reclosers, and fuses. General Characteristics of transformer oil include:

CHECKING OIL PURITY

a. High Dielectric Strength:

Transformer Oil has high electrical insulating values as shown by their dielectric strengths of over 30,000 volts.

b. Excellent Oxidation Stability:

Excellent oxidation stability and high resistance to sludging provide protection, particularly where high temperatures are likely to be encountered. These products are specially refined to ensure long time service with a minimum of maintenance.

c. Freedom From Contaminants:

Absence of organic acids, corrosive sulfur, and other foreign materials, which might affect metals or insulation, ensures long life for the oil as well as the electrical units.

d. High Interfacial Tension:

High interfacial tension shows the absence of soluble polar contaminants. Refinery sealed containers assure maintenance of purity in transit.

e. Good Heat Transfer Properties:

Good circulation and rapid transfer of heat from the coils to the cooling fins are assured by low viscosities at all operating temperatures.

Typical Test Data for Transformer Oil

TEST	METHOD	UNITS	SPECIFICATION
Moisture	ASTM D1533	Mg/kg	35 max
Color	ASTM D1500	ASTM	0.5 max
DDF (Power Factor) @100°C	ASTM D924	0.3 max	0.3 max
Breakdown voltage (2mm gap)	ASTM D1816	kV	35 min
Inhibitor Content	ASTM D2668	%w/w	0.30 max
Interfacial tension	ASTM D971	dynes/cm	40 min
Density @15°C	ASTM D1298	g/ml	0.91 max
Viscosity @ 100°C	ASTM D445	cSt	3.0 max
Viscosity @ 40°C	ASTM D445	cSt	12.0 max
Viscosity @ 0°C	ASTM D445	cSt	76.0 max
Refractive Index	ASTM 1218	Units	
Carbon N%	ASTM D2140	%	
Carbon A%	ASTM D2140	%	
Carbon P%	ASTM D2140	%	
Corrosive Sulfur	ASTM D1275B		Noncorrosive
PCBs – Detection Unit 1 mg/kg	ASTM D4059	mg/kg	Not Detected
Flash Point	ASTM D92	0°C	145 min

SECTION 10: TRANSPORTING / STORAGE OF EQUIPMENT

In some instances there is a requirement for transporting the equipment from one location to another for on-site field testing. If such conditions prevail, the following precautions should be adhered to.

1. **Control Box / Regulator Section**

Anchor sufficiently to prevent movement during shipment and covered with a canvas or other protective covering to prevent damage during transport.

2. **Interconnect Cables**

Cover the connectors, both male and female ends, to prevent foreign matter from entering.

3. **High Voltage Transformer**

Anchor sufficiently to prevent movement during transport and cover with a canvas or other protective covering to prevent damages during transport. Prior to operation, all insulating materials and bushings should be cleaned. Protective caps should be in place on connectors.

STORAGE OF EQUIPMENT

If the equipment will be stored for a prolonged period, the following precautions are recommended.

1. The equipment should be covered and kept in a warm, dry environment (95% maximum humidity, 5 to 50 degrees C).
2. If the high voltage transformer is to be stored outdoors, it should be completely covered to prevent damage from environmental conditions.
3. In no case should the control box be stored outdoors unless previously specified in the original purchase agreement).
4. Prior to placing the equipment back into operation, all aspects of the maintenance schedule should be strictly adhered to.

CIRCUIT DIAGRAM SYMBOLS

CIRCUIT DIAGRAM SYMBOLS
SYMBOLS POUR SCHEMA DE CIRCUIT
SYMBOLE ZU SCHEMA

REF	SYMBOL	DESCRIPTION	DESCRIPTION	BEMENKUNG
A		Amplifier	Unite d'amplificateur	Verstärker
ARSR		Surge Arrestor	Parafoudre	Ueberspannungsableiter
C		Capacitor	Condensateur	Kondensator
BSHG		Bushing	Traversee	Durchfuehung
C		Electrolytic Capacitor	Condensateur electrol	Electrolytik kondensator
F		Fuse	Fusible	Sicherung
CT		Current Transformer	Transformateur de Courant	Stromtransformer
CB		Circuit Breaker	Interrupteur	Unterbrecher
K		Relay, Contactor	Relais, Contacteur	Relais, Schütz
L		Inductor	Self	Drossel, Spule
MOT		Motor	Moteur	Motor
MOV		Movistor	Parafoudre	Movistor
NE		Neon	Parafoudre	Ueberspannungsableiter
LP		Lamp, Indicator	Lampe	Meldeleuchte
R		Resistor	Resistance	Widerstand
R		Variable Resistor	Resistance Variable	Widerstand
T		Transformer	Transformateur	Transformer
TB		Terminal Block	Borne	Lösbare Klemme
X		Connector	Prise de Courant	Steckverbindung
K		Relay Contact Normally Open	Contact Normalement Ouvert	Schlierskontakt
K		Relay Contact Normally Closed	Contact Normalement Ferme	Oeffnungskontakt
K		Changeover Contact	Contact de Changement	Umschaltkontakt
		Shielded Wire	Cable blindé	Abgeschirmetes Kabel
TR		Transistor	Transisteur	Transistor
M		Analog Meter	Instrument Analogue	Analog Meter
D		Diode	Diode	Diode
Z		Zener	Diode Zener	Zener
SCR		Thyristor	Thyristor	Thyristor
SW		Normally Open Maintained Switch	Interrupteur Normalement Maintenu Ouvert	Schrittschalter (Schliesser)
SW		Normally Closed Maintained Switch	Interrupteur Normalement Maintenu Ferme	Schrittschalter (Oeffner)
SW		Normally Closed Momentary Switch	Interrupteur Normalement Ferme Momentanement	Druckschalter (Oeffner)
SW		Normally Open Momentary Switch	Interrupteur Normalement Ouvert Momentanement	Druckschalter (Schliesser)
DP		Current Overload Device	Dispositif De Súr Intensité	UeberstromschutzEinheit

SECTION 12: ELECTRICAL DIAGRAMS

Drawing Number

Description

9602016

6CP120-10 (220V, 50/60 Hz) System Diagram

SECTION 13: PARTS ORDERING INFORMATION

Replacement parts are available from Phenix Technologies, Inc.

Changes to Phenix Technologies' products are sometimes made to accommodate improved components as they become available, and to give you the benefit of the latest technical improvements developed in our Engineering Department. It is, therefore, important when ordering parts to include the serial number of the unit as well as the part number of the replacement part.

When your purchase order is received at our office, a representative of Phenix Technologies will contact you to confirm the current price of the part being ordered. If a part you order has been replaced with a new or improved part, an Applications Engineer will contact you concerning any change in part number.

Your order for replacement parts should be sent to:

Service Department
Phenix Technologies, Inc.
75 Speicher Drive
Accident, Maryland 21520

Ph: 1 (301) 746-8118
Fax: 1 (301) 895-2770
E-mail: info@Phrnixtech.com

SECTION 14: RECOMMENDED SPARE PARTS

Phenix Technologies recommends that the customer purchase and stock the following parts for normal maintenance of the unit. The recommended quantity should be sufficient to support the unit during normal operation.

If the unit will be operated at an isolated site for an extended period or will be subjected to unusual stresses, a larger quantity of parts should be stocked as spares. In such a case, contact your Phenix Technologies' sales representative for a recommendation.

Current prices may be obtained by contacting the Parts Ordering Department at Phenix Technologies.

<u>Part Name</u>	<u>Computer Number</u>	<u>Recommended Quantity</u>
LCD Meter, KNS 3 ½ Digit DMO-66T	1506400	1
Lamps, 31-963.4, EAO 60V	1420150	5
Limit Switch, 2HBA190-1 (SW7)	1866005	1
Switch, Mom., 1 Pole, 31-121.025 EAO (HV on, HV off, Reset)	1860120	1
Fuse, 0.5 A, 3AG (F1-2)	1603599	2
Rotary Switch –4P, 2-3 Pos.	1863048	1
Relay (K3)	1705465	1

SECTION 15: PARTS LIST

Item	Part Number	Description	Quantity
CONTROL SECTION			
LP1	1423300	31-040-005 SOCKET	1
LP1	1422153	31-903.7 LENS CLEAR	1
LP1-4	1420150	10-1320-1179 EAO LAMP 60V	4
LP2	1422150	31-903.2 LENS, EAO RED	1
LP3	1422151	31-903.5 LENS, GREEN	1
LP4	1422148	31-903.6 LENS, BLUE	1
M1	31126500	PCB1265: CM PROT BD-KNS-ZENERS ONLY	1
M1, M2	1506400	KNS DMO-66PHX 3 1/2 DIG LCD	2
M2	31126501	PCB1265: VM PROT BD-KNS-ZENERS/CAPS	1
METER PLUG	1152210	1-640440-0, CON 10CKT.1	2
MLX2	1153970	MOLEX PLUG #03-09-1040 4P	1
MLX2	1153915	MOLEX F PIN 02-09-1104	4
R15	1761098	10 K, 2 W, LINEAR	1
R15 DAL	1355905	47-15-023 STATOR BLACK	1
R15 DIAL	1355102	31-15-10-1 PEAKED CAP	1
R15 DIAL	1355101	26-15-61-3 KNOB	1
R15 DIAL	1355910	46-15-010 DIAL 30-0-11	1
R16A-C	1720201	.5W, 180 OHM, 1%	3
SW10	1860265	31-262.025 EAO LATCH 2POLE	1
SW10	1420150	10-1320-1179 EAO LAMP 60V	1
SW10, SW11	1422153	31-903.7 LENS CLEAR	2
SW11	1860260	31-261.025 EAO LATCH 1POLE	1
SW2-4	1860120	31-121.025 EAO, MOM. 1POLE	3
SW5	1863049	ROTARY SW 3P 2-4 POS-S (10WA356)	1
SW5, SW9	1355310	KNOB PKAP-50B-1/4	2
SW7	1866005	SW, ROLLER, 20A Z-15GW22-B7-K	1
SW8	1862905	SIEMENS# 3SB3400-OC, NC	1
SW8	1860900	KEY SWITCH #3SB3000-1BA20	1
SW9	1863048	ROTARY SW 4P 2-3 POS-S (10WA367)	1
SX1 CBL	1151186	CBL CLAMP, SIZE 11 SMALL	1
SX1 CBL	1151162	AMP 4M PIN CBL PLUG, SIZE 11	1
SX1 CBL	1151176	CONTACT PINS, SOLDER, MALE	2
SX1 CHS	1151174	CONTACT PINS, 24-20 AWG, FEMALE	2
SX1 CHS	1151152	AMP CHS RCPT., 4F PIN, SIZE 11	1
TMR1	1480120	DIGITAL TIMER, OMEGA #PTC-13	1
TX1 CBL	30160001	20' ST-ST 6PR SHL'D CABLE ASSY	1
TX1 CHS	1151170	CONTACT PINS, 24-20 AWG, MALE	10
TX1 CHS	1151158	AMP CHS RCPT., 16M PIN, SIZE 17	1
RTN CBL	30080010	RTN CBL-LG RED TST LEAD-20' PLIER	1
PCB	31125723	PCB1257: 6CP120-10 CONTROL BOARD	1
GND CBL	30080018	GRN/YEL 10 AWG GND CBL-20'-RING LUGS	2

PARTS LIST

Item	Part Number	Description	Quantity
REGULATOR			
CB1	1601332	30A 2P CKT BRKR 250V (CE)	1
CB2	1601333	30A 3P CKT BRKR 250V (CE)	1
CON1	1151183	MALE CONTACT PINS, 1 GOLD, 10-8 AWG	3
CON1	1151178	HIGH CUR. RCPT. 3M PIN SIZE 17	1
CON2	1151179	HIGH CUR. RCPT,3F PIN,SIZE 17	1
CON2	1151185	FEMALE CONTACT PINS, 1 GOLD, 10-8 AWG	2
F1-F2	1603920	#345613A 1P PNL MNT FUSEHLDR (3 AG)	2
F1-F2	1603599	AGC-0.5	2
INPUT PWR	30110008	BK130 INPUT POWER CBL-30',10/3	1
INTER PWR	30110007	BK130 PWR INTERCONNECT-20',10/2	1
K3	1705465	FUR. 42BF35AF 30A/3P 120V	1
MLX1	1153915	MOLEX F PIN 02-09-1104	2
MLX1	1153910	MLX PLG, 03-09-1022 2P	1
MOV1	1606110	MOVISTOR V275LA40A	1
T1	1890239	VARIABLE XFORMER VOLT-PAC 9T92A40	1
T2	1896017	SIEM.#MT0050A	1
HIGH VOLTAGE CYLINDER AND BASE			
BP GROUND	1351103	BINDING POST (GREEN) 459-105	1
BP GUARD	1351104	BINDING POST 459 WHITE	1
BP RETURN	1351102	BINDING POST 459-102 RED	1
BP SHORT	1351110	SHORTING BAR	1
CAPS	1151196	SIZE 17 CAP	2
CON3	1151183	MALE CONTACT PINS, 1 GOLD, 10-8 AWG	2
CON3	1151178	HIGH CUR. RCPT. 3M PIN SIZE 17	1
D301-304	1780066	5KP13A 10V TRANSORB	4
MOV301-303	1606110	MOVISTOR V275LA40A	3
MOV301-303	1110700	PC1070 3 PC. MOVIST.BD	1
R301A,B,C	1748351	12W, 150 MEG,1%,SC-END,(SSX103)	3
R302A,B	1748351	12W, 150 MEG,1%,SC-END,(SSX103)	2
R303-304	1724400	.5W, 200K, 1%	2
R305A,B,C	1720230	.5W, 220 OHMS, 1%	3
R306	1740185	10W, 30 OHMS,1% WIRE WOUND	1
R306-309	1112231	PCB 1223 REV A	1
R307	1720600	.5W, 300 OHMS, 1%	1
R308	1722087	.25W, 3.0K 1% (271-3.0K)	1
R309	1722570	.25W, 30K, 1%	1
SPG301-304	1605110	CG90L, CPL SPKGAP 90V	4
T301	38342930	GO1-2930	1
TX1	1151158	AMP CHS RCPT.,16M PIN, SIZE 17	1
TX1	1151170	CONTACT PINS, 24-20 AWG, MALE	9

SECTION 16: RETURNED MATERIAL

If for any reason it should become necessary to return this equipment to the factory, the Service Department of Phenix Technologies, Inc. must be given the following information:

Name Plate Information

Model Number

Serial Number

Reason for Return

Cause of Defect

If Phenix Technologies, Inc. deems return of the part appropriate; it will then issue an "Authorization for Return."

If return is not deemed advisable, other inspection arrangements will be made.

NOTE: Material received at this plant without the proper authorization shall be held as "Customer's Property" with no service until such time as the proper steps have been taken.

Your cooperation is requested in order to ensure prompt service.

