

# USER'S MANUAL



## AC DIELECTRIC TEST SET CASCADE TYPE

Model Number 6CP200/100-10

Version 2.1

**Phenix Technologies, Inc.**  
75 Speicher Drive  
Accident, Maryland 21520

Copyright © Phenix Technologies, Inc.

Rev 2/9/2015  
nab

6CP200/100-10

# TABLE OF CONTENTS

<u>DESCRIPTION</u>	<u>SECTION NUMBER</u>
DANGER / GENERAL SAFETY PRECAUTIONS	
TECHNICAL SPECIFICATIONS	1
UNCRATING PROCEDURE	2
CONTROLS AND INDICATORS	3
INITIAL SET-UP—MECHANICAL / ELECTRICAL	4
OPERATIONAL VERIFICATION / GENERAL TEST	5
CALIBRATION	6
TROUBLESHOOTING	7
MECHANICAL MAINTENANCE	8
CHECKING OIL PURITY / SPECIFICATIONS	9
TRANSPORTING / STORAGE OF EQUIPMENT	10
CIRCUIT DIAGRAM SYMBOLS	11
ELECTRICAL DIAGRAMS	12
PARTS ORDERING INFORMATION	13
RECOMMENDED SPARE PARTS	14
PARTS LIST	15
RETURNED MATERIAL	16
CUSTOMER COMMENTS / SUGGESTIONS	17
ATTACHMENTS	
PTC-13 TIMER MANUAL	

## GENERAL SAFETY PRECAUTIONS



# CAUTION

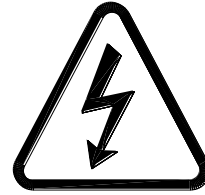

### HIGH VOLTAGE

**This equipment is capable of providing POTENTIALLY LETHAL VOLTAGES! Improper operation or test practices may result in injury or death to the operator or surrounding personnel.**

The operation of High Voltage test equipment should only be performed by personnel familiar with HIGH VOLTAGE testing and safety procedures. The operator of this equipment must be aware of all hazards associated with High Voltage testing. The operator is responsible for himself and others in close proximity of the testing area.

Some General Safety Practices for working with High Voltage Test Equipment have been listed below for your reference.

- Get familiar with your instrument before performing an actual test
- Know your work area, check that all circuits are de-energized and locked out.
- Never work alone; always work with another qualified worker.
- Mark off entire work area with barriers and warning tape.
- Make all personnel aware of your testing activities.
- Be aware of dangerous conditions that may arise from energizing a test specimen.
- Never modify test equipment, modifications to equipment could introduce an unknown hazard or hinder a designed-in safety feature.
- DO NOT operate damaged equipment. Remove power, and do not use the equipment until safe operation can be verified by service-trained personnel.

Phenix Technologies, Inc. assumes no liability for unsafe or improper use of test equipment.

# TECHNICAL SPECIFICATIONS

## Input

220-240 volts, single phase, 50/60 Hz, 25 amperes

## Output Rating

Series Connection: 200 kilovolts, 50 milliamperes  
5 minutes ON / 15 minutes OFF @ 10 kVA

Parallel Connection: 100 kilovolts, 100 milliamperes  
5 minutes ON / 15 minutes OFF @ 10 kVA

Single Cylinder: 100 kilovolts, 50 milliamperes  
5 minutes ON / 15 minutes OFF @ 5 kVA

## Type of Cooling

ONAN (Oil / Air Natural Convection)

## Operating Ambient Temperature

10 – 40 degrees C

## Output Termination

High Voltage Electrode

## Metering - Digital

Output Voltmeter: 3 ½ Digit LCD, Accuracy  $\pm(0.8\%$  of reading + 0.2% of range)  
2 Ranges: 0-100kV, 200kV

Output Currentmeter: 3 ½ Digit LCD, Accuracy  $\pm(0.8\%$  of reading + 0.2% of range)  
4 Ranges: 0-200 $\mu$ A, 2mA, 20mA, 200mA

## Sizes and Weights

Control/Regulator Section: 21.25" (540mm) W x 16.75" (426mm) D x 13.75" (350mm) H;  
220 V – 52 lbs (24 Kg)

High Voltage Cylinder (2): 16" (406mm) W x 16" (406mm) D; X 30" (762mm) H;  
178 lbs. (81 kg)

High Voltage Divider: 9" (229mm) W x 9" (229mm) D; X 43" (1092mm) H;  
40 lbs. (18 kg)

## Additional Equipment

Cart (2): 22.5" (572mm) W x 29.25" (743mm) D x 50" (1270mm) H;  
61 lbs. (27.7 kg)

Cables: 20 lbs. (9.1 kg)

Total Unit Weight: 220V – 309 lbs. (140.2 Kg)

## **SECTION 2: UNCRATING PROCEDURE**

1. Exercise care in removing shipping materials so as not to damage unit.
2. Perform visual inspection to determine if unit was damaged during shipment. If there are any signs of physical damage (such as dents, scratches, oil leaks), contact the Service Department at Phenix Technologies before proceeding.

## SECTION 3: CONTROLS AND INDICATORS

Control Panel  
Figure 3-1

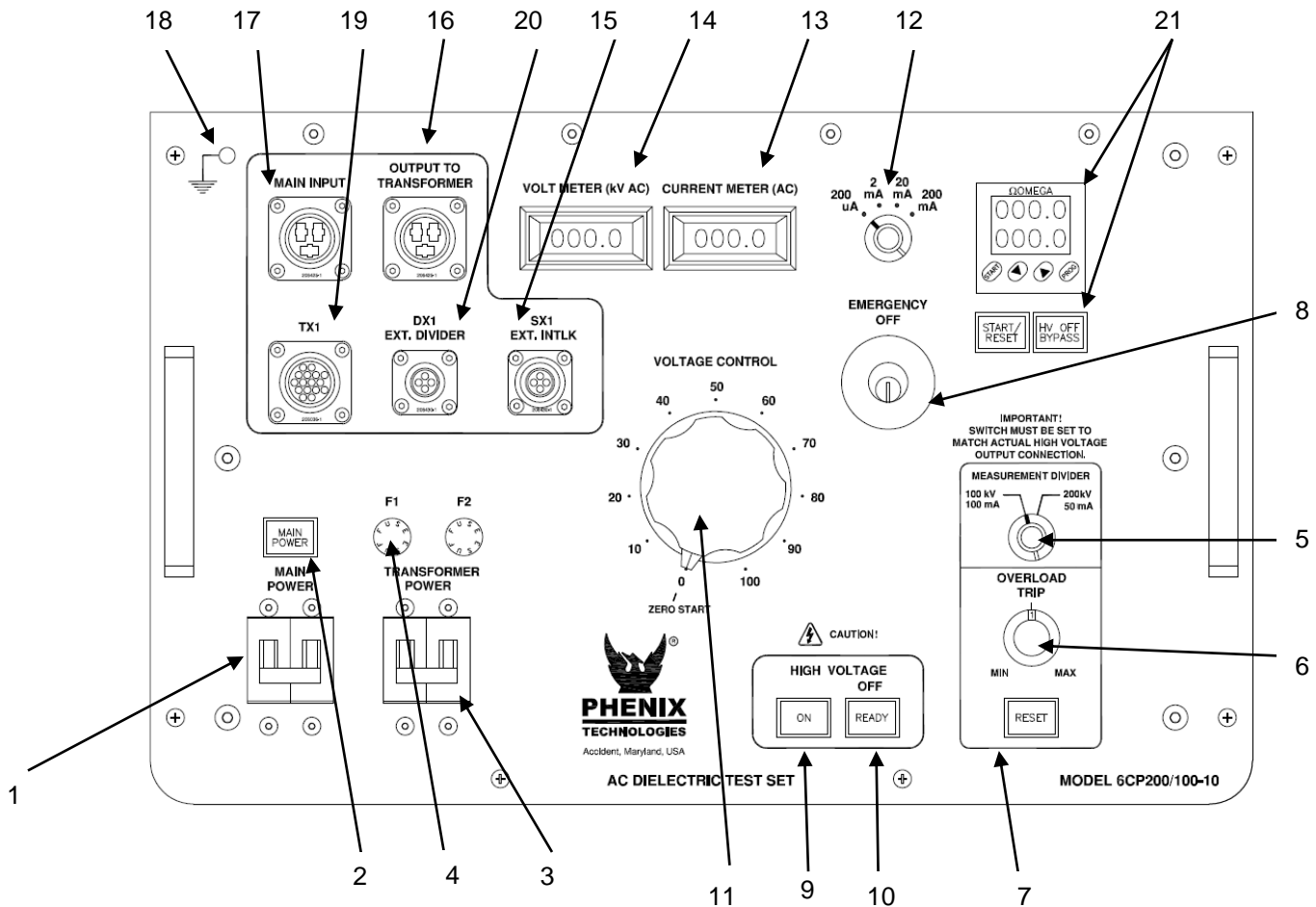

Descriptions are keyed to Figure 3-1

1. **Main Power Circuit Breaker.**
2. **Main Power Indicator**
3. **Transformer Power Circuit Breaker.**
4. **F1, F2 Control Power Fuse.**
5. **Measurement Divider Switch.** Selects proper overload and voltmeter circuitry for the HV output terminal being used. Match switch setting to output being used on HV transformer.
6. **Overcurrent Trip.** Use for presetting desired Overcurrent trip setting. Range approximately 10-110% of rated current.
7. **Reset.** Will light when Overcurrent Trip setting is exceeded. Push to reset. Lamp must be extinguished for HV ON.

## CONTROLS AND INDICATORS

### Control Panel (Cont'd)

8. **Emergency Off switch.** Press to immediately shut off all power.
9. **High Voltage On Switch and Indicator Lamp.** Turns on output voltage when Ready indicator is illuminated.
10. **High Voltage Off Switch and Ready Indicator Lamp.** Turns HV off, indicator shows when all conditions are met to turn H.V. ON. (External Interlock closed, Reset Lamp off, Emergency Off Button pulled up, Voltage Control at Zero).
11. **Voltage Control.** Adjusts Output Voltage and must be set at zero to turn High Voltage on.
12. **Currentmeter Range Selector.**
13. **Output Currentmeter.**
14. **Output Voltmeter.**  
  
**NOTE:** 200kV voltmeter range is calibrated at 80% of range. 100kV range may not be accurate above 100% of range.
15. **SX1 External Interlock.** Provides for user connection of external interlock or auxiliary safety control device such as Emergency Off Switch, Gate Switch, Footswitch, Dead Man Switch, etc.
16. **Output to Transformer.** High Voltage transformer power connection.
17. **Main Input.** Main input cable connects here.
18. **Ground Terminal.**
19. **TX1.** Signal/Metering cable between HV Cylinder and controls connects here.
20. **DX1.** Signal/Metering cable between HV Divider and controls connects here.
21. **Timer** Press START/RESET to start the timer after test voltage has been reached. Press START/RESET again to reset timer to the original setting. Press HV OFF BYPASS to allow high voltage to remain on after the timer has expired. Test time can be set using the buttons on the face of the timer.

# CONTROLS AND INDICATORS

## High Voltage Transformer

Figure 3-2

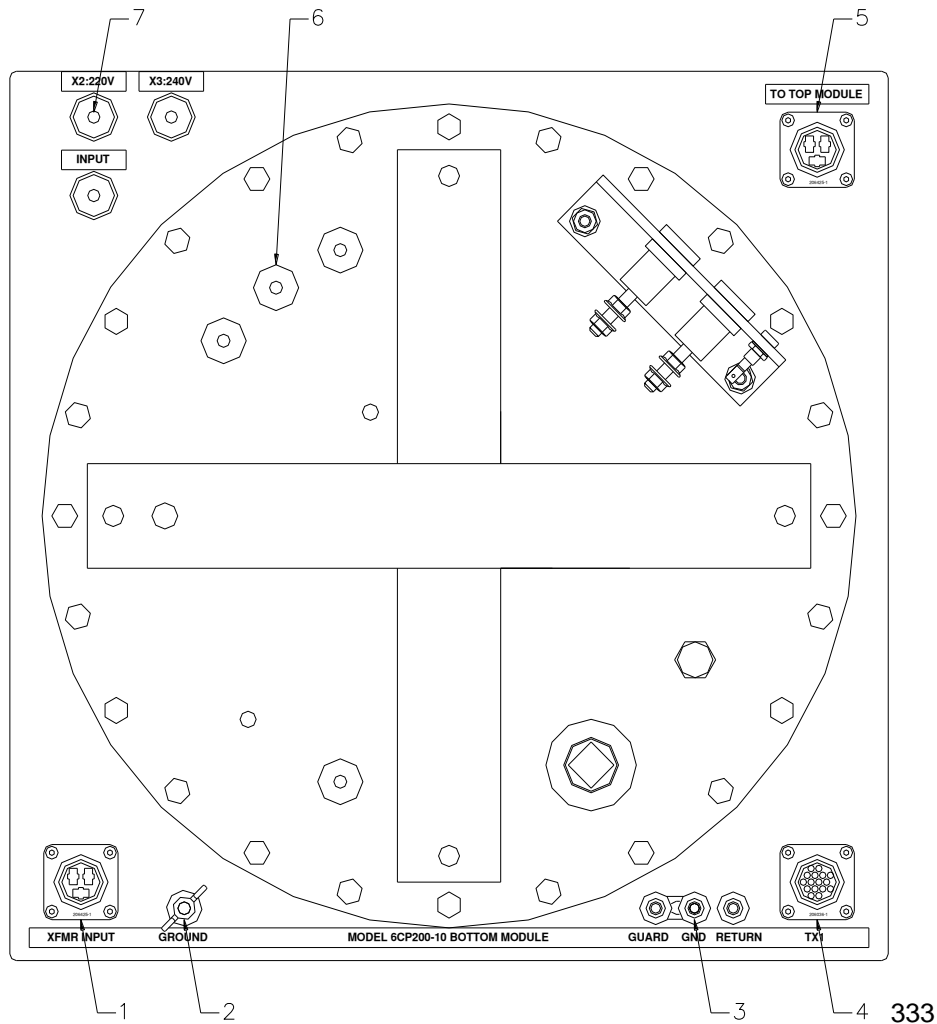

Descriptions are keyed to Figure 3-2

1. **Power Connector.** Connect the Power Cable from Output to Transformer connector on control box at this point.
2. **High Voltage Ground Point.** A ground cable from facility ground or earth ground must be connected here.
3. **Ground/Guard/Return Circuit.** Select current to be read on currentmeter. Care must be taken to ensure that test specimen can be isolated from ground before using this option.
4. **TX1 Connector.** Signal/Metering cable connects from here to TX1 on control box.
5. **Power Connector.** Connect power cable from this point to multilamm style connectors on Top Module.
6. **Lundey.** Provide sealed air-to-oil interface for connections.



## CONTROLS AND INDICATORS

### High Voltage Transformer (cont'd)

7. **Input Voltage Select.** This jumper is used to select the input voltage in single cylinder and series operation. In parallel operation, the Top Module connection must match this jumper position.
8. **High Voltage Electrode.** (not shown) Provides connection point for HV output, and provides corona shielding for lundeys and cylinder edge.

## SECTION 4: INITIAL SET-UP--MECHANICAL

1. Set up object under test.
2. The area to be used for the test must provide sufficient mechanical and electrical clearances. The approximate weight of each section is available from the nameplates or the Specification page.
3. If the unit is to be operated indoors, be sure the floor will be strong enough to support the unit. If operating outdoors, the site for the base must be capable of supporting the unit without any settling that would tilt the assembly.
4. Position the High Voltage Transformer Modules, High Voltage Divider,3 and Control Unit as necessary for operation. The Control Unit may be operated from either cart or any flat desk or floor surface.
  - **NOTE:** For parallel operation, the two transformer modules must be placed a small distance apart with the base openings facing the same direction. Transportation strap must be removed from Top Module. For series operation, base must be removed from Top Module. Remove 100kV electrode on the Bottom Module. Cylinders should then be stacked and bolted together.
5. Clean High Voltage Modules using nothing stronger than ordinary household cleaner to remove all traces of any surface contamination. This cleaning should also include the High Voltage Electrodes.

## INITIAL SET-UP--ELECTRICAL

### WARNING:

**Ground the output of the High Voltage Transformer until set-up is complete! Be sure the Main Power Circuit Breaker is in the OFF position before proceeding. This equipment should only be operated by personnel familiar with High Voltage Testing and Safety Procedures.**

#### 1. Grounding Connections:

- Use one of the supplied ground wires for making the ground connection between the control box and the ground stud on the base of the Bottom Module.
- Use another supplied ground wire to connect the facility ground to the Bottom Module ground stud.
- If operating the Modules in parallel, use the paralleling cable to ground the Module bases together.
- Use the last supplied ground cable to ground the HV Divider to the Bottom Module ground stud.
- Connect the test specimen's "low side" or ground to the ground stud on the Bottom Module using the supplied return lead.

#### 2. If the external interlock function is to be used, remove the jumper on the male cable end of the SX1 connector, and connect the external security circuit or footswitch at these points.

**NOTE:** The external interlock circuit must consist of a closed loop of dead contacts; an open circuit prevents the high voltage output from being energized. When the control power is on, the external circuit will be energized with 120 volts AC.

#### 3. Connect divider cable between Control Unit DX1 connector and DX1 connector on the Divider.

#### 4. Connect signal / metering cable between Bottom Module TX1 connector and TX1 connector on the Controls.

#### 5. Connect the power cable from the Bottom Module to the 'Output to Transformer' connection on the control box.

**NOTE:** If parallel operation, connect the paralleling cable from Bottom Module 'To Top Module' connector to multilamm style connectors at base of Top Module. These connections must match Voltage Select jumper on Bottom Module base. If series connection, connect the provided short jumpers between the multilamm connectors on the top header of the Bottom Module and the bottom header of the Top Module.

#### 6. Connect the test object to the output termination of the high voltage transformer and HV Divider. Insure that the connection is applicable for test level and type of test and that the connection has sufficient safety clearances for the voltage rating. Three high voltage output connections are possible:

- 100kV, 50mA: This output is achieved using a single cylinder. Set the Measurement Divider switch (see Section 5) to the 100 kV/100mA position when using this output. This sets the metering and overload properly for the output being used.
- 100kV, 100mA: This output is achieved by stacking the cylinders and connecting them in parallel using the supplied paralleling cable. The 100kV output is taken from the output electrodes of both cylinders. Set the Measurement Divider switch (see Section 5) to the 100 kV/100mA position when using this output.
- 200kV, 50mA: This output is achieved by stacking the cylinders and connecting them in series. The 200kV output is taken from the top electrode of the top cylinder. Set the Measurement Divider switch (see Section 5) to the 200 kV/50mA position when using this output.

## INITIAL SET-UP--ELECTRICAL

A wire can be used to make this connection; however, for best results (less corona leakage current), route a wire down the center of a one-inch diameter pipe (either aluminum or copper), and solidly connect the ends of the wire to the output tap and the test specimen. The pipe should also be solidly connected at each end.

- 7.. Connect the input main power cable to the Main Input connection at the control box and then to the facility power source.

### CURRENT METER GUARD CIRCUIT:

There are three terminals on the base of the high voltage transformer; white GRD (Guard), green GND (Ground), and a red RTN (Return). There is a metal jumper that must always be connected between either the GND and GRD terminals or the GND and RTN terminals.

Refer to Figure 4-1 on the next page:

#### Standard Mode

In this configuration, the current meter measures all leakage current from the high voltage electrode. Measured current includes specimen leakage and stray leakage.

#### Guard Mode

In this configuration, only the leakage current from the high voltage electrode through the test specimen to the RTN terminal is measured by the current meter. Any stray leakage current to ground is guarded out (bypasses the meter) and is not measured. Stray leakage current to ground can be from several sources. The high voltage transformer has some capacitive leakage to ground. The high voltage connection might have some leakage due to partial discharge (corona). The test specimen might have some leakage current to ground, and your application requires that this "stray" leakage not be measured.

#### Electrical Setup

In either configuration, the high voltage transformer's ground stud must always be connected to earth ground. The GND terminal referred in the following two paragraphs is internally connected to the ground stud.

For standard current measurement, connect the jumper between the GND and RTN terminals. Connect the test specimen return (low voltage side) to the RTN terminal.

For guarded current measurement, connect the jumper between the GND and GRD terminals. Connect the test specimen return (low voltage side) to the RTN terminal. Do not connect the specimen return to ground. The test specimen must be totally isolated from ground.

# INITIAL SET-UP--ELECTRICAL

## CURRENT METER GUARD CIRCUIT

Figure 4-1

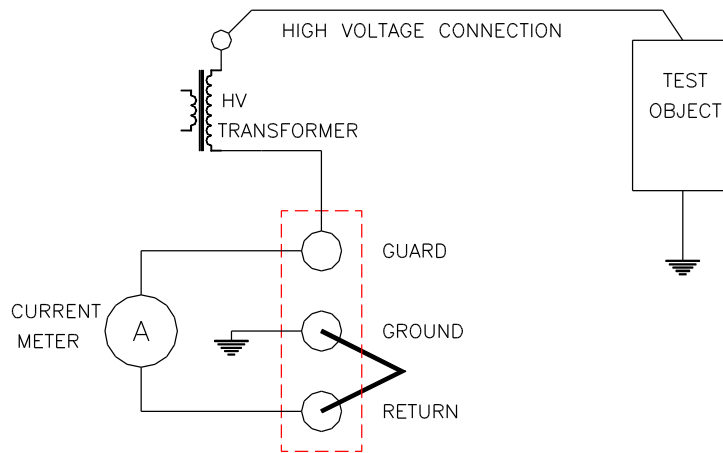

STANDARD MODE

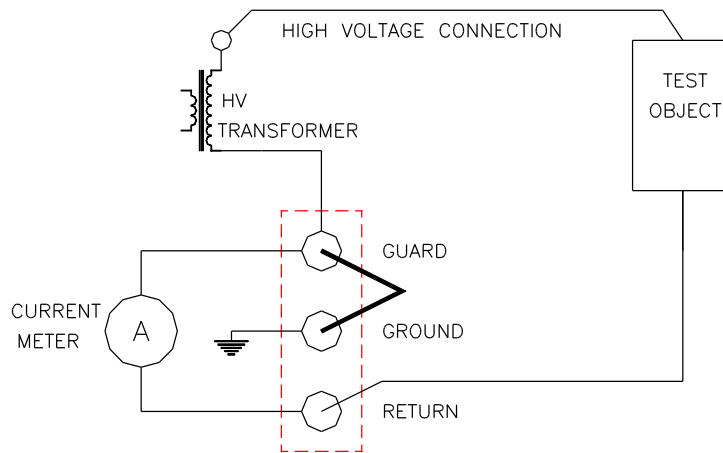

GUARD MODE

## SECTION 5: OPERATIONAL VERIFICATION PROCEDURE

### WARNING:

This equipment should only be used by personnel familiar with High Voltage testing and safety procedures.

1. Make sure that Main Power Circuit Breaker on the Control Panel is in OFF position. Ground output of high voltage unit.
2. Connect high voltage cylinders for series operation. (See drawing #763992894)
3. Make sure that all electrical connections have been properly made between the Controls and High Voltage Unit, and Divider, including grounds. Remove Ground from HV Transformer output. There is NO connection to the high voltage output at this time (except high voltage divider). There must be adequate clearance from the High Voltage Unit to allow voltage to be raised safely.
4. Connect Main Input Power Cable to Controls and to Power Source. Switch the Main Power Circuit Breaker on the Control Panel to On position. Main Power indicator lamp should illuminate. Check that the Emergency Off button is pulled up, Voltage Control is at Zero, Reset Lamp is Off, and EXT INTLK CKT is complete or has shorting jumper in place. HV Off lamp should be illuminated.
5. Press HV On switch. Indicator lamp should illuminate. Press the HV Off switch. HV On indicator lamp should extinguish and HV Off / Ready lamp should illuminate.

**NOTE:** The following conditions **must be** met before High Voltage will engage: External Interlock loop must be closed, Emergency Off switch must be closed (mushroom button up), Overload Reset Lamp must be off, and Voltage Control at Zero.

6. Set Measurement Divider Switch to 100 kV / 100 mA
7. Press the HV On switch.
8. Manually raise the Voltage Control dial on the Control Panel to approximately fifty percent (50%). Voltmeter should indicate voltage change, and show approximately 95 to 105 kV.

**NOTE:** 100kV voltmeter range is calibrated at 80% of range. The 100kV range may not be accurate above 100% of range.

9. Select 200 kV / 50 mA on Measurement Divider Selector Switch. At 50% on Voltage Control Dial, voltmeter should read approximately 95 to 105 kV.
10. Return Voltage Control to Zero. Press HV Off switch.
11. Turn Main Power Circuit Breaker off, and connect a short between the 200kV High Voltage Output and Ground. Measurement Divider Switch is to be set at 200 kV / 50 mA.
12. Set Overcurrent Trip to low (1) setting.
13. Turn Main Power Circuit Breaker on. Press HV On switch and slowly raise voltage with the dial on the Control Panel. Output Current Meter will indicate, and at approximately 10% of output current rating, the High Voltage will trip off and the Overcurrent Indicator Lamp will illuminate. With the front panel Overload Selector Switch set at 200 kV/50 mA, the trip point should be at approximately 5 mA.
14. Return Voltage Control to zero. Press HV Off Switch. Turn off Main Power Circuit breaker.

## OPERATIONAL VERIFICATION PROCEDURE

15. Connect high voltage cylinders for parallel operation. (See drawing #763992894.)
16. Move short from 200 kV output to 100 kV output and ground. Repeat step 13. Unit should trip off at approximately 10 mA.

**CAUTION:** Do not attempt to check 110% level of current trip under shorted output conditions. Rated output currents are only available through a capacitive load of sufficient value. Shorted current values should never exceed 50% of rated currents for the High Voltage Tap being used. If desired to test at 110% of current rating, the output must be connected to a High Voltage load appropriate to the rated voltage and current of the test set.

17. Return Voltage Control to Zero. Press HV Off switch. Turn Off Main Power Circuit Breaker on Controls.

**END OF OPERATIONAL VERIFICATION TEST!**

## GENERAL TEST PROCEDURE

1. Make sure that Main Power Circuit Breaker on the Control Panel is in the Off position.
2. Make sure that all electrical connections have been properly and securely made, and that the test specimen is properly connected to the High Voltage Transformer (refer to Initial Set-up Procedures). Make sure that all personnel are clear of danger and that test area is clearly marked.
3. Connect Input Cable to Controls and to Power Source. Switch the Main Power Circuit Breaker on the Control Panel to the ON position.
4. Set Measurement Divider switch to the position that matches the High Voltage output being used.
5. Set Overload Trip dial to desired trip-out level.

**NOTE:** In setting this device, it is important to take into account the capacitive current that the sample under test will require. Set the dial to a high enough value to preclude false failure indications. If this value is not known, it is recommended that the dial be left in a higher setting.

6. Press the HV On switch. (**NOTE:** The following conditions must be met before High Voltage will engage: Security Circuit Loop must be closed, Emergency Off Switch must be closed (mushroom button up), Overload Reset Lamp must be off, Voltage Control at Zero Start, and Ready lamp illuminated.)
7. Raise the manual Voltage Control knob on the Control Panel until desired test voltage level is reached. Keep voltage at desired level for required duration. Record data if desired.
8. After completion of the test, manually return the Output Voltage to zero or its lowest level via the Voltage Control knob.
9. Press HV Off momentary switch.
10. If during the test a failure should occur or if the Overcurrent Trip setting is exceeded, the High Voltage will automatically shut off. In order to regain High Voltage, press the Reset pushbutton and return the Voltage Control knob to Zero.



## SECTION 6: CALIBRATION

**CAUTION:** Calibration should only be done by persons familiar with High Voltage testing and safety procedures.

All calibrations have been done at the factory. Periodic calibration of the output voltmeter and output currentmeter should be done approximately every six months.

**NOTE:** Refer to Electrical Diagram Section for schematics pertaining to the model number of your test set.

### Locating the Calibration Adjustments

The calibration points are shown in the following diagram.

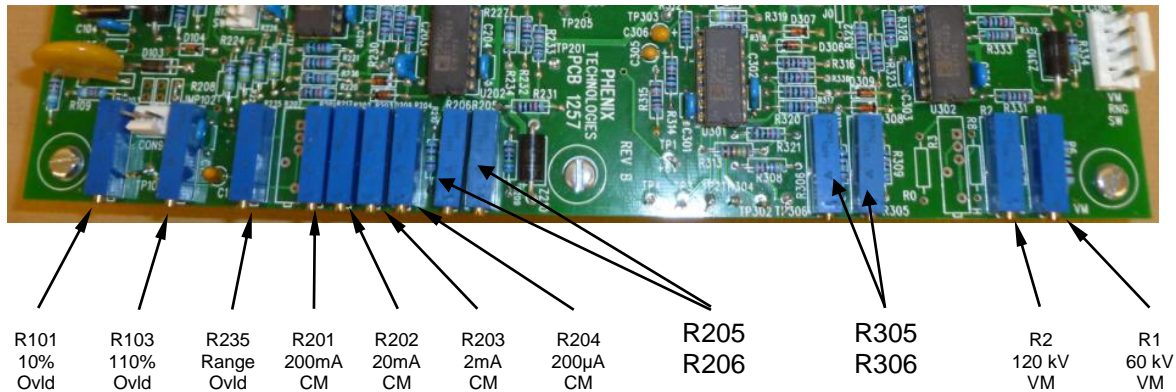

**NOTE:**

R205, R206, and R305, R306 are set at the factory and should not be adjusted.

#### 1. Output Voltmeter.

Connect a precision high voltage voltmeter across the output to ground on 100 kV output, with Measurement Divider switch set to 100 kV. Raise the output to approximately 80% of the output rating. Adjust the reading on the panel meter (M2) by means of potentiometer R1 to a corresponding reading. Repeat procedure with precision high voltage voltmeter connected between the 200 kV output and ground with the Measurement Divider switch set to 200 kV. Adjust R2 to match precision voltmeter at 80% of output rating.

#### 2. Output Currentmeter

It is necessary to connect adequately rated High Voltage loads (isolated from ground) to the high voltage unit that will allow each full range current to be drawn at approximately 15% or higher output voltage. This allows sufficient resolution to adjust current levels. All ranges can be calibrated from 100 kV parallel output.

Connect a precision ammeter between the low potential side of the appropriate high voltage load and the ground post. Select the 200 µA meter range. Raise the output to approximately 80% of the range rating. Adjust the reading on the panel meter (M1) by means of potentiometer R204 to a corresponding reading. Repeat for 2 mA, 20 mA and 200 mA ranges adjusting R203, R202 and R201, respectively. (High Voltage load will need to change when changing range).

### 3. Overcurrent

This calibration should not need adjustment (factory adjusted). If the Overcurrent Circuit is out of calibration, perform the following steps.

Set front panel Measurement Divider switch to 100 kV/100mA. When current trip dial is set to minimum (1) current trip level should be approx. 10mA. When dial is set to maximum (11) trip level should be approx. 110mA.

**NOTE:** Do not attempt to check 110% level of current trip under shorted output conditions. Rated output currents are only available through a capacitive load of sufficient value. Shorted current values should never exceed 50% of rated currents for the High Voltage Tap being used. If desired to test at 110% of current rating, the output must be connected to a High Voltage load appropriate to the rated voltage and current of the test set.

- a. Set the Overload Trip potentiometer (R15) on the front panel to "1" and the Current Range switch to 200 mA.
  - b. Turn on HV On and adjust the output current slowly until 10% of rated current is displayed on the currentmeter. (10 mA)
  - c. Adjust potentiometer R101 until the Reset lamp illuminates and high voltage is shut off.
  - d. Set the Overcurrent Trip potentiometer (R15) on the front panel to "11."
  - e. Turn on HV On and adjust the output current slowly until 110% of rated current is displayed on meter.
  - f. Adjust potentiometer R103 until the Reset Lamp illuminates and high voltage is shut off.
  - g. Repeat steps a through f if necessary until both settings are calibrated.
4. **Range Overcurrent.** R235 sets an overcurrent for the ranges and should be set to trip at approximately 112% of full range current on medium range setting with current trip potentiometer set at "11."

## SECTION 7: TROUBLESHOOTING

### GENERAL

If the controls do not operate properly after having been used according to the instructions, the following hints may help.

- ◆ Check main facility input power to the test set.
- ◆ Check all control and switch settings.
- ◆ Check indicating lamps. (Spare lamps are available through Phenix Technologies.)
- ◆ Check Fuse F1
- ◆ Check operation of main power circuit breaker (CB1). Main Power lamp should be on.
- ◆ Check all plug connections, internal and external, on the test set.

### SPECIFIC PROBLEMS

#### 1. High voltage cannot be turned on?

- Emergency off has been pressed – pull switch button up.
- External interlock is open (SX1).
- Voltage Control dial is not in zero start position.
- Protection circuit (Overload Trip) is not Reset.
- Faulty HV On or Off switch.
- Faulty relay contacts.

#### 2. Voltage control inoperable?

- Problem with power cable between Controls and High Voltage Unit.
- High voltage is not on (K1 or K3 not energized or see number 1 above).
- Faulty regulator "T1".
- Faulty step-up transformer in high voltage unit. (T301)

#### 3. Overload Trip inoperable?

- Improper sensitivity (adjust Current Trip (R15) on front panel).
- Defective U101, C-1, SCR 101 (C-2).
- Check the +15 volts DC regulator (REG. 4) on PCB 1257, C-2 (TP5).
- Check LP4 (RESET) and relay K101 on PCB 1257, C-2.

#### 4. Currentmeter inoperable?

- Connection between currentmeter and high voltage test specimen return connected improperly.
- Meter damaged
- Faulty TX1 interconnect cable.
- Damaged or inoperative range switch or wiring.
- Faulty Circuit on PCB1257.

## TROUBLESHOOTING

### SPECIFIC PROBLEMS (Cont'd)

#### 5. Voltmeter inoperable?

- Faulty DX1 interconnect cable.
- Meter damaged
- No high voltage present at output electrode.
- No high voltage present at divider electrode.
- Damaged or inoperative Measurement Divider Switch.
- Faulty circuit on PCB1257.

#### 6. No output voltage from high voltage section?

- Defective metering circuit.
- No input to voltage regulator section, possible problems with K1 or K3, or regulator T1.
- Internal connection broken.
- High voltage winding of T301 or T302 short circuited.
- Refer also to 1 and 2 above.

## **SECTION 8: MECHANICAL MAINTENANCE**

### **General**

No solution or chemical stronger than an ordinary household cleaner should be applied to the cabinet area of this unit. Care must be used when cleaning the meter faces and console panel. Abrasives may remove printing and descriptive titles and scratch meter faces. When cleaning, always have unit disconnected from power source. Never attempt to clean inside the unit as the cleaning solution may cause damage to the electronic components.

### **Surface**

All surfaces are finished with heavy duty paints and will provide adequate protection against the elements in normal use. It is recommended that the finish be wiped down with nothing stronger than ordinary household cleaner for longer life and also for proper electrical operation of the unit. Also inspect all fabrication joints for oil leakage. If a leak is found, consult the Service Department at Phenix Technologies.

### **Control Box / Regulator Section**

At least once every year, the control assembly should be removed for inspection of the regulator assembly and other parts. If dust and dirt are present, cleaning with a dry brush and air hose should be sufficient. Inspect the voltage regulator contact surfaces for any signs of burning or wear. The brushes are the carbon type and are constructed to provide a 1/8" wide contact point. If they are worn down so as to be nearing (approximately) 1/32" at the wider part of the brush, they should be replaced.

The only other mechanical maintenance needed on the control box is that it be kept clean.

### **Transformer Oil Maintenance**

At time intervals, ranging from six months to one year, the oil purity (see next page) should be checked in the high voltage transformer to verify its reliability. If the transformer is subject to adverse weather conditions or an oil leak develops, the oil purity should be checked regularly.

## SECTION 9: CHECKING OIL PURITY

**NOTE:** Typical test data for the oil used by Phenix Technologies are provided at the end of this section.

1. The most reliable means of determining the purity of the oil in the field is to test the dielectric strength. Test sets for this purpose available on the market differ in design, particularly in the shape of the electrodes and the test container. Tests on samples from the same oil carried out with electrodes of different types give different breakdown values for the same distance between the electrodes. Oil test values should therefore always be accompanied by information about the type of test gap used. The most common types of test gaps are:

- a. Cylinder gap.
- b. Spheres, 12.5 m in diameter.
- c. Flat discs, 25 mm in diameter.
- d. Segments of spheres, 35 mm in diameter, radius of sphere 25 mm.

Phenix employs for field testing Gap C, flat discs, which is per ASTM specification D-877.

2. Regardless of which type of test gap is used, it is important that container and electrodes be well cleaned and dried before oil filling. Cleaning should be done per the instructions with the oil testing equipment.

3. Sample the oil both at the top and the bottom of the transformer, if possible. In general, with small (portable) transformers, it may not be practical to sample the bottom oil. Phenix recommends a minimum test level of 30 kV when using the ASTM D-877 test procedure. If the oil tests lower than this, consult Phenix Technologies' Service Department for recommendations. Generally, for small (portable) transformers with small oil volumes, draining and refilling with new or repurified oil will be recommended. If filtering is recommended, proceed as follows:

- a. Perform the purification of contaminated oil in a transformer by circulating the oil between the transformer and the purification plant, drawing off the oil at the base and returning it at the top of the transformer. If the oil is heated in the purification plant, a stratification of heated and unheated oil will take place in the transformer. As the different oil layers mix very little, the circulation of the oil quantity will be more effective, thus reducing the time needed for treatment of the oil. Circulation of the oil is carried on until oil tests indicate that the desired oil quality is obtained. After circulation, the oil level is adjusted in accordance with the instruction plate on the transformer to the correct level at the prevailing oil temperature.

- b. When making or changing connections, always fill the feed hose completely with oil before opening the bottom valve on the transformer. If this precaution is not taken, the air in the hose, which may have considerable volume, will be forced into the transformer with the oil stream.

**NOTE:** If air has been injected into the oil, it is recommended that a period of two days be allowed after completion of oil filling until energizing to allow the oil to absorb any occluded air or gas in the insulation.

### 4. Oil Specifications

Transformer oil is a high quality insulating oil specially refined and formulated to meet the exacting requirements of major electrical equipment manufacturers and users. It also meets Federal Specification VV-I-530a.

High quality mineral-based transformer oil is recommended as the insulating and cooling medium for oil-immersed transformers. It is also recommended for arc-forming apparatus such as switches, circuit breakers, tap changers, reclosers, and fuses. General Characteristics of transformer oil include:

## CHECKING OIL PURITY

### a. High Dielectric Strength:

Transformer Oil has high electrical insulating values as shown by their dielectric strengths of over 30,000 volts.

### b. Excellent Oxidation Stability:

Excellent oxidation stability and high resistance to sludging provide protection, particularly where high temperatures are likely to be encountered. These products are specially refined to ensure long time service with a minimum of maintenance.

### c. Freedom From Contaminants:

Absence of organic acids, corrosive sulfur, and other foreign materials, which might affect metals or insulation, ensures long life for the oil as well as the electrical units.

### d. High Interfacial Tension:

High interfacial tension shows the absence of soluble polar contaminants. Refinery sealed containers assure maintenance of purity in transit.

### e. Good Heat Transfer Properties:

Good circulation and rapid transfer of heat from the coils to the cooling fins are assured by low viscosities at all operating temperatures.

## Typical Test Data for Transformer Oil

TEST	METHOD	UNITS	SPECIFICATION
Moisture	ASTM D1533	Mg/kg	35 max
Color	ASTM D1500	ASTM	0.5 max
DDF (Power Factor) @100°C	ASTM D924	0.3 max	0.3 max
Breakdown voltage (2mm gap)	ASTM D1816	kV	35 min
Inhibitor Content	ASTM D2668	%w/w	0.30 max
Interfacial tension	ASTM D971	dynes/cm	40 min
Density @15°C	ASTM D1298	g/ml	0.91 max
Viscosity @ 100°C	ASTM D445	cSt	3.0 max
Viscosity @ 40°C	ASTM D445	cSt	12.0 max
Viscosity @ 0°C	ASTM D445	cSt	76.0 max
Refractive Index	ASTM 1218	Units	
Carbon N%	ASTM D2140	%	
Carbon A%	ASTM D2140	%	
Carbon P%	ASTM D2140	%	
Corrosive Sulfur	ASTM D1275B		Noncorrosive
PCBs – Detection Unit 1 mg/kg	ASTM D4059	mg/kg	Not Detected
Flash Point	ASTM D92	0°C	145 min

## SECTION 10: TRANSPORTING / STORAGE OF EQUIPMENT

In some instances there is a requirement for transporting the equipment from one location to another for on-site field testing. If such conditions prevail, the following precautions should be adhered to.

### 1. Control Box / Regulator Section

Anchor sufficiently to prevent movement during shipment and covered with a canvas or other protective covering to prevent damage during transport.

### 2. Interconnect Cables

Cover the connectors, both male and female ends, with a protective covering to prevent foreign matter from entering.

### 3. High Voltage Transformer Modules

Anchor sufficiently to prevent movement during transport and cover with a canvas or other protective covering to prevent damages during transport. Prior to operation, all insulating materials and bushings should be cleaned. Protective caps should be in place on connectors.

### 4. High Voltage Divider

Anchor sufficiently to prevent movement during transport and cover with a canvas or other protective covering to prevent damages during transport. Prior to operation, all insulating materials and bushings should be cleaned. Protective caps should be in place on connectors.

### 5. Transportation Carts

Anchor sufficiently to prevent movement during transport and cover with a canvas or other protective covering to prevent damages during transport.

### 6. High Voltage Electrodes

Anchor sufficiently to prevent movement during shipment and covered with a canvas or other protective covering to prevent damage during transport.

## STORAGE OF EQUIPMENT

If the equipment will be stored for a prolonged period, the following precautions are recommended.

1. The equipment should be covered and kept in a warm, dry environment (95% maximum humidity, 5 to 50 degrees C).
2. If the high voltage transformer is to be stored outdoors, it should be completely covered to prevent damage from environmental conditions.
3. In no case should the control box be stored outdoors, unless previously specified in the original purchase agreement.
4. Prior to placing the equipment back into operation, all aspects of the maintenance schedule should be strictly adhered to.



## SECTION 11: CIRCUIT DIAGRAM SYMBOLS

CIRCUIT DIAGRAM SYMBOLS  
SYMBOLS POUR SCHEMA DE CIRCUIT  
SYMBOLE ZU SCHEMA

REF	SYMBOL	DESCRIPTION	DESCRIPTION	BEMENKUNG
A		Amplifier	Unite d'amplificateur	Verstärker
ARSR		Surge Arrestor	Parafoudre	Ueberspannungsableiter
C		Capacitor	Condensateur	Kondensator
BSHG		Bushing	Traversee	Durchfuehung
C		Electrolytic Capacitor	Condensateur electrol	Eleckrolytik kondensator
F		Fuse	Fusible	Sicherung
CT		Current Transformer	Transformateur de Courant	Stromtransformer
CB		Circuit Breaker	Intérupteur	Unterbrecher
K		Relay, Contactor	Relais, Contacteur	Relais, Schütz
L		Inductor	Self	Drossel, Spule
MOT		Motor	Moteur	Motor
MOV		Movistor	Parafoudre	Movistor
NE		Neon	Parafoudre	Ueberspannungsableiter
LP		Lamp, Indicator	Lampe	Meldeleuchte
R		Resistor	Resistance	Widerstand
R		Variable Resistor	Resistance Variable	Widerstand
T		Transformer	Transformateur	Transformer
TB		Terminal Block	Borne	Løsbare Klemme
X		Connector	Prise de Courant	Steckverbindung
K		Relay Contact Normally Open	Contact Normalement Ouvert	Schlierskontakt
K		Relay Contact Normally Closed	Contact Normalement Ferme	Oeffnungskontakt
K		Changeover Contact	Contact de Changement	Umschaltkontakt
		Shielded Wire	Cable blindé	Abgeschirmetes Kabel
TR		Transistor	Transisteur	Transistor
M		Analog Meter	Instrument Analogue	Analog Meter
D		Diode	Diode	Diode
Z		Zener	Diode Zener	Zener
SCR		Thyristor	Thyristor	Thyristor
SW		Normally Open Maintained Switch	Interrupteur Normalement Maintenu Ouvert	Schrittschalter (Schliesser)
SW		Normally Closed Maintained Switch	Interrupteur Normalement Maintenu Ferme	Schrittschalter (Oeffner)
SW		Normally Closed Momentary Switch	Interrupteur Normalement Ferme Momentanement	Druckschalter (Oeffner)
SW		Normally Open Momentary Switch	Interrupteur Normalement Ouvert Momentanement	Druckschalter (Schliesser)
DP		Current Overload Device	Dispositif De Sür Intensité	UeberstromschutzEinheit

**SECTION 12: ELECTRICAL DIAGRAMS**

<b><u>Drawing Number</u></b>	<b><u>Description</u></b>
9602110	6CP200-10 System Diagram
7612110	Control and Regulator Schematic
7632110	HV Transformer Schematic
7662110	HV Divider Schematic
MREF-012	200kV Switchgear Test Set Assembly Details

## SECTION 13: PARTS ORDERING INFORMATION

Replacement parts are available from Phenix Technologies, Inc.

Changes to Phenix Technologies' products are sometimes made to accommodate improved components as they become available, and to give you the benefit of the latest technical improvements developed in our Engineering Department. It is, therefore, important when ordering parts to include the serial number of the unit as well as the part number of the replacement part.

When your purchase order is received at our office, a representative of Phenix Technologies will contact you to confirm the current price of the part being ordered. If a part you order has been replaced with a new or improved part, an Applications Engineer will contact you concerning any change in part number.

Send orders for replacement parts to:

Replacement Parts Department  
Phenix Technologies, Inc.  
75 Speicher Drive  
Accident, Maryland 21520

Ph: (301) 746-8118

Fax: (301) 895-

E-mail: [info@phenixtech.com](mailto:info@phenixtech.com)

## SECTION 14: RECOMMENDED SPARE PARTS

Phenix Technologies recommends that the customer purchase and stock the following parts for normal maintenance of the unit. The recommended quantity should be sufficient to support the unit during normal operation.

If the unit will be operated at an isolated site for an extended period or will be subjected to unusual stresses, a larger quantity of parts should be stocked as spares. In such a case, contact your Phenix Technologies' sales representative for a recommendation.

Current prices may be obtained by contacting the Parts Ordering Department at Phenix Technologies.

<u>Part Name</u>	<u>Computer Number</u>	<u>Recommended Quantity</u>
LCD Meter, KNS 3 ½ Digit DMO-66T	1506400	1
Lamps, 31-963.4, EAO 60V	1420150	5
Limit Switch, 2HBA190-1 (SW7)	1866005	1
Switch, Mom., 1 Pole, 31-121.025 EAO (HV on, HV off, Reset)	1860120	1
Fuse, 1 A, 3AG (F1, F2)	1603601	2
Rotary Switch –4P, 2-6 Pos.	1863042	1
Relay (K3)	1705460	1

## SECTION 15: 6CP200/100-10 PARTS LIST

Item	Part Number	Description	Quantity
<b>CONTROL/REGULATOR</b>			
CB1,CB2	1601332	2P CIRCUIT BREAKER	1
CON1	1151178	RECEPTACLE	1
CON1	1151183	HIGH CURRENT PINS, MALE	3
CON2	1151179	RECEPTACLE	1
CON2	1151185	HIGH CURRENT PINS, FEMALE	2
DX1	1151152	RECEPTACLE,	1
DX1	1151174	CONTACT PINS, FEMALE	2
F1, F2 (220 V)	1603601	FUSE	2
F1,F2	1603920	FUSEHOLDER	2
HANDLES	2101710	HANDLE	2
K3 (220 V)	1705462	CONTACTOR	1
LP1,SW10,SW11	1422153	LENS CLEAR	1
LP1	1423300	SOCKET	1
LP1-4,SW10	1420150	LAMP	4
M1	31126500	CM PROTECTION PCB	1
M1,M2	1506400	3 ½ DIGIT LCD	2
M2	31126501	VM PROTECTION PCB	1
MOV1 (220 V)	1606110	MOVISTOR	1
PCB1257	31125719	6CP200/100-10 CONTROL/METERING BD	1
R15	1761098	POTENTIOMETER	1
R15-DIAL	1355910	DIAL	1
R15 KNOB	1355101	KNOB	1
R15 -CAP	1355102	PEAKED CAP	1
R15-KNOB	1355905	KNOB	1
R16A-B	1710400	RESISTOR	2
SW2/ LP2	1422150	LENS, RED	1
SW2,3,4	1860120	SWITCH, 1 POLE	3
SW4/ LP4	1422148	LENS, BLUE	1
SW7	1866005	ROLLER SWITCH	1
SW3/ LP3	1422151	LENS, GREEN	1
SW5, SW9	1355310	KNOB	2
SW5	1863042	SWITCH.	1
SW8	1860900	LATCHING MUSHROOM BUTTON	1
SW8	1862905	SWITCH	1
SW9	1863048	SWITCH	1
SW11	1860260	SWITCH 1POLE	1
SX1	1151152	RECEPTACLE	1
SX1	1151174	PINS, FEMALE	2
SX1 CBL	1151162	CBL PLUG	1
SX1 CBL	1151176	PINS, MALE	2
SX1 CBL	1151186	CABLE CLAMP	1
T1	1890239	VARIABLE AUTO TRANSFORMER	1
T2	1896017	CONTROL POWER TRANSFORMER	1
TX1	1151158	RECEPTACLE	1
TX1	1151170	PINS, MALE	9
INPUT CBL	30110007	BK130 INPUT POWER CBL-30',10/3	1
GND CBL	30080008	GROUND CABLE, 10FT	1
GND CBL	30080019	GROUND CABLE, 30FT	2
RTN CBL	30080020	RTN CBL, 30FT, PLIER CLIP	1
DX1 CBL	30050015	DIVIDER INTERCONNECT CABLE	1
PWR CBL	30110008	BK130 PWR INTERCONNECT-20',10/2	1
TX1 CBL	30160001	20' ST-ST 6PR SHL'D CABLE ASSY	1

## PARTS LIST

Item	Part Number	Description	Quantity
<b>HIGH VOLTAGE MODULES</b>			
TMR1	1480120	PANEL MOUNT DIGITAL TIMER	1
MOV301-10 (220 V)	1606110	MOVISTOR	10
T301-302	3834-2690	PHENIX TRANSFORMER GO1-2690	2
CON3	1151178	RECEPTACLE	1
CON3	1151183	HIGH CURRENT PINS, MALE	2
CON4	1151179	RECEPTACLE	1
CON4	1151185	HIGH CURRENT PINS, FEMALE	3
CON4	1151184	FEMALE CONTACT PIN	1
D501-4	1780066	TRANZORB	4
R505A-B	1720250	RESISTOR	2
R507	1722570	RESISTOR	1
R508	1722087	RESISTOR	1
R509	1720600	RESISTOR	1
R510	1740195	RESISTOR	1
TX1	1151158	RECEPTACLE	1
TX1	1151170	PINS, MALE	8
X1-3, T1-2	1356310	MULTILAMM SOCKET	8
X1-3, T1-2	1356312	MULTILAMM PLUG	6
H1-2	1356214	MULTILAM JACK	2
H1-2	1356212	MULTILAM PLUG	2
BP GND	1351103	BINDING POST (GREEN)	1
BP GRD	1351104	BINDING POST (WHITE)	1
BP RTN	1351102	BINDING POST (RED)	1
BP SHORT	1351110	BINDING POST SHORTING BAR	1
CAPS	1151196	SEALING CAP	3
CBL	30110042	PARALLELING CABLE	1
SPG501-502	1605110	SPARK GAP	2
<b>HIGH VOLTAGE DIVIDER</b>			
DX1	1151152	RECEPTACLE	1
DX1	1151175	CONTACT PINS, FEMALE	3
GROUND	1351103	BINDING POST GREEN	1
C601-602	1090304	CAPACITOR	2
TB601	1156050	TERMINAL STRIP	1
NET2	1609990	NEON LAMP	1
	31128204	PCB 1282	1
<b>HV OFF TIMER</b>			
	1153915	PIN, FEMALE	4
	1153970	4 PIN PLUG, MALE	1
	1153960	4 PIN PLUG, FEMALE	1
	1153935	PIN MALE	2

## Section 16: RETURNED MATERIAL

If for any reason it should become necessary to return this equipment to the factory, the Service Department of Phenix Technologies, Inc. must be given the following information:

Name Plate Information

Model Number

Serial Number

Reason for Return

Cause of Defect

If Phenix Technologies, Inc. deems return of the part appropriate; it will then issue an "Authorization for Return."

If return is not deemed advisable, other inspection arrangements will be made.

**NOTE:** Material received at this plant without the proper authorization shall be held as "Customer's Property" with no service until such time as the proper steps have been taken.

Your cooperation is requested in order to ensure prompt service.

### SECTION 17: CUSTOMER COMMENTS/SUGGESTIONS

Phenix Technologies made significant efforts to ensure that the materials in this Operator's Manual are correct. If there are concerns or comments as you have used this information, Phenix Technologies appreciates any feedback.

Unit Serial Number:

Sect	Page(s)	Comment

Please return to Phenix Technologies, Engineering Department, 75 Speicher Drive, Accident, MD 21520 USA.

Phone: 1 (301) 746-8118, Fax 1 (301) 895-5570 or info@phenixtech.com