

DST942-6



Display size
37"-42"



Max load

480lb (218kg)
80lb (36kg per display)

Multi-Display Ceiling Mount with Six Telescoping Arms

FOR 37" TO 42" DISPLAYS

The DST942-6 Multi-Display Ceiling Mount includes telescoping arms that holds six displays evenly spaced in a circular configuration, helping you create the ideal multi display ceiling mounted solution. Each arm's adjustable depth allows the installer to set the spacing between each display to meet your application's needs. With 360° of swivel, and 0° to 20° of tilt, this mount creates the perfect viewing angle for any application. The mount has been designed with superior aesthetics in mind and provides a bottom cover, resulting in sleek and clutter-free cable management throughout the entire solution.

DST942-6's telescoping arms offer spacing flexibility, so you can find the perfect placement for your display.



Additional Features

- ✓ Universal mount fits displays with mounting patterns up to 730 x 405mm (28.75"W x 15.95"H)
- ✓ 0° to 20° of tilt and 360° of swivel at time of installation
- ✓ Arms telescope to allow for the desired display spacing
- ✓ Bottom cover provides aesthetically pleasing cable management
- ✓ Tri and Quad options also available

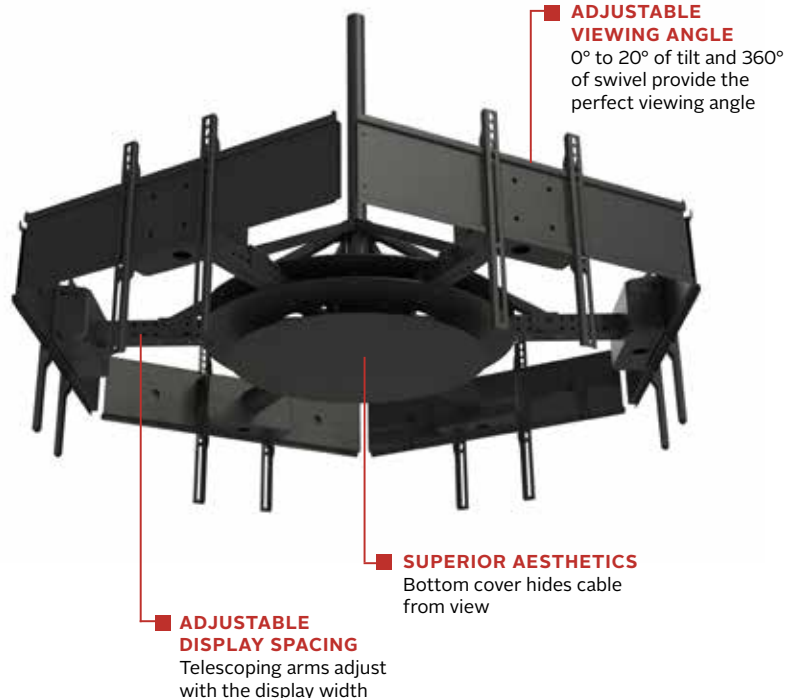

DST942-6 Multi-Display Ceiling Mount with Six Telescoping Arms for 37"-42" Displays

Product Specifications

	DIMENSIONS (W x H x D)	PRODUCT WEIGHT	LOAD CAPACITY	FINISH	AVAILABLE COLORS
DST942-6	56.40" x 21.80" x 56.40" (1433 x 554 x 1433mm)	186lb (84.5kg)	480lb (218kg) 80lb (36kg) per display	Matte/Flat	Black

Package Specifications

	PACKAGE SIZE (W x H x D)	PACKAGE SHIP WEIGHT	PACKAGE UPC CODE	PACKAGE CONTENTS	UNITS IN PACKAGE
DST942-6	52.00" x 32.00" x 12.00" (1321 x 813 x 305mm)	215lb (97.7kg)	735029302926	Mounting hub, telescoping arms, universal adaptor plate and mounting hardware	1

Accessories

ADD Models: Ceiling Extensions
DCS, DCT Models: Ceiling Plates

All dimensions = inch (mm)

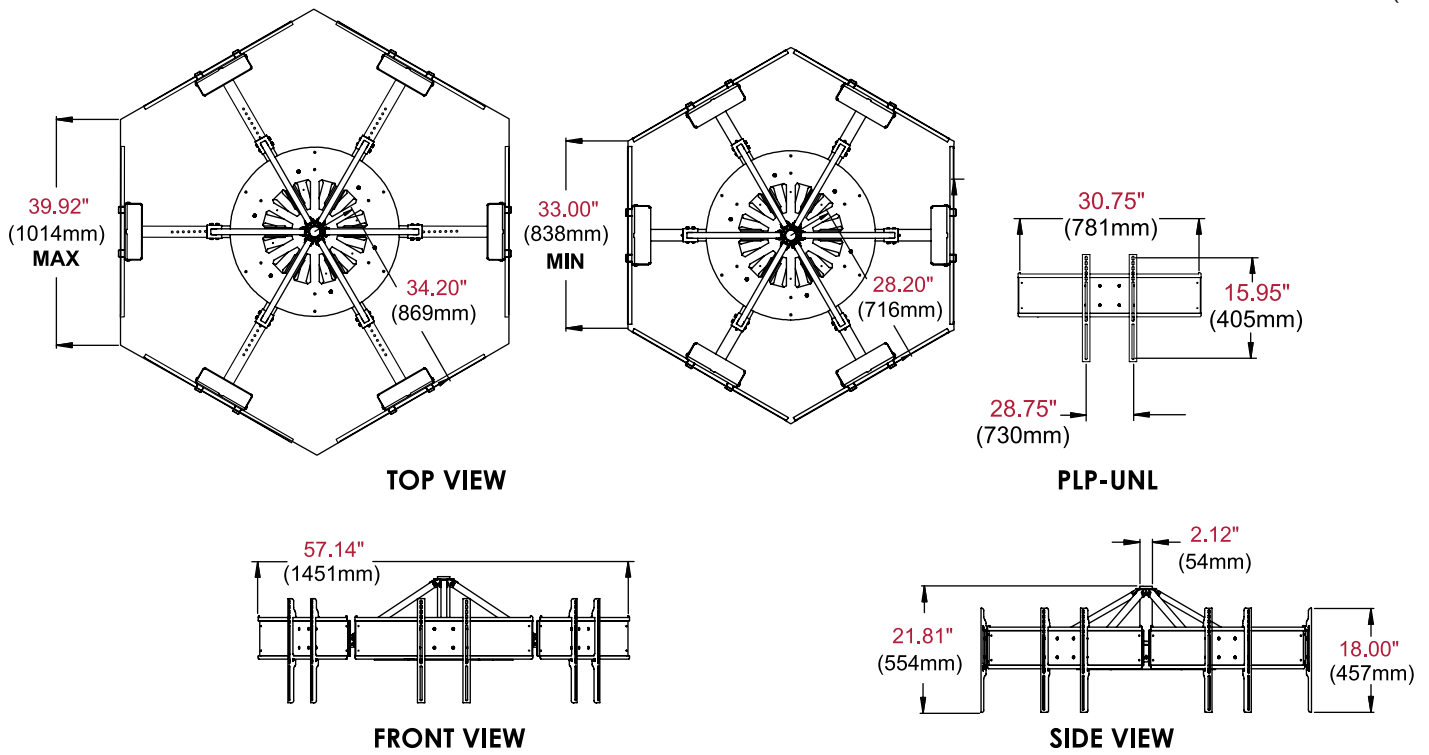

Architect Specifications

The Multi-Display Ceiling Mount with Six Telescoping Arms shall be a Peerless-AV model DST942-6 and shall be located where indicated on the plans. Assembly and installation shall be done according to instructions provided by the manufacturer.

Visit peerless-av.com to see the complete line of AV solutions from Peerless-AV, including outdoor displays, wireless, kiosks, digital audio, display mounts, projector mounts, carts/stands, and a full assortment of accessories.

Peerless-AV
2300 White Oak Circle
Aurora, IL 60502 USA
(800) 865-2112
(630) 375-5100
Fax: (800) 359-6500

Peerless-AV Europe
Unit 3 Watford Interchange
Colonial Way, Watford
Herts, WD24 4WP
United Kingdom
+44 (0) 1923 200100
Fax: +44 (0) 1923 200101

Peerless-AV de México
Ave de las Industrias 413
Parque Industrial Escobedo
Escobedo, N.L.,
Mexico 66050
+52 (81) 8384-8300
Fax: +52 (81) 8384-8360

