



**205 Westwood Ave, Long Branch, NJ 07740**  
**Phone: 866-94 BOARDS (26273) / (732)-222-1511**  
**Fax: (732)-222-7088 | E-mail: [sales@touchboards.com](mailto:sales@touchboards.com)**

LA1710R,  
LA1710RTR,  
LA1710RTS  
and LA1710RTC

## USER'S GUIDE

[www.planar.com](http://www.planar.com)

The information contained in this document is subject to change without notice. This document contains proprietary information that is protected by copyright. All rights are reserved. No part of this document may be reproduced, translated to another language or stored in a retrieval system, or transmitted by any means, electronic, mechanical, photocopying, recording, or otherwise, without prior written permission.

Windows is a registered trademark of Microsoft, Inc.

Other brands or product names are trademarks of their respective holders.

**European Union 2002/95/EC Directive on the Restriction of Hazardous Substances (RoHS)**

In February 2003, the European Union issued Directive 2002/95/EC on the Restriction of Hazardous Substances, commonly known as RoHS, in certain electrical and electronic equipment. It restricts the use of six hazardous substances, including lead (Pb).

The Directive states that all new products within its scope, placed on the European market after July 1, 2006 must be compliant with its requirements.

Planar Systems Inc. is fully in support of and compliant with EU Directive 2002/95/EC for applicable products within its scope.

A Planar part number will be modified with an "LF" suffix designation to indicate RoHS compliance, as shown on the part number label affixed to the display and on the box containing the display.

**Important Recycle Instruction:**



LCD Lamp(s) inside this product contain mercury. This product may contain other electronic waste that can be hazardous if not disposed of properly.

Recycle or dispose in accordance with local, state, or federal Laws. For more information, contact the Electronic Industries Alliance at [WWW.EIAE.ORG](http://WWW.EIAE.ORG).

For lamp specific disposal information check [WWW.LAMPRECYCLE.ORG](http://WWW.LAMPRECYCLE.ORG).

For more information on how to recycle your product, please visit

[WWW.PLANARSYSTEMS.COM/GREEN](http://WWW.PLANARSYSTEMS.COM/GREEN).

**Revision Control**

DATE:	DESCRIPTION:
March 2004	Document number 020-0320-00A
March 2005	Document number 020-0320-00B
June 2006	Document number 020-0320-01A
May 2008	Document number 020-0320-01B
May 2010	Document number 020-0320-02A
May 2011	Document number 020-0320-03A

---

---

# Table of Contents

## Usage Notice

Precautions .....	4
-------------------	---

## Introduction

About the Product .....	5
Package Overview .....	8

## Installation

Product Overview .....	9
------------------------	---

## User Controls

Front Panel Controls .....	13
How to Use the OSD Menus .....	14
On-Screen Display Menus .....	15

## Appendix

Troubleshooting .....	19
Warning Signal .....	20
Product Dimensions .....	21
Video Modes .....	24
Touch Screen Driver Installation .....	25
Support and Service .....	28

---

---

# Usage Notice



**WARNING** – To prevent the risk of fire or shock hazards, do not expose this product to rain or moisture.



**WARNING** – Please do not open or disassemble the product as this may cause electric shock.

## Precautions

Follow all warnings, precautions and maintenance as recommended in this user's guide to maximize the life of your unit.

### Do:

- Turn off the product before cleaning.
- LCD front surface may be cleaned using a soft clean cloth moistened with mild window glass commercial cleaners or 50/50 mixture of water and isopropyl alcohol.
- Use only high quality and safety approved AC/DC power adapter that comes with your monitor.
- Disconnect the power plug from AC outlet if the product is not used for an extended period of time.

### Don't:

- Do not touch the LCD display screen surface with sharp or hard objects.
- Do not use abrasive cleaners, waxes or solvents for cleaning.
- Do not operate the product under the following conditions:
  - Extremely hot, cold or humid environment.
  - Areas susceptible to excessive dust and dirt.
  - Near any appliance generating a strong magnetic field.
  - In direct sunlight.

---

---

# Introduction

## About Planar's LA1710R / LA1710RTR / LA1710RTS / LA1710RTC

The LA17 products all have a 17" flat panel screen with an active matrix, thin-film transistor (TFT) liquid crystal display (LCD).

### Features include:

- Dual signal input: Analog VGA and Digital DVI-D
- Active matrix TFT LCD technology
- 1280 x 1024 SXGA resolution
- 17" viewable display area
- 31 ~ 80 kHz horizontal scan
- 56 ~ 75 Hz refresh rate
- 0.264mm x 0.264mm pixel pitch
- 350 cd/m<sup>2</sup>(typ.) brightness
- 1000:1(typ.) contrast ratio
- L/R=85°/85°,U/D=85°/80° viewing angle, CR=10
- Tr+Tf = 5ms (typ.) response time
- 4 CCFL backlight lamps w/50,000 hrs life (typ.)
- Auto-adjustment function
- Multilingual OSD user controls
- VESA DPMS power saving
- Durable touch screen
- VESA rear mounting 100mm x 100mm standard

---

---

## Touch Screen for LA1710RTR

Resistive for finger interface

- Surface: Anti-glare treatment
- Interface: USB
- Durability: 35 million touches at a single point
- Hardness: 4H per ASTM D3363-92
- Operating force: Finger - < 50g average
- Transmissivity: 76% (typ.)
- Haze: 5%
- Clarity: 80%
- Driver: Windows® 7, Vista, XP, 2000, ME, 98, NT 4.0, CE, XP Embedded,  
Apple® Mac OS, Linux

## Touch Screen for LA1710RTS

Surface Acoustic Wave (SAW) touch screen for finger and stylus input

- Surface: Anti-glare treatment
- Interface: Dual RS-232 Serial/USB controller
- Durability: 50 million touches at a single point
- Hardness of surface: Mohs' Hardness rating of 7
- Operating force: Typically less than 85 g
- Transmittance: 92±5%
- Driver: Windows® 7, VISTA, XP, 2000, ME, 98, NT4.0, CE, XP Embedded,  
Linux, Apple® Mac OS

---

---

## Touch Screen for LA1710RTC

Capacitive for finger interface

- Surface: Anti-glare treatment
- Interface: USB
- Durability: 225 million touches in a single location
- Hardness: Cannot be scratched using any stylus with Mohs' rating of less than 6.5
- Transmissivity: 88%
- Driver: Windows® XP, Vista, Windows® 7, Linux

---

---

## Package Overview

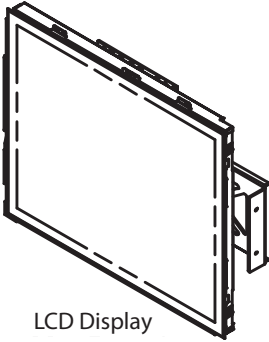

LCD Display

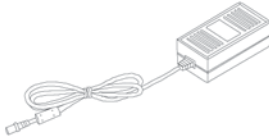

Power Adapter



Power Cord

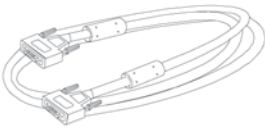

VGA Signal Cable



Landing Strip

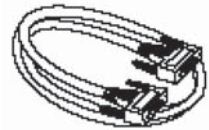

RS-232 Cable  
(for LA1710RTS only)



USB Cable  
(for LA1710RTR/  
LA1710RTC)

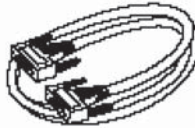

DVI Signal Cable

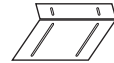

"L" Bracket, 2 pcs



---

---

# Installation

## Product Overview

- Front View

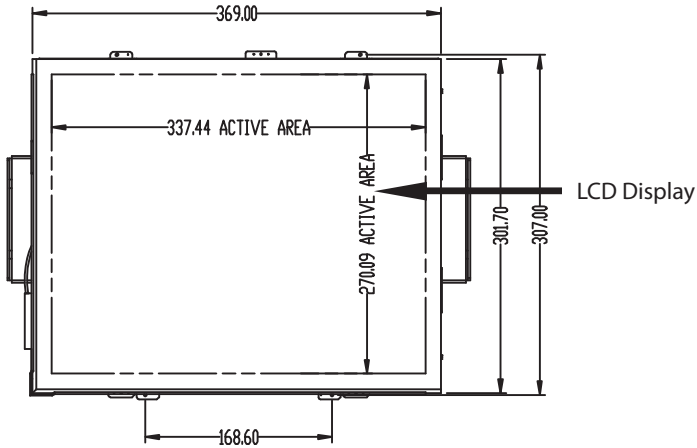

- Rear View

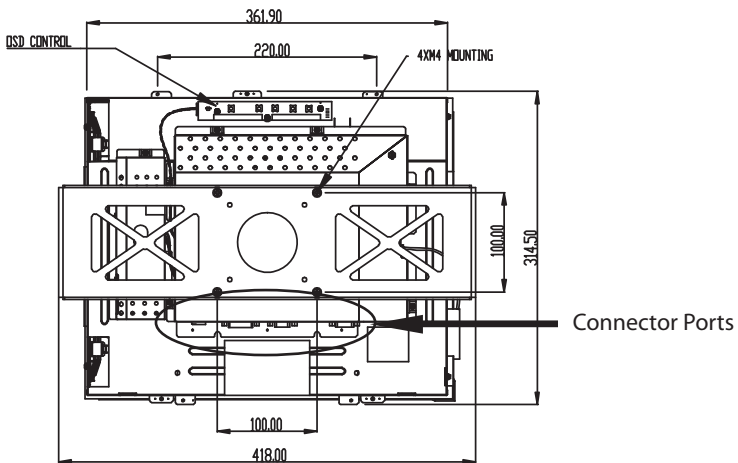

• Connector Ports

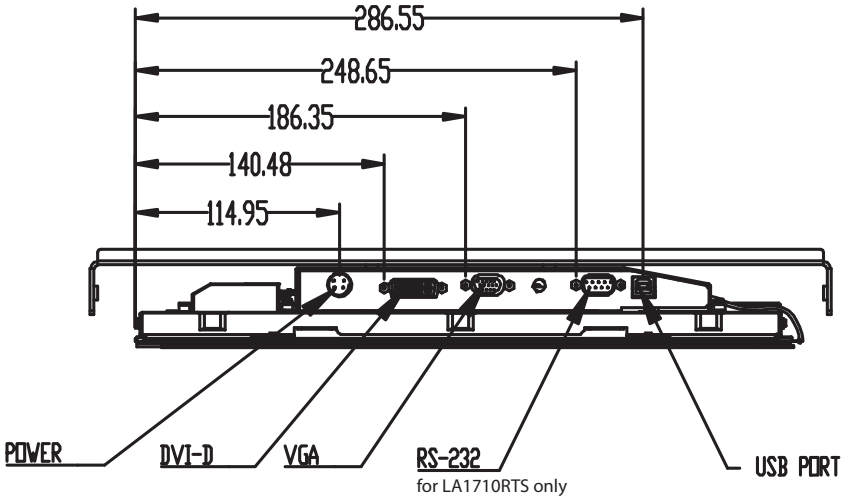

---

---

## Connecting the display (Figure 1.1)

To set up this display, please refer to the following figure and procedures.

1. Be sure all equipment is off.
2. Connect the DC power cord to the power connector. Plug one end of the AC power cord into the power adapter, and the other end into an electrical outlet(1).
3. For the PC with Analog graphics output: connect the VGA signal cable from display VGA input connector to the 15-pin connector of your host computer and tighten the screws(2).
4. For DVI-D output: connect DVI cable from display to the PC(2a).
5. For the LA1710RTR, LA1710RTS or the LA1710RTC touch screen models configure the touch screen. Refer to the "Touch Screen Driver Installation" section on page 25.
6. Turn on your computer, display and video source.

**Notice:** To ensure the LCD display works well with your computer, configure the display mode of your graphic card, less than or equal to 1280 x 1024 resolution and make sure the timing of the display mode is compatible with the LCD panel. "Video Modes" of this LCD panel are listed in the appendices for your reference.

Figure 1.1

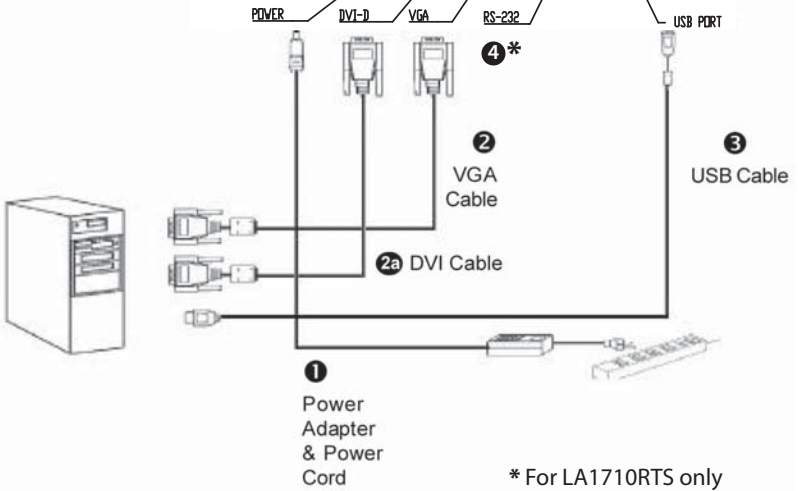
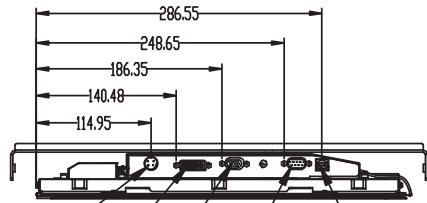
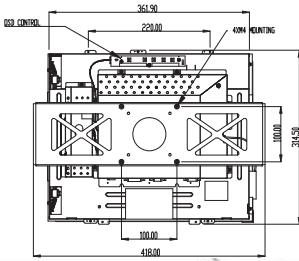





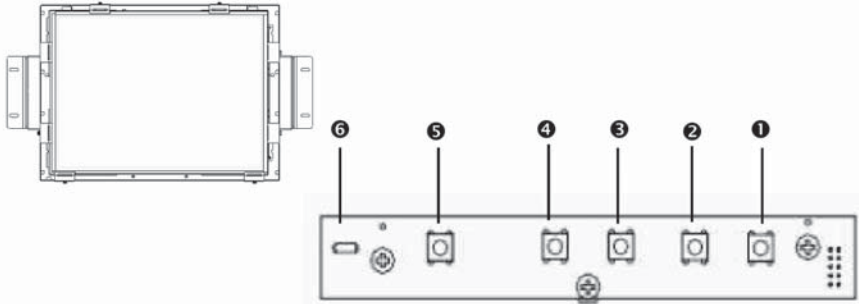

# User Controls

## Front Panel Controls



205 Westwood Ave, Long Branch, NJ 07740  
 Phone: 866-94 BOARDS (26273) / (732)-222-1511  
 Fax: (732)-222-7088 | E-mail: sales@touchboards.com



No./ Icon	Control	Function
1 	Menu button	Displays the OSD menus.
2 	Select / Auto	Select- To select the adjustment items from OSD menus. Auto- To activate the "Auto Adjustment" function to obtain an optimum image.
3 	Brightness Minus / Minus	1. Decreases the brightness of the display image. 2. Decreases value of the adjustment items.
4 	Brightness Plus / Plus	1. Increases the brightness of the display image. 2. Increases value of the adjustment items.
5 	Power Switch	Switches on/off the power of the LCD display.
6 	Power LED	1. Green indicates the display is turned on. 2. Amber indicates the display is in power-saving mode.

---

---

## How to Use the OSD Menu

1. Press the “Menu” button to pop up the on-screen menu and to select between the four main menus.
2. Choose the adjustment items by pressing the “Select/Auto” button.
3. Adjust the value of the adjustment items by pressing the “” button.
4. The OSD menu will automatically close, if you have left it idle for a pre-set amount of time.

---

---

## On-Screen Display Menus

First OSD Menu:

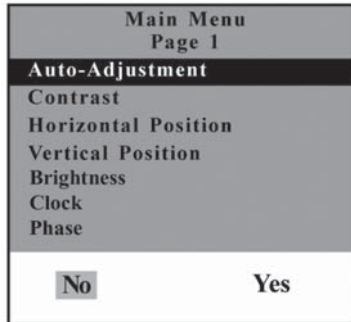

- ◆ **Auto-Adjustment**  
Choose this function to obtain an optimum image.
- ◆ **Contrast**  
This function allows the user to adjust the image crispness. Contrast adjusts the difference between white and black shades.
- ◆ **Horizontal Position**  
Changes the horizontal position of the image.
- ◆ **Vertical Position**  
Changes the vertical position of the image.
- ◆ **Clock**  
Changes the display data frequency to match the frequency of the graphic card. When you are experiencing vertical flickering bar, use this function to make an adjustment.
- ◆ **Phase**  
Synchronizes the signal timing of the display to that of the graphic card. When you are experiencing unstable to flickering image, use this function to make an adjustment.

---

---

## On-Screen Display Menus

Second OSD Menu:

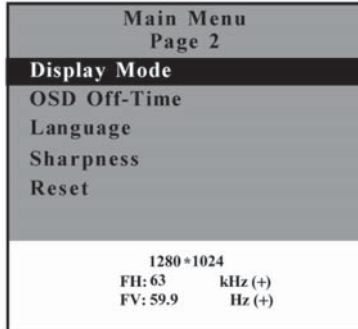

- ◆ **Display Mode**  
Select this function to view the display resolution, vertical refresh, and horizontal scan of the current mode.
- ◆ **OSD Off-Time**  
Adjusts the time it takes for the OSD menu to disappear.
- ◆ **Language**  
Choose the language you need.
- ◆ **Sharpness**  
Adjust the sharpness of the image.
- ◆ **Reset**  
Returns the display parameters of the current mode to the factory default settings.



---

---

## On-Screen Display Menus

Third OSD Menu:

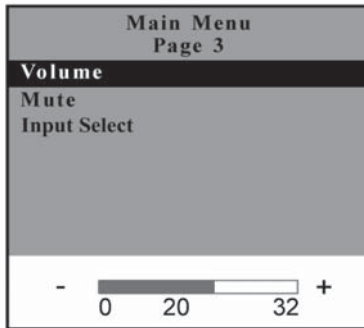

- ◆ **Volume**  
Controls the sound volume.  
**NOTE:** Audio functions disabled at factory.
- ◆ **Mute**  
Disables the sound immediately.
- ◆ **Input Select**  
Choose the input signal.

---

---

## On-Screen Display Menus

Fourth OSD Menu:



- ◆ **Color**  
Adjusts the color temperature.
- ◆ **Color Adjustment-Red**  
Adjusts the red color of the display.
- ◆ **Color Adjustment-Green**  
Adjusts the green color of the display.
- ◆ **Color Adjustment-Blue**  
Adjusts the blue color of the display.

---

---

# Appendix

## Troubleshooting

If you are experiencing trouble with the LCD display, refer to the following. If the problem persists, please contact your local dealer or visit Planar Support at [www.planar.com/support](http://www.planar.com/support). See support contact information on rear cover.

### **Problem: No image appears on screen.**

- ◆ Check that all the I/O and power connectors are installed correctly and well connected as described in the "Installation" section.
- ◆ Make sure the pins of the connectors are not crooked or broken.
- ◆ Reconfigure the resolution of your computer to make it less than or equal to 1280 x 1024.

### **Problem: Partial image or incorrectly displayed image.**

- ◆ Check to see if the resolution of your computer is higher than that of the LCD display.
- ◆ Reconfigure the resolution of your computer to make it less than or equal to 1280 x 1024.

### **Problem: Image has flickering vertical line bars.**

- ◆ Use "Clock" to make an adjustment.
- ◆ Check and reconfigure the display mode of the vertical refresh rate of your graphic card to make it compatible with the LCD display.

### **Problem: Image is unstable and flickering**

- ◆ Use "Phase" to make an adjustment.

### **Problem: Image is scrolling**

- ◆ Check and make sure the VGA signal cable (or adapter) is well connected.
- ◆ Check and reconfigure the display mode of the vertical refresh rate of your graphic card to make it compatible with the LCD display.

### **Problem: Ghosting image (characters and graphics)**

- ◆ Use "Clock" to make an adjustment. If the problem persists, use "Phase" to make an adjustment.

---

---

## Warning Signal

If you see warning messages on your LCD screen, this means that the LCD display cannot receive a clean signal from the computer graphics card.

There may be three sources for this problem. Please check the cable connections or contact Planar for more information.

◆ **No Signal**

This message means that the LCD display has been powered on but it cannot receive any signal from the computer graphic card. Check all the power switches, power cables, and VGA signal cable.

◆ **Going to Sleep**

This message means that the LCD display is under the power saving mode. In addition, the LCD display will enter the sleeping mode when experiencing a sudden signal disconnecting problem.

◆ **Out of Range**

This message means that the signal of the computer graphic card is not compatible with the LCD display. When the signal is not included in the "Video Modes" list we have listed in the Appendices of this manual, the LCD display will display this message.

---

---

## Product Dimensions

LA1710R, LA1710RTR, LA1710RTS and LA1710RTC - Front View:

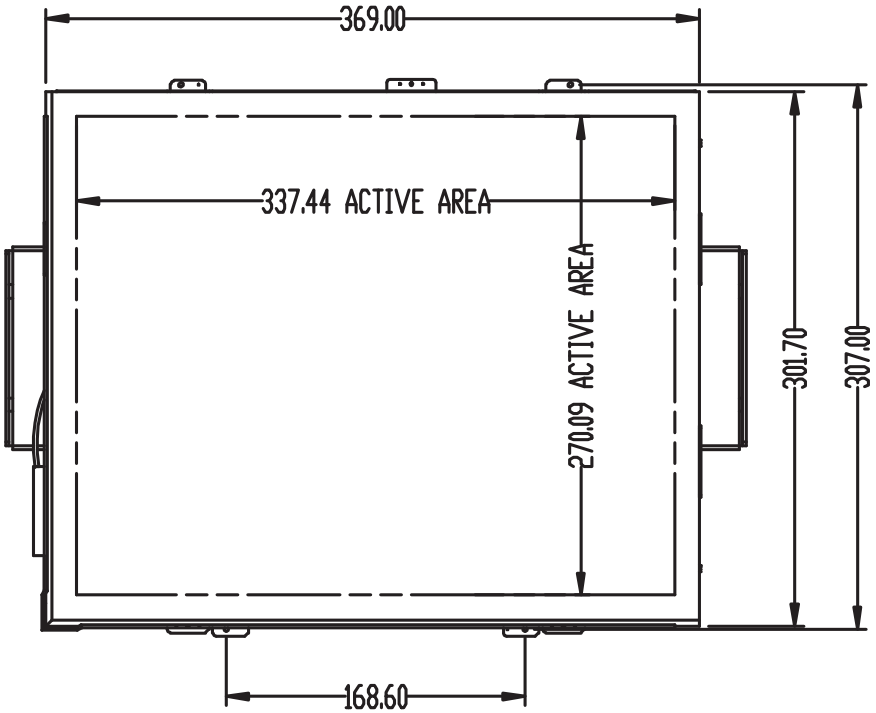

LA1710R, LA1710RTR, LA1710RTS and LA1710RTC - Side View:

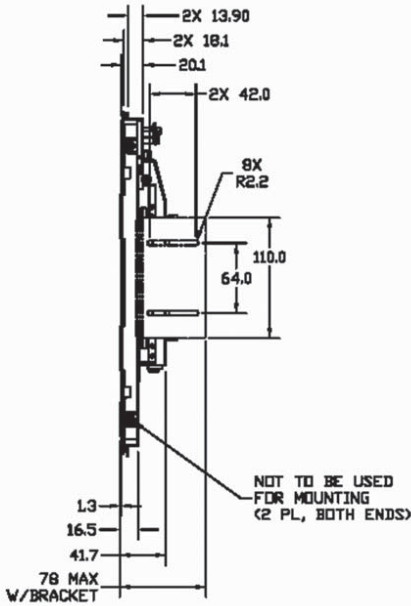

LA1710R (non touch)

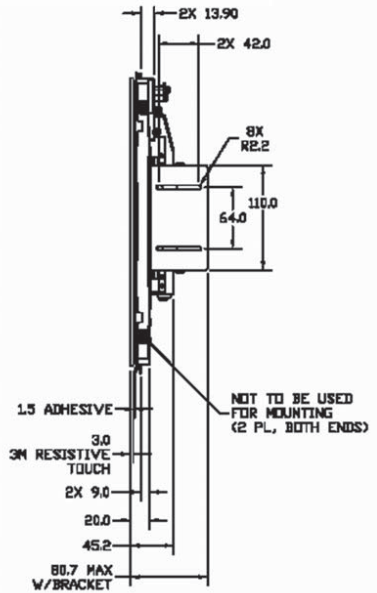

LA1710RTR (resistive touch)

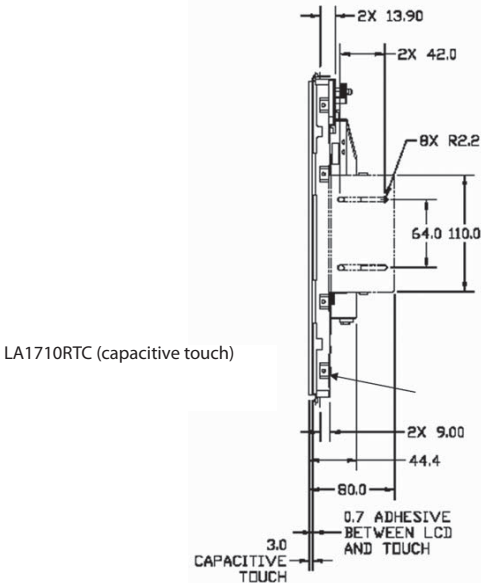

LA1710RTC (capacitive touch)

LA1710R, LA1710RTR, LA1710RTS and LA1710RTC - Rear View:

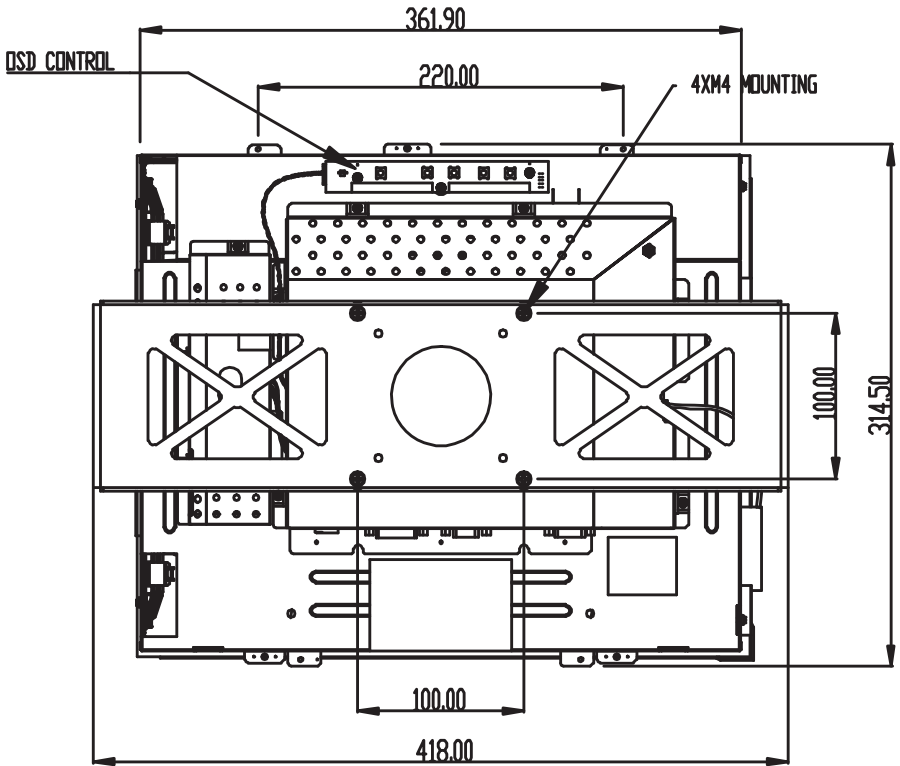

---

---

## Video Modes

The monitor supports the following industry-standard combinations of screen resolution and refresh rates. Other combinations are possible, but may require adjustments to the image.

For the optimal performance, set your computer to a screen resolution of 1024 x 768 at a 60 Hz refresh rate.

Display Mode		Hsync (kHz)	Vsync (Hz)
VGA	640 x 350	31.5	70
	640 x 480	31.5	60
		37.9	72
		37.5	75
SVGA	800 x 600	35.2	56
		37.9	60
		48.1	72
		46.9	75
XGA	1024 x 768	48.4	60
		56.5	70
		60	75
SXGA	1280 x 1024	64.0	60
		80.0	75
US TEXT	720 x 400	31.5	70
Apple MAC	640 x 480	34.9	67
		35	67
	832 x 624	49.7	75
	1024 x 768	60.2	75



---

---

## Touch Screen Driver Installation

### **Driver Installation for LA1710RTC: Capacitive Touch screen with USB Connection (MicroTouch™ Driver)**

Touch driver information is located at [www.planar.com/support](http://www.planar.com/support) for the following operating systems: **Microsoft Windows® XP, Windows® Vista, and Windows® 7.**

1. Be sure that the USB cable is not connected to the PC.
2. Click the "LA1710RTC, Win XP, Vista, Win 7" link.
3. Click "I accept" when the software license screen appears.
4. Follow the step-by-step instructions.
5. Reconnect the USB cable to the computer prior to use.
6. If the touch screen driver does not automatically load, restart the computer operating system.

**Please read "Readme.txt" located in the unzipped file folder for additional information and assistance.**

### **Linux Driver Installation for LA1710RTC: Capacitive Touch screen with USB Connection**

Touch driver information is located at [www.planar.com/support](http://www.planar.com/support). Supported platforms include: **Red Hat® Linux 8.0, Red Hat® Linux 9.0, and SuSE® Linux 8.2 and SuSE® Linux 9.0 on Pentium®-compatible CPUs. The following Xfree86 versions are supported: 4.0.3 and 4.1.0.**

1. Click the "LA1500RTR, LA1710RTR, LA1710RTC, Linux" link.
2. Click "I accept" when the software license screen appears.
3. Follow the step-by-step instructions.
4. If the touch screen driver does not automatically load, restart the computer operating system.

**Please read "Readme.txt" located in the unzipped file folder for additional information and assistance.**

---

---

## Driver Installation for LA1710RTR: Resistive Touch screen with USB Connection (TouchKit Driver)

The LA1710RTR is available with USB connection. The touch driver is located at [www.planar.com/support](http://www.planar.com/support) for these operating systems: **Windows® 7, VISTA, XP, 2000, ME, 98, NT 4.0, CE, XP Embedded, Linux, Apple® Mac OS.**

**Please Note:** The LA1710RTR is Microsoft® Windows® HID (Human Interface Device) compatible if you use the USB touch screen interface. No additional software driver is required for general operation of the touch screen. A calibration tool can be installed for improved touch position accuracy. See “Optional Calibration Tool Install” section for more information.

### LA1710RTR Optional Calibration Tool Install

If you would like to use the Optional Calibration Tool, follow the instructions below. Please note: **the calibration tool supports Windows® 7, VISTA, XP, and 2000 operating systems via USB only.**

1. Select the monitor size and then model name.
2. Click on the “Load Utility” button that appears to the right of the model name.
3. The HID calibration tool will automatically open. From here the user can choose to do the following:
  - a. 4 Points Calibration
  - b. 9 Points Linearization
  - c. 25 Points Linearization
  - d. Clear
  - e. Draw Test
  - f. Advanced. In the Advanced settings area the user may do the following:
    - i. Adjust the Double Click Area.
    - ii. Enable auto right click and adjust the auto right click time.
    - iii. Choose to be either in the HID Mouse Mode or HID Digitizer Mode
    - iv. Simply click the “Apply” button once the settings are finalized.

---

---

## LA1710RTR Install Instructions

**If you are using a PC running Windows® 7, VISTA, XP, 2000, ME, 98, NT4.0, follow the instructions below:**

1. Power on the PC.
2. Be sure the USB cable is connected from the PC to the LCD display.
3. Follow the step-by-step instructions as shown on the pop-up windows.

**If you are using a PC running Windows® XP Embedded, follow the instructions below:**

**Express:**

1. Power on the computer.
2. Make sure that the USB cable is connected to the computer.
3. Make sure that your EWF is disabled. If your EWF is enabled, please disable the EWF by using the EWF Manager command.
4. Once the EWF is disabled click on the XP driver at [www.planar.com/support](http://www.planar.com/support) and follow the step-by-step instructions as shown on the pop-up windows.

**Custom:**

1. Power on the computer.
2. Make sure that the USB cable is connected to the computer.
3. Follow the step-by-step instructions found in the zipped file at [www.planar.com/support](http://www.planar.com/support).

**If you are using a PC running Windows® CE, follow the instructions below:**

1. Power on the computer.
2. Make sure that the USB cable is connected to the computer.
3. Using Platform Builder, build an image file by following the step-by-step instructions found in the zipped file at [www.planar.com/support](http://www.planar.com/support).

**If you are using a PC running Linux or Apple® Mac OS, follow the instructions below:**

1. Power on the computer.
2. Make sure that the USB cable is connected to the computer.
3. Follow the step-by-step instructions found in the zipped file at [www.planar.com/support](http://www.planar.com/support).

---

---

## **Driver Installation for LA1710RTS: SAW Touch screen with RS232 and USB Connections (TouchKit Driver)**

The LA1710RTS is available with both RS232 and USB connections. The touch driver is located at [www.planar.com/support](http://www.planar.com/support) for these operating systems: **Windows® 7, VISTA, XP, 2000, ME, 98, NT 4.0, CE, XP Embedded, Linux, Apple® Mac OS.**

**Please Note:** The LA1710RTS is Microsoft® Windows® HID (Human Interface Device) compatible if you use the USB touch screen interface. No additional software driver is required for general operation of the touch screen. A calibration tool can be installed for improved touch position accuracy. See “Optional Calibration Tool Install” section for more information.

### **LA1710RTS Optional Calibration Tool Install**

If you would like to use the Optional Calibration Tool, follow the instructions below. Please note: **the calibration tool supports Windows® 7, VISTA, XP, and 2000 operating systems via USB only.**

1. Select the monitor size and then model name.
2. Click on the “Load Utility” button that appears to the right of the model name.
3. The HID calibration tool will automatically open. From here the user can choose to do the following:
  - a. 4 Points Calibration
  - b. 9 Points Linearization
  - c. 25 Points Linearization
  - d. Clear
  - e. Draw Test
  - f. Advanced. In the Advanced settings area the user may do the following:
    - i. Adjust the Double Click Area.
    - ii. Enable auto right click and adjust the auto right click time.
    - iii. Choose to be either in the HID Mouse Mode or HID Digitizer Mode
    - iv. Simply click the “Apply” button once the settings are finalized.

---

---

## LA1710RTS Install Instructions

**If you are using a PC running Windows® 7, VISTA, XP, 2000, ME, 98, NT4.0, follow the instructions below:**

1. Power on the PC.
2. Be sure the USB or the RS-232 Serial cable is connected from the PC to the LCD display.
3. Follow the step-by-step instructions as shown on the pop-up windows.

**If you are using a PC running Windows® XP Embedded, follow the instructions below:**

**Express:**

1. Power on the computer.
2. Make sure that the RS232 or USB cable is connected to the computer.
3. Make sure that your EWF is disabled. If your EWF is enabled, please disable the EWF by using the EWF Manager command.
4. Once the EWF is disabled click on the XP driver at [www.planar.com/support](http://www.planar.com/support) and follow the step-by-step instructions as shown on the pop-up windows.

**Custom:**

1. Power on the computer.
2. Make sure that the RS232 or USB cable is connected to the computer.
3. Follow the step-by-step instructions found in the zipped file at [www.planar.com/support](http://www.planar.com/support).

**If you are using a PC running Windows® CE, follow the instructions below:**

1. Power on the computer.
2. Make sure that the RS232 or USB cable is connected to the computer.
3. Using Platform Builder, build an image file by following the step-by-step instructions found in the zipped file at [www.planar.com/support](http://www.planar.com/support).

**If you are using a PC running Linux or Apple® Mac OS, follow the instructions below:**

1. Power on the computer.
2. Make sure that the RS232 or USB cable is connected to the computer.
3. Follow the step-by-step instructions found in the zipped file at [www.planar.com/support](http://www.planar.com/support).

---

---

**When changing the Touch Interface (RS-232 or USB),  
please follow the instructions below:**

1. Uninstall the touch driver.
2. Re-start the computer.
3. Remove the original Touch Interface (RS-232 or USB).
4. Connect the computer to the Touch Interface (RS-232 or USB) that you would like to use.
5. Load the touch driver found at [www.planar.com/support](http://www.planar.com/support), and then follow the step-by-step instructions as shown on monitor.

***PLEASE NOTE!***

***Don't plug in both the RS-232 and USB cables!***

***Doing so may cause a driver conflict, making your touch screen inoperable.***

---

---

# Support and Service

Planar is a US company based in Beaverton, Oregon and Espoo, Finland with a worldwide sales distribution network.

Visit Planar at <http://www.planar.com/support> for product registration, operations manuals, line drawings, touch screen drivers, warranty information and access to Planar's Technical Library for online troubleshooting.

To speak with Planar Customer Support please have your model and serial number available and dial one of these numbers:

## **Americas Support**

Tel: 1-866-PLANAR1 (866-752-6271) or +1 503-748-5799  
Hours: M-F, 8am - 8pm Eastern Time | M-F, 5am - 5pm Pacific Time

## **Europe and Asia-Pacific Support**

Tel: +358-9-420-01  
Hours: M-F, 7am - 4pm CET

Toll or long distance charges may apply.



**205 Westwood Ave, Long Branch, NJ 07740**  
**Phone: 866-94 BOARDS (26273) / (732)-222-1511**  
**Fax: (732)-222-7088 | E-mail: [sales@touchboards.com](mailto:sales@touchboards.com)**

Planar Systems, Inc.  
Customer Service  
24x7 Online Technical Support: <http://www.planar.com/support>

Americas Support  
Tel: 1-866-PLANAR1 (866-752-6271) or +1 503-748-5799  
Hours: M-F, 8am - 8pm Eastern Time | M-F, 5am - 5pm Pacific Time

Europe and Asia-Pacific Support  
Tel: +358-9-420-01  
Hours: M-F, 7am - 4pm CET

© 2011 Planar Systems, Inc. 05/11 Planar is a registered trademark of Planar Systems, Inc.  
Other brands and names are the property of their respective owners.  
Technical information in this document is subject to change without notice.

Document No. 020-0320-03 Rev. A