

PLANAR



205 Westwood Ave, Long Branch, NJ 07740
Phone: 866-94 BOARDS (26273) / (732)-222-1511
Fax: (732)-222-7088 | E-mail: sales@touchboards.com

PRODUCT SPECIFICATION, LC2600R-C

1	PRODUCT OVERVIEW	3
1.1	SCOPE	3
1.2	PRODUCT VERSIONS	3
1.3	PRODUCT DESCRIPTION	3
1.4	MONITOR FUNCTIONS	4
2	GENERAL SPECIFICATIONS	6
2.1	PERFORMANCE CONDITIONS	6
2.2	ENVIRONMENTAL SPECIFICATIONS	6
2.3	REGULATORY COMPLIANCE.....	6
2.4	RELIABILITY.....	8
3	MECHANICAL SPECIFICATIONS	8
3.1	I/O CONNECTORS	8
3.2	PRODUCT LABEL.....	8
3.3	WEIGHTS AND MEASURES (NOMINAL).....	9
3.4	MECHANICAL DRAWING	9
4	ELECTRO OPTICAL SPECIFICATIONS	9
4.1	MONITOR VOLTAGE AND POWER.....	9
4.2	LCD MODULE	9
5	OPTICAL SPECIFICATIONS	10
5.1	GENERAL	10
5.2	COSMETIC DEFECTS ,VIEWING AREA.....	12
5.3	DISPLAY DEFECTS, VIEWING AREA	13
5.4	PC GRAPHICS INPUT COMPATIBILITY.....	15
6	SHIPPING AND PACKAGING.....	15
6.1	PACKAGE CONTENTS	15
7	MAINTENANCE.....	15
8	REVISION HISTORY	16
9	APPENDIX A.....	16

1 PRODUCT OVERVIEW

1.1 Scope

This document specifies the mechanical, electrical, and optical performance requirements of the LC2600R-C.

1.2 Product Versions

Planar P/N	Planar Model	UPC
997-6050-01LF	LC2600R-C	8 10689 06050 5

1.3 Product Description

The LC2600R-C is intended for use as a high bright, open frame, TFT LCD, full color monitor. The monitor is a 26" WXGA with a 16:9 aspect ratio. The LCD panel has been rotated 180 degrees to place the best vertical viewing characteristics in the 6 o'clock viewing position. The monitor accepts standard PC graphics DVI digital signal. Refer to the following block diagram for a general depiction of the product components.

1.3.1 Primary Functional Components

The open frame LCD monitor includes the following.

- LCD module with backlight
- Front cooling fan and ductwork

1.3.2 Block Diagram

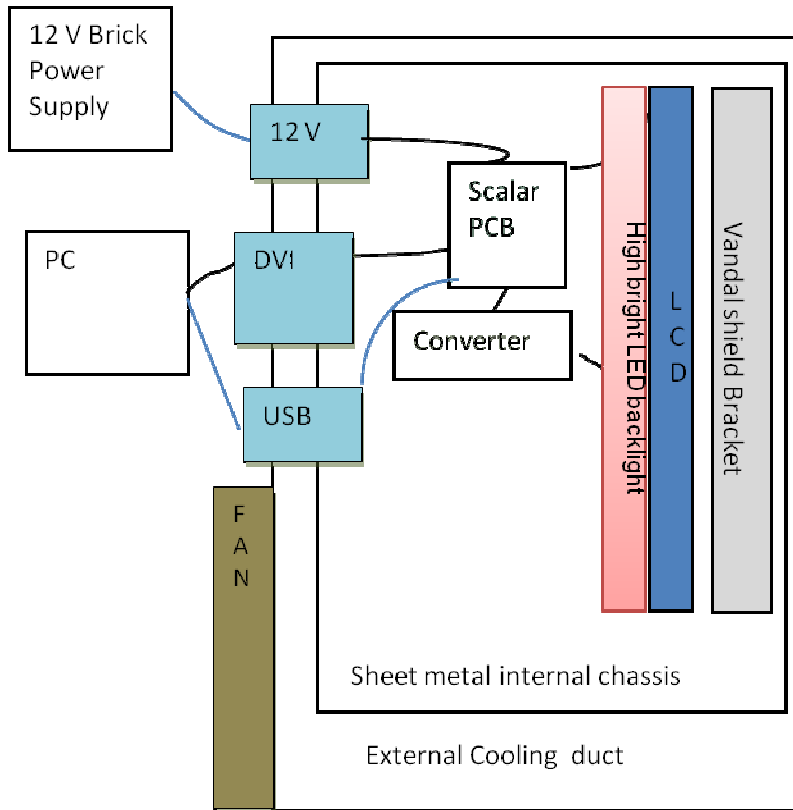

1.4 Monitor Functions

1.4.1 Auto-Dimming Mode

The monitor includes an auto-dimming function that automatically dims the monitor as ambient light conditions decrease. A light sensor mounted on the front of the display is used to measure ambient light.

1.4.2 Minimum Brightness Limit

The dimming circuit design allows the minimum brightness limit to be increased by the user if the default minimum is excessively low for the application. The adjustment is accomplished through the OSD.

1.4.3 Fan Control

The monitor has an external fan kit that cools the front of the LCD to reduce solar load heating. A temperature sensor on the front of the display senses the temperature near the front of the LCD and controls the fan speed.

1.4.4 OSD Connectivity

OSD functions can be accessed through buttons located on the back of the display or through USB. The table below summarizes the commands available through USB. Refer to Appendix A for details.

Command	Modes	Values
Power Status	Set, Get	ON = 0 STANDBY = 1 SUSPEND = 2 OFF = 3 SOFTPOWER = 4
Minimum Backlight Level	Set, Get ,Increment, Decrement	0-255
Contrast	Set, Get ,Increment, Decrement	64-192
Brightness	Set, Get ,Increment, Decrement	0-255
Color Temperature	Set, Get	9300K = 0 7500K = 1 6500K = 2 5500K = 3 USER1 = 4 LAST COLOR TEMP = 5
Gamma	Set, Get	LINEAR = 0 CRT = 1

2 General Specifications

2.1 Performance Conditions

Performance characteristics are guaranteed over the environmental specification range.

2.2 Environmental Specifications

2.2.1 Temperature and Humidity

Table 1: Environmental Conditions

Item	Description	Specification
1	Operating Condition	0 to 50 degree C, 20-80% non condensing RH
2	Storage Condition	-20 to 60 degree C, 80% maximum non condensing RH

2.2.2 Vibration & Shock

Note: Tests performed with assemblies mounted in a rigid retaining fixture.

- Random Vibration (Operating): 5-200 Hz, 1.46 G, 1 hour per axis (X, Y and Z)
- Sine Sweep Vibration (Non-Operating): 5-750 Hz, 1.0 G, half octave/min, 3 per axis (X, Y and Z)
- Shock (Operating): 20G, 11ms, sinusoidal shape, 3+ & 3- per axis (X, Y and Z)

Monitor will meet all performance and functional requirements contained in this specification after test exposure.

2.2.3 Shipping Box

Note: Tests performed monitor packaged in approved shipping carton

- Non-Operating Per ISTA 2A drop test
- Drop Height = 32 in
- Drop Position: 1 corner back right, 3 edges, and 6 faces

Monitor will meet all performance and functional requirements contained in this specification after test exposure.

2.3 Regulatory Compliance

2.3.1 Electromagnetic Compatibility (EMC)

Certification and test report demonstrating compliance to the following specifications is required.

2.3.1.1 Emissions

- 47 CFR. Part 15, Subpart B, Class A
- CE EMC Directive 2004/108/EC
- EN55022: 2006 +A1:2007, Class A
- EN610003-3-2:2006, Class D
- EN610003-3-3: 1995 +A1:2001 +A2:2005

2.3.1.2 Immunity Characteristics

- EN55024: 1998 +, A1:2001+, A2:2003
- IEC 61000-4-2:2008
- IEC 61000-4-3: 2008
- IEC 61000-4-4:2004
- IEC 61000-4-5: 2005
- IEC 61000-4-6: 2008
- IEC 61000-4-8: 2009
- IEC 61000-4-11:2004

2.3.2 Safety

Product will be compliant per EN60950-1 2nd Edition: 2005, UL 60950-1 and CSA 60950-1-3:2003.

2.3.3 CE Directive RoHS

Product will be compliant per Directive 2002/95/EC as amended by Commission Decision 2005/618/EC.

2.3.4 Product Agencies Marking

UL, CSA, TUV or other approved NRTL for U.S. and Canada, FCC Class A, CE.

2.3.5 Energy Compliance

- Australia & New Zealand Minimum Efficiency Performance Standards (MEPS) AS/NZS 4665
- EC Regulation No. 278/2009 No-load power consumption and average active power efficiency of external power supplies.

- EC Regulation No. 1275/2008 Standby and off mode power consumption of electrical and electronic household and office equipment.

2.4 Reliability

2.4.1 Overall Monitor MTBF

The target MTBF of the LC2600R-C is 40,000 hours at 25°C @ 45-55% RH, excluding brightness degradation. MTBF will be verified by test.

2.4.2 LED Backlight Life

Typical LED Backlight life is defined as 50,000 hours of continuous use at 25°C @ 45- 55% RH. End of life is defined when display luminance reaches 50% of initial typical brightness.

3 Mechanical Specifications

3.1 I/O Connectors

All external connections are located on the rear of the display.

3.1.1 Power Input

- Locking power connector.

3.1.2 OSD connectivity

- The monitor has a USB Type B connector for OSD connectivity.

3.1.3 PC Graphics

- DVI-I

3.2 Product Label

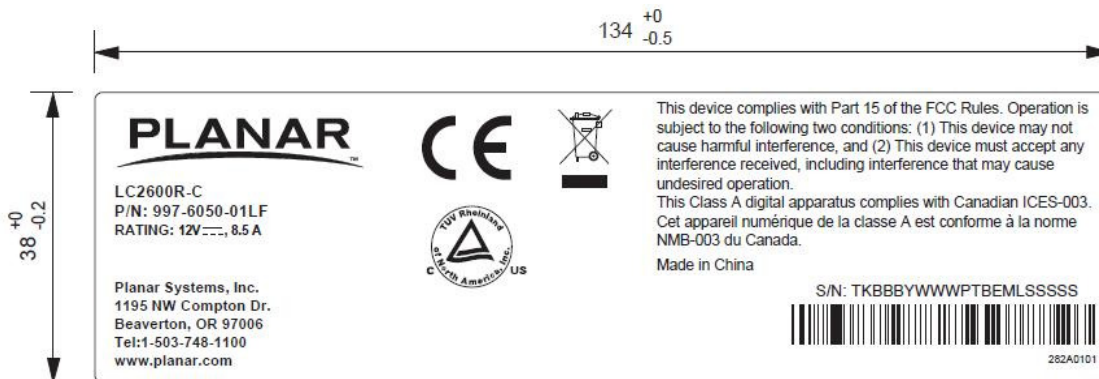

3.3 Weights and Measures (Nominal)

3.3.1 Base Weight (display and power adapter)

- 15.6 lb (7.1 kg)

3.3.2 Shipping Weight (display, power adapter, & packaging)

- 20.2 lb (9.2 kg)

3.3.3 Shipping Package Dimensions

- 28.5 in (724 mm)
- 8.0 in (203 mm)
- 19.8 in (503 mm)

3.3.4 Mounting Points

- 8-32 threaded insert side mounting holes. Reference drawing in section 3.4 for dimensions.

3.3.5 Connector Locations

- Reference drawing in section 3.4 for power, signal, and USB connector locations.

3.4 Mechanical Drawing

- Planar Drawing Reference 076-0681-01

4 Electro Optical Specifications

4.1 Monitor Voltage and Power

4.1.1 DC Voltage Input

- 12 ± 0.5 volts via external brick

4.1.2 DC Power Consumption

- Typical Power Load (W): 100
- Maximum Power Load (W): 120

4.2 LCD Module

Table 2: General Electro-Optical Specifications

Item	Description	Specification
1	Display active area (mm)	575.769 (H) x 323.712 (V) (26" Diagonal)
2	LCD manufacturer / Model	CMO / V260B2-L01
3	Display Colors	16.7 M Colors
4	Number of pixels	1366 x 768 R.G.B.
5	Pixel arrangement	RGB vertical stripe
6	Pixel pitch (mm)	0.4125 (H) x 0.4215 (V)
7	Display mode	Transmissive mode / Normally white
8	Surface Treatment	Anti-Glare Coating (Haze 25%) Hard coating (3H)
9	Backlight	White LED
10	Auto Adjustment	Yes
11	Input Video Signal	DVI
12	Image Re-Scaling	Automatic to Fill Screen
13	Display Response Time (Tr+Tf)	5 msec Typical @ 25 C

5 Optical Specifications

5.1 General

Table 3: Optical Specifications

Item	Description	Specification
1	Contrast Ratio	800:1 typical (500:1 min), normal to screen, center position
2	Luminance (Note 1)	<p>Typical: 1200 cd/m² , normal to screen, center position</p> <p>Minimum: 1000 cd/m² , normal to screen, center position</p> <p>Default minimum brightness limit set to 500 cd/m² , normal to screen, center position. Refer to Section 1.4.2 for details.</p>

3	Horizontal Viewing Angle	L/R: 80/80 deg @ CR 10:1 typical, normal to screen, center position
4	Vertical Viewing Angle (Note 2)	U: 70 deg @ CR 10:1 D: 80 deg @ CR 10:1 typical, normal to screen, center position
5	White Field Uniformity (Note 3)	Minimum of 5 points divided by Maximum of 5 points, result multiplied by 100, 70% typical
6	Color Gamut	70%, Typical value NTSC color gamut as defined by CIE 1931 color coordinates x, y

Note 1: Luminance at 100% ambient brightness.

Note 2: The LCD panel has been rotated 180 degrees to place the best vertical viewing angle in the 6 o'clock viewing position.

Note 3: Luminance uniformity measurement locations (center on left, 5 point on right).

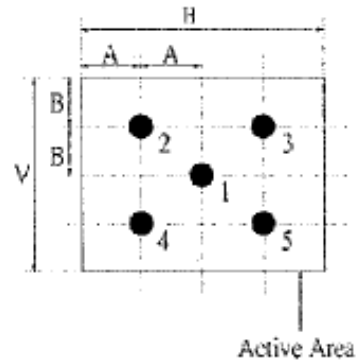
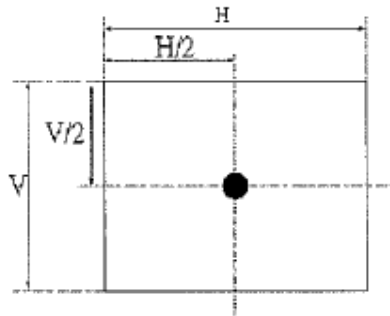

205 Westwood Ave, Long Branch, NJ 07740
 Phone: 866-94 BOARDS (26273) / (732)-222-1511
 Fax: (732)-222-7088 | E-mail: sales@touchboards.com

5.2 Cosmetic Defects ,Viewing Area

The following defect criteria apply to defects visible from at least 50 cm away from the display surface by the unaided eye with an ambient illumination of 400-600 Lux (fluorescent lighting).

These defects are those on the display surface or under the coatings where they may be visible during the normal use of the product.

Table 4: Cosmetic Visual Defects

Judge Area	Judge Item		Inspection Specification		Judge Criterion		
					Critical	Major	Minor
Active Area	Particles, scratch and bubbles in display area (Note 4)	Circular	Average Dia (D) mm		Numbers N		
			D < 0.15		Disregarded		
			0.15 ≤ D ≤ 0.8		N ≤ 5		
			0.8 < D		N = 0		
		Linear	Width W mm	Length L mm	Numbers N		
			W < 0.05 and L < 2		Disregarded		
			0.05 ≤ W ≤ 0.1 or 2 ≤ L ≤ 10		N ≤ 3		
			W > 0.1 or L > 10		N = 0		
						x	
						x	

Note 4: When L > 2W, defect is defined as linear type of defect

5.3 Display Defects, Viewing Area

These refer to defects caused by the electronic malfunction and defects in the active components. Specifically, these defects include partially or totally defective pixels, which would produce visible defects when using the displays.

It is important to note that the frequency of appearance of these defects, as well as the spacing between the defects must fall within the “acceptable” defect parameters range noted in Table 5.

These parameters are evaluated in Black, White, Red, Green, Blue screens.

Table 5: Screen Functional Defects

Item	Inspection Item	Specification
1	Line defect	None allowed
2	Bright dots	≤ 8 dots (note 5)
3	Green Bright dots	≤ 4 dots
4	Dark dots	≤ 8 dots
5	Total dots defect	≤ 10 dots
6	Adjacent Dot Defect (note 6)	Two continuous bright dots (vertical, horizontal, oblique): ≤ 2 pair
		Three or more continuous bright dots (vertical, horizontal, oblique): Not allowed
		Two continuous dark dots (vertical, horizontal, oblique): ≤ 2 pair
		Two continuous dots – one dark dot adjacent to one bright dot (vertical, horizontal, oblique): ≤ 2 pair
		Three or more continuous dots – to be of any combination of dark dot and bright dot (vertical, horizontal, oblique): Not allowed
		Distance between 2 B dots: ≥ 15mm Distance between 2 D dots: ≥ 15 mm Distance between B and D dots: ≥ 5mm

Note 5: Adjacent Dot Defect.

One pixel consists of 3 sub-pixels (R, G, and B). Sub-pixel=Dot

Note 6: Allowable adjacent defective dots

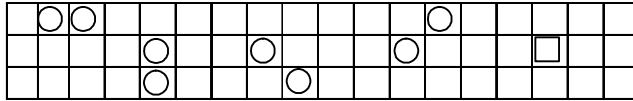

These defects count as two dots.

This is an example of a defective dot.

5.4 PC Graphics Input Compatibility

The LCD monitor has been tested to synchronize to, and scale, the following graphics inputs and generate a stable display that has a similar geometry.

Item	Description	Resolution	Vertical Refresh Rate
1	VESA VGA	640 x 480	60 Hz
2	VESA SVGA	800 X 600	60 Hz
3	VESA XGA	1024 x 768	60 Hz
4	VESA WXGA	1280 x 720	60 Hz
5	VESA WXGA (Native)	1366 x 768	60 Hz

6 Shipping and Packaging

6.1 Package Contents

Items Included:

- LC2600R-C LCD monitor: Qty. 1
- 12V DC 150 W Power Adapter: Qty. 1

7 Maintenance

The only routine maintenance may be occasional cleaning of the front LCD surface. This should be accomplished using a commercial glass cleaning solution or a mixture of 50% / 50% water and isopropyl alcohol mixture.

There are no field replaceable components.

8 Revision History

REV	ECO	DATE	SECTIONS	DESCRIPTION OF CHANGE
1	N/a		All	Preliminary Release
2	N/a	4-9-10	All	General update
A	1000508	4-30-10	All	General updates for release into PDM. Added picture of product label in section 3.2.
B	ECR-0000637	5-18-11	All	Updates for transferring production offshore.

9 Appendix A

All serial commands must be compatible with the Pixelworks PWHost protocol defined in the Pixelworks application note AN#77. Refer to AN #77 for protocol details.

The physical layer used for data exchange is a USB to serial port. The virtual serial port should be configured as follows:

Bits per second – 19200

Data bits – 8

Parity – None

Stop bits – 1

Flow control - None

An explanation of the content transmitted to the display...

Tx: [line 1] BE EF 03 19 00 HH HH II JJ JJ CC CC FF FF FF FF

Tx: [line 2] KK 00 00 00 CC CC CC CC CC CC CC CC CC CC CC

BE EF – signifies the beginning of the transmission (always BE EF)

03 – indicates the packet type (typically 03 in this application)

19 00 – indicates the packet length (typically 19 00 in this application)

HH HH – gives the calculated CRC checksum for the transmission

II – gives the operation type

JJ JJ – gives the operation name (least significant byte is on the left)

KK – gives the operation value

All CC, FF, or 00 – not applicable... always CC, FF or 00 as indicated

An explanation of the content received from the display...

Rx: [line 1] 1E BE EF 03 19 00 00 00 XX XX XX XX 00 FF FF FF

Rx: [line 2] FF KK 00 00 00 CC CC CC CC CC CC CC CC CC CC

Rx: [line 3] CC

1E -- is the acknowledgement indicating that the transmission has been successfully received

KK – gives the return value, if any, called for by the previous transmission

Everything else – “don’t care”

In the examples of data transmitted to the display and the responses from the display:

Operation names are **shown in blue**

Operation types are **shown in green**

Operation values, either transmitted or received, are **shown in red**

A. Power Command

Operation name: op_FORCE_DPMS_STATE

Operation types: SET or GET

Values:

dsON = LCD and inverter are powered on (inverter will power off if no video present)

dsSTANDBY = LCD and inverter off (state entered when no video Hsync is present)

dsSUSPEND = LCD and inverter off (state entered when no video Vsync is present)

dsOFF = if no video, LCD and inverter are powered off (will turn on when video returns)

dsSOFTPOWER = LCD and inverter are powered off regardless of video status

Factory default value: dsON

Typical uses:

Use dsON and dsSOFTPOWER to turn the display on and off, respectively.

-----Typical header file-----

```
op_FORCE_DPMS_STATE = 512 // 512 = x0200
```

```
typedef enum {
```

```
    dsON          = 0,
```

```
    dsSTANDBY    = 1,
```

```
    dsSUSPEND    = 2,
```

```
    dsOFF        = 3,
```

```
    dsSOFTPOWER  = 4,
```

```
} eDPMSSTATE;
```

-----Examples of data streams-----

op_Force_DPMS_State: turn on display

Tx: [0x000] BE EF 03 19 00 1B D8 01 00 02 CC CC FF FF FF FF

Tx: [0x010] 00 00 00 00 CC CC CC CC CC CC CC CC CC CC CC

Rx: [0x000] 1E BE EF 03 19 00 00 00 01 00 02 01 00 FF FF FF

Rx: [0x010] FF 00 00 00 00 CC CC CC CC CC CC CC CC CC CC

Rx: [0x020] CC

op_Force_DPMS_State: place display into Softpower state

Tx: [0x000] BE EF 03 19 00 D8 DA 01 00 02 CC CC FF FF FF FF

Tx: [0x010] 04 00 00 00 CC CC CC CC CC CC CC CC CC CC CC

Rx: [0x000] 1E BE EF 03 19 00 00 00 01 00 02 01 00 FF FF FF

Rx: [0x010] FF 04 00 00 00 CC CC CC CC CC CC CC CC CC CC

Rx: [0x020] CC

query op_Force_DPMS_State: result = display is in On state

Tx: [0x000] BE EF 03 19 00 50 27 02 00 02 CC CC FF FF FF FF

Tx: [0x010] 00 00 00 00 CC CC CC CC CC CC CC CC CC CC CC

Rx: [0x000] 1E BE EF 03 19 00 00 00 02 00 02 01 00 FF FF FF

Rx: [0x010] FF 00 00 00 00 CC CC CC CC CC CC CC CC CC CC

Rx: [0x020] CC

B. Minumim Backlight Brightness (controls minimum backlight intensity;)

Operation name: op_BACKLIGHT_LEVEL

Operation types: SET, GET, INCREMENT, or DECREMENT

eTarget: always = 0 (wnWIN_MAIN)

Values: _____ 0 to 255 valid

Factory default : 128

-----Typical header file-----

```
op_BACKLIGHT_LEVEL = 4097 = 0x1001
```

```
typedef enum {  
    wnWIN_MAIN          = 0,  
    wnWIN_PIP           = 1,  
    wnWINDOW_COUNT     = 2,  
    wnCURRENT_WINDOW   = 3,  
    wnINVALID_WINDOW   = 4,  
} eWINDOW;
```

-----Examples of data streams-----

```
set op_BACKLIGHT_LEVEL to 0xC8
```

```
Tx: [0x000] BE EF 03 19 00 6D 86 01 01 10 CC CC FF FF FF FF
```

```
Tx: [0x010] C8 00 00 00 CC CC CC CC CC CC CC CC CC CC CC CC
```

```
Rx: [0x000] 1E BE EF 03 19 00 00 00 01 01 10 01 00 FF FF FF
```

```
Rx: [0x010] FF C8 00 00 00 CC CC CC CC CC CC CC CC CC CC CC
```

```
Rx: [0x020] CC
```

increment op_BACKLIGHT_LEVEL

Tx: [0x000] BE EF 03 19 00 48 3F 03 01 10 CC CC FF FF FF FF

Tx: [0x010] CC CC CC CC CC CC CC CC CC CC CC CC CC CC CC CC

Rx: [0x000] 1E BE EF 03 19 00 00 00 03 01 10 01 00 FF FF FF

Rx: [0x010] FF CC CC CC CC CC CC CC CC CC CC CC CC CC CC CC

Rx: [0x020] CC

query op_BACKLIGHT_LEVEL: result = 0xC9

Tx: [0x000] BE EF 03 19 00 B0 2E 02 01 10 CC CC FF FF FF FF

Tx: [0x010] 00 00 00 00 CC CC CC CC CC CC CC CC CC CC CC CC

Rx: [0x000] 1E BE EF 03 19 00 00 00 02 01 10 01 00 FF FF FF

Rx: [0x010] FF C9 00 00 00 CC CC CC CC CC CC CC CC CC CC CC

Rx: [0x020] CC

C. Contrast Command

Operation name: op_CONTRAST

Operation types: SET, GET, INCREMENT, or DECREMENT

eTarget: always = 0 (wnWIN_MAIN)

Values: 64 to 192 (0x40 to 0xC0)

Factory default: 128

-----Typical header file-----

op_CONTRAST = 584 = 0x0248

```
typedef enum {  
    wnWIN_MAIN          = 0,  
    wnWIN_PIP           = 1,  
    wnWINDOW_COUNT     = 2,  
    wnCURRENT_WINDOW   = 3,  
    wnINVALID_WINDOW   = 4,  
} eWINDOW;
```

-----Examples of data streams-----

set op_CONTRAST to 0x6F

Tx: [0x000] BE EF 03 19 00 05 35 01 48 02 CC CC 00 00 00 00

Tx: [0x010] 6F 00 00 00 CC CC CC CC CC CC CC CC CC CC CC

Rx: [0x000] 1E BE EF 03 19 00 00 00 01 48 02 01 00 00 00 00

Rx: [0x010] 00 6F 00 00 00 CC CC CC CC CC CC CC CC CC CC

Rx: [0x020] CC

decrement op_CONTRAST

Tx: [0x000] BE EF 03 19 00 04 1C 04 48 02 CC CC 00 00 00 00

Tx: [0x010] CC CC CC CC CC CC CC CC CC CC CC CC CC CC CC CC

Rx: [0x000] 1E BE EF 03 19 00 00 00 04 48 02 01 00 00 00 00

Rx: [0x010] 00 CC CC CC CC CC CC CC CC CC CC CC CC CC CC

Rx: [0x020] CC

query op_CONTRAST: result = 0x6E

Tx: [0x000] BE EF 03 19 00 92 A7 02 48 02 CC CC 00 00 00 00

Tx: [0x010] 00 00 00 00 CC CC CC CC CC CC CC CC CC CC CC CC

Rx: [0x000] 1E BE EF 03 19 00 00 00 02 48 02 01 00 00 00 00

Rx: [0x010] 00 6E 00 00 00 CC CC CC CC CC CC CC CC CC CC CC

Rx: [0x020] CC

D. Brightness Command (controls color intensity; not a backlight control)

Operation name: op_BRIGHTNESS

Operation types: SET, GET, INCREMENT, or DECREMENT

eTarget: always = 0 (wnWIN_MAIN)

Values: _____ 0 to 255 valid

Factory default : 128

-----Typical header file-----

op_BRIGHTNESS = 583 = 0x0247

typedef enum {

wnWIN_MAIN = 0,

wnWIN_PIP = 1,

```
wnWINDOW_COUNT      = 2,  
wnCURRENT_WINDOW    = 3,  
wnINVALID_WINDOW    = 4,  
} eWINDOW;
```

-----Examples of data streams-----

set op_BRIGHTNESS to 0xC8

Tx: [0x000] BE EF 03 19 00 8F 7E 01 47 02 CC CC 00 00 00 00

Tx: [0x010] C8 00 00 00 CC CC CC CC CC CC CC CC CC CC CC CC

Rx: [0x000] 1E BE EF 03 19 00 00 00 01 47 02 01 00 00 00 00

Rx: [0x010] 00 C8 00 00 00 CC CC CC CC CC CC CC CC CC CC CC

Rx: [0x020] CC

increment op_BRIGHTNESS

Tx: [0x000] BE EF 03 19 00 AA C7 03 47 02 CC CC 00 00 00 00

Tx: [0x010] CC CC CC CC CC CC CC CC CC CC CC CC CC CC CC CC

Rx: [0x000] 1E BE EF 03 19 00 00 00 03 47 02 01 00 00 00 00

Rx: [0x010] 00 CC CC CC CC CC CC CC CC CC CC CC CC CC CC CC

Rx: [0x020] CC

query op_BRIGHTNESS: result = 0xC9

Tx: [0x000] BE EF 03 19 00 52 D6 02 47 02 CC CC 00 00 00 00

Tx: [0x010] 00 00 00 00 CC CC CC CC CC CC CC CC CC CC CC CC

Rx: [0x000] 1E BE EF 03 19 00 00 00 02 47 02 01 00 00 00 00

Rx: [0x010] 00 C9 00 00 00 CC CC CC CC CC CC CC CC CC CC CC

Rx: [0x020] CC

E. Color Temperature Command

Operation name: op_COLOR_TEMP

Operation types: SET or GET

Values: ct9300K, ct7300K, ct6500K, ct5000K

Factory default: ct7300K

-----Typical header file-----

```
op_COLOR_TEMP = 604 = 0x025C
```

```
typedef enum {
```

```
    ct9300K = 0,
```

```
    ct7300K = 1,
```

```
    ct6500K = 2,
```

```
    ct5000K = 3,
```

```
    ctUSER1 = 4,
```

```
    ctLASTCOLORTEMP = 5,
```

```
} eCOLORTEMPLIST;
```

-----Examples of data streams-----

set op_COLOR_TEMP = ct5000K

Tx: [0x000] BE EF 03 19 00 97 F2 01 5C 02 CC CC FF FF FF FF

Tx: [0x010] 03 00 00 00 CC CC CC CC CC CC CC CC CC CC CC CC

Rx: [0x000] 1E BE EF 03 19 00 00 00 01 5C 02 01 00 FF FF FF

Rx: [0x010] FF 03 00 00 00 CC CC CC CC CC CC CC CC CC CC CC

Rx: [0x020] CC

query op_COLOR_TEMP: result = ct5000K

Tx: [0x000] BE EF 03 19 00 2D 4D 02 5C 02 CC CC FF FF FF FF

Tx: [0x010] 00 00 00 00 CC CC CC CC CC CC CC CC CC CC CC CC

Rx: [0x000] 1E BE EF 03 19 00 00 00 02 5C 02 01 00 FF FF FF

Rx: [0x010] FF 03 00 00 00 CC CC CC CC CC CC CC CC CC CC CC

Rx: [0x020] CC

F. Gamma Command

Operation name: op_GAMMA_DISCRETE

Operation types: SET or GET

Values: gtLINEAR, gtCRT

Factory default: gtLINEAR

-----Typical header file-----

op_GAMMA_DISCRETE = 608 = 0x0260

typedef enum {

gtLINEAR = 0,

```
gtCRT = 1,  
} eGAMMATABLelist;  
-----Examples of data streams-----
```

```
set op_GAMMA_DISCRETE = gtLINEAR
```

```
Tx: [0x000] BE EF 03 19 00 A7 73 01 60 02 CC CC FF FF FF FF
```

```
Tx: [0x010] 00 00 00 00 CC CC CC CC CC CC CC CC CC CC CC CC
```

```
Rx: [0x000] 1E BE EF 03 19 00 00 00 01 60 02 01 00 FF FF FF
```

```
Rx: [0x010] FF 00 00 00 00 CC CC CC CC CC CC CC CC CC CC CC
```

```
Rx: [0x020] CC
```

```
set op_GAMMA_DISCRETE = gtCRT
```

```
Tx: [0x000] BE EF 03 19 00 37 B2 01 60 02 CC CC FF FF FF FF
```

```
Tx: [0x010] 01 00 00 00 CC CC CC CC CC CC CC CC CC CC CC CC
```

```
Rx: [0x000] 1E BE EF 03 19 00 00 00 01 60 02 01 00 FF FF FF
```

```
Rx: [0x010] FF 01 00 00 00 CC CC CC CC CC CC CC CC CC CC CC
```

```
Rx: [0x020] CC
```



205 Westwood Ave, Long Branch, NJ 07740
Phone: 866-94 BOARDS (26273) / (732)-222-1511
Fax: (732)-222-7088 | E-mail: sales@touchboards.com