



## Lightweight and Easy-To-Deploy

Leyard® CarbonLight™ is a comprehensive line of LED display solutions designed specifically for rental, staging and flexible-fixed installations. With a broad range of models, Leyard CarbonLight delivers a wide selection of unique LED display solutions for eye-catching, creative installations.

Leyard CarbonLight solutions share a patented carbon fiber construction that makes them uniquely lightweight, thin, strong and feature a refined mechanical construction for fast and flexible installations, as well as innovative features that deliver unique, eye-catching installations. Easily adapted to indoor, outdoor, hanging, floor-mounted, corner-beveled and even smoothly curved video walls, Leyard CarbonLight LED displays are unique in their thoughtful design and comprehensive range.

# Leyard CarbonLight Product Lines

Leyard CarbonLight includes five product lines with lightweight, flexible and easy-to-deploy LED display solutions that meet the unique needs of rental, staging or flexible-fixed environments.



## Leyard CarbonLight CLI Series Indoor LED Video Wall

The Leyard® CarbonLight™ CLI Series is a line of lightweight, flexible LED video wall displays, ideal for indoor rental, staging and flexible-fixed applications. The Leyard CarbonLight CLI Series' adaptable design is suitable for hanging and free-standing installations and features 45° edges to create 90° corners.

### FEATURES

- Available in 1.9, 2.6, 3.9 and 5.2mm pixel pitches
- Front and rear service models available
- Lightweight carbon fiber construction
- Compatible for hanging or free-standing installations
- Display size: 500 x 500 x 53mm

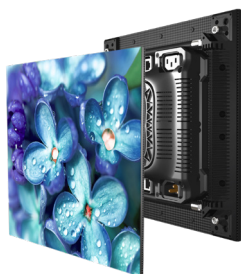

## Leyard CarbonLight CLA Series LED Video Wall

The Leyard® CarbonLight™ CLA Series is a line of LED video wall displays using Leyard® PrecisionArc™ alignment technology to create stunningly seamless installations with concave, convex or wave formations for rental, staging and flexible-fixed applications.

### FEATURES

- Available in 1.5 and 1.9mm pixel pitches
- Leyard PrecisionArc alignment technology for seamless concave, convex and wave shapes
- Lightweight carbon fiber construction
- Compatible for hanging or free-standing
- Display size: 250 x 250 x 58mm



## Leyard CarbonLight CLO Series Outdoor LED Video Wall

The Leyard® CarbonLight™ CLO Series is a line of LED video wall displays ideal for outdoor rental, staging and flexible-fixed applications. Each lightweight display is suitable for hanging and free-standing installations. The Leyard CarbonLight CLO Series' adaptable design features 45° edges to create 90° corners to enhance outdoor installation capabilities.

### FEATURES

- Available in 3.9, 5.2 and 7.8mm pixel pitches
- Ideal for outdoor applications
- Lightweight carbon fiber construction
- IP65 Protection rating for outdoor applications
- Display size: 500 x 500 x 55mm

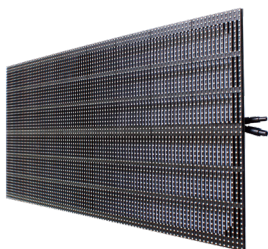

## Leyard CarbonLight CLM Series Mesh LED Video Wall

The Leyard® CarbonLight™ CLM Series is a line of see-through mesh LED video wall displays designed for rental, staging and flexible-fixed applications in indoor and outdoor environments. The Leyard CarbonLight CLM Series is lightweight with high transparency and low wind resistance.

### FEATURES

- Available in 6.9, 10.4 and 15.6mm pixel pitches
- See-through mesh design
- Lightweight carbon fiber construction
- IP65 Protection rating for outdoor applications
- Display size: 1000 x 500 x 45mm

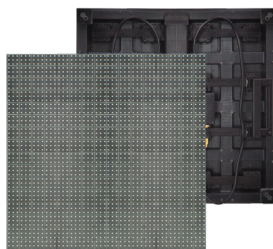

## Leyard CarbonLight CLF Series LED Flooring System

The Leyard® CarbonLight™ CLF Series is an LED flooring system with a lightweight, carbon fiber frame designed to create a high-strength structure built to withstand loads up to 500kg per display. This highly durable LED flooring system is layered with a high-strength, wear-proof mask to increase the lifespan of the displays.

### FEATURES

- Available in 5.2, 6.2 and 10.4mm pixel pitches
- IP65 Protection rating for outdoor applications (for 6.2 and 10.4mm pixel pitches)
- Loads up to 500kg per display
- High-strength, wear-proof mask
- Display size: 500 x 500 x 82mm



# Signature Design with Carbon Fiber Structure

Through thoughtful engineering and craftsmanship, Leyard CarbonLight LED displays feature a thin, lightweight, high-strength carbon fiber cabinet in a modular design. With this unique structural design, Leyard has pioneered, patented and perfected the use of carbon fiber in the construction of LED video wall displays.

## Fast, Flexible Installation & Service

From start to finish, Leyard CarbonLight displays accommodate the fast-paced nature of rental, staging and flexible-fixed environments. With modular designs, free-standing or hanging applications can be quickly constructed using Leyard CarbonLight easy-to-use bracketry. Bracketry systems are designed to accommodate fast servicing, including removing and installing individual displays at any location without disrupting the overall layout.

## Advanced Hardware & Common Components

Leyard CarbonLight displays incorporate common components with fine-tuned, advanced hardware to deliver fast installation, servicing and disassembly. This innovative design makes interacting with power, video and installation components of Leyard CarbonLight displays fast, easy and inexpensive.

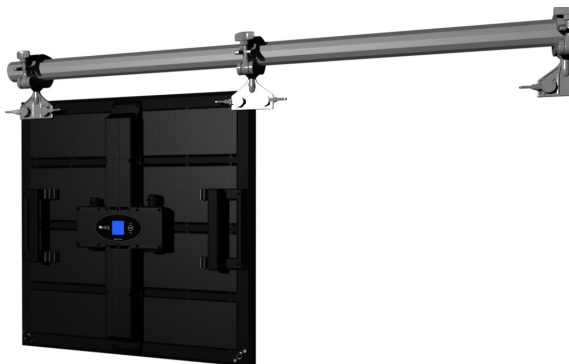

## DESIGNS TO EXCEED EXPECTATIONS

Rental, staging and flexible-fixed installations require a greater level of display flexibility and set-up ease, which is not commonly found in traditional LED video wall displays. With all five Leyard CarbonLight LED product lines, flexibility is at the forefront of product design to accommodate the fast-paced nature of rental and staging environments and creative flexibility required for flexible-fixed installations while delivering stunning visual performance to amaze any audience.

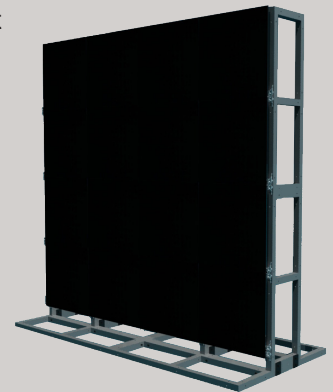

### Leyard CarbonLight features:

- **Light, Thin, Strong Design** — Ideal for environments with limited structural capacity
- **Convenient to Transport** — Lightweight, thin design reduces weight and size to minimize shipping costs
- **Quick Install and Teardown** — Assemble quickly with easy-to-use hardware designed for fast set-up and teardown
- **Free-Hanging & Rigging-Friendly** — Easily hang products with no supporting structure
- **Convenient to Move** — Easily and quickly set-up and reconfigure a design or move the display to another location
- **Eye-Catching Designs** — Swiftly construct video walls with smooth curves, arcs and 90° internal or external corners
- **Easy Access for Swift Service** — Simplified servicing with unique modular display design and easy-to-use bracketry

# LEYARD CARBONLIGHT LED DISPLAYS

Series	CLI Series				CLA Series		CLO Series			CLM Series			CLF Series			
Model Name	CLI1.9	CLI2.6	CLI3.9	CLI5.2	CLA1.5	CLA1.9	CLO3.9	CLO5.2	CLO7.8	CLM6.9	CLM10.4	CLM15.6	CLF5.2	CLF6.2	CLF10.4	
Pixel Pitch (mm)	1.9	2.6	3.9	5.2	1.5	1.9	3.9	5.2	7.8	6.9	10.4	15.6	5.2	6.2	10.4	
Resolution	256x256	192x192	128x128	96x96	160x160	128x128	128x128	96x96	64x64	144x72	96x48	64x32	96x96	80x80	48x48	
Cabinet Size (WxHxD)	500x500x53mm 19.69x19.69x2.09in				250x250x58mm 9.84x9.84x2.28in		500x500x56mm 19.69x19.69x2.20in			1000x500x45mm 39.37x19.69x1.77in			500x500x82mm 19.69x19.69x3.23in			
Cabinet Weight	4.1kg 9.04lb	3.8kg* 8.4lb*	3.9kg* 8.6lb*	3.9kg* 8.6lb*	2.1kg* 4.6lb*	2.0kg* 4.4lb*	5.0kg 11.0lb			4.8kg 10.6lb			8.0kg 17.6lb			
Weight Bearing Capacity (per cabinet)	1000kg** 2204lb**				300kg** 660lb**		1000kg** 2204lb**			1000kg** 2204lb**			500kg 1102lb			
Power Supply	Dual	Single/ Dual	Single/ Dual	Single/ Dual	Single/Dual		Dual			Dual			Dual			
Power Consumption, Maximum (watts)	300/Cabinet 1200/sq m 111/sq ft	150/Cabinet 600/sq m 56/sq ft			75/Cabinet 1200/sq m 111/sq ft		300/Cabinet 1200/sq m 111/sq ft			300/Cabinet 600/sq m 56/sq ft			300/Cabinet 1200/sq m 111/sq ft			
Power Consumption, Typical (watts)	150/Cabinet 600/sq m 56/sq ft	75/Cabinet 300/sq m 28/sq ft			36/Cabinet 576/sq m 54/sq ft		150/Cabinet 600/sq m 56/sq ft			150/Cabinet 300/sq m 28/sq ft			150/Cabinet 600/sq m 56/sq ft			
Line Voltage	100-240V AC, 50/60 Hz				100-240V AC, 50/60 Hz		100-240V AC, 50/60 Hz			100-240V AC, 50/60 Hz			100-240V AC, 50/60 Hz			
Brightness Max (cd/sq. m)	1000	600	1000	1000	700	1000	6000	6000	6000	5000	5000	5000	1500	5000	5000	
Contrast Ratio	4,000:1				4000:1		4000:1			2000:1			2000:1			
LED Refresh Rate (Hz)	3840				3600	3600	3000	3000	1920	3000	4000	3000	1000	1000	1000	
Color Temperature, Calibrated	6500k				6500k		6500k			6500k			6500k			
Viewing Angle, Horizontal	140°				140°		140°			140°			140°			
Viewing Angle, Vertical	140°				140°		140°			140°			140°			
Video Input Type (to VSP)	DVI, HDMI, HD-SDI				DVI, HDMI, HD-SDI		DVI, HDMI, HD-SDI			DVI, HDMI, HD-SDI			DVI, HDMI, HD-SDI			
Frame Rate	30~70Hz				30~70Hz		30~70Hz			30~70Hz			30~70Hz			
Control Input Type	CAT6 Ethernet				CAT6 Ethernet		CAT6 Ethernet			CAT6 Ethernet			CAT6 Ethernet			
Grey Scale	14 bit				16 bit		14 bit			14 bit			14 bit			
Service Access	Front	Front/ Rear	Front/ Rear	Front/ Rear	Rear		Rear			Rear			Rear			
Installation	Hanging, Standing				Hanging, Standing		Hanging, Standing			Hanging, Standing			Floor			
Lifetime, Typical	75000 hrs				75000 hrs		75000 hrs			75000 hrs			75000 hrs			
Environment	Indoor				Indoor		Outdoor			Indoor or Outdoor			Indoor or Outdoor			
Protection Rating	IP40				IP40		IP65	IP65	IP65	IP65	IP65	IP65	IP65	IP40	IP65	IP65
Operating Temperature (degrees F/C)	-20° to 40° C -4° to 104° F				-20° to 40° C -4° to 104° F		-20° to 40° C -4° to 104° F			-20° to 40° C -4° to 104° F			-20° to 40° C -4° to 104° F			
Storage Temperature (degrees F/C)	-35° to 60° C -31° to 140° F				-20° to 50° C -4° to 122° F		-20° to 50° C -4° to 122° F			-20° to 50° C -4° to 122° F			-20° to 50° C -4° to 122° F			
Cabinet Material	Carbon Fiber				Carbon Fiber		Carbon Fiber			Carbon Fiber			Carbon Fiber			

\* Display weight includes single PSU  
 \*\* Weight Bearing Capacity for hanging

[www.leyard.com](http://www.leyard.com) | [www.planar.com](http://www.planar.com)

**North America**  
 1-866-475-2627  
[sales@leyardgroup.com](mailto:sales@leyardgroup.com)

**EMEA**  
 +421-907-775-941  
[sales.emea@leyardgroup.com](mailto:sales.emea@leyardgroup.com)

**APAC**  
 +86-755-29671180  
[info.asia@leyardgroup.com](mailto:info.asia@leyardgroup.com)

**Japan**  
 +81-3-6915-2768  
[info.japan@leyardgroup.com](mailto:info.japan@leyardgroup.com)

**Latin America**  
 +55-41-3059-5100  
[info.brazil@leyardgroup.com](mailto:info.brazil@leyardgroup.com)