

REVISION HISTORY					
ECO	ZONE	REV.	DESCRIPTION	DATE	APPR'D

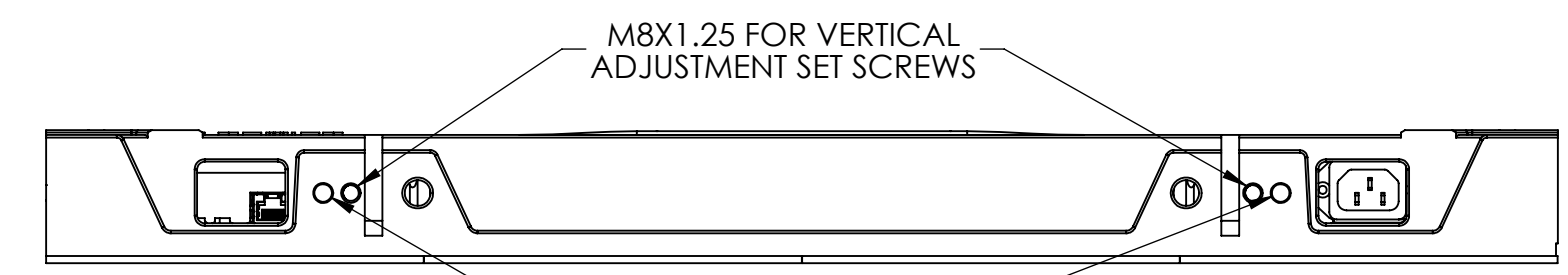
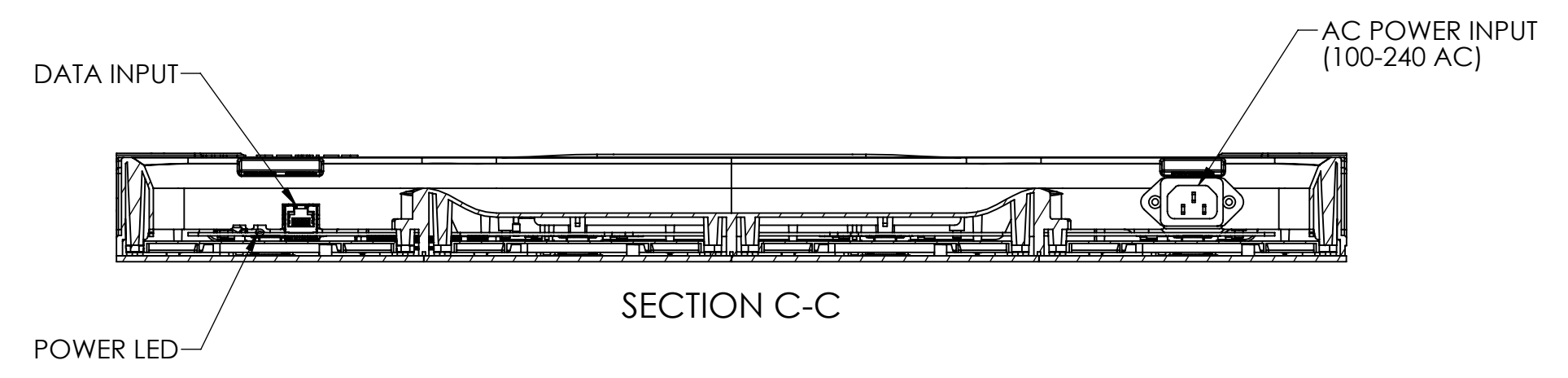
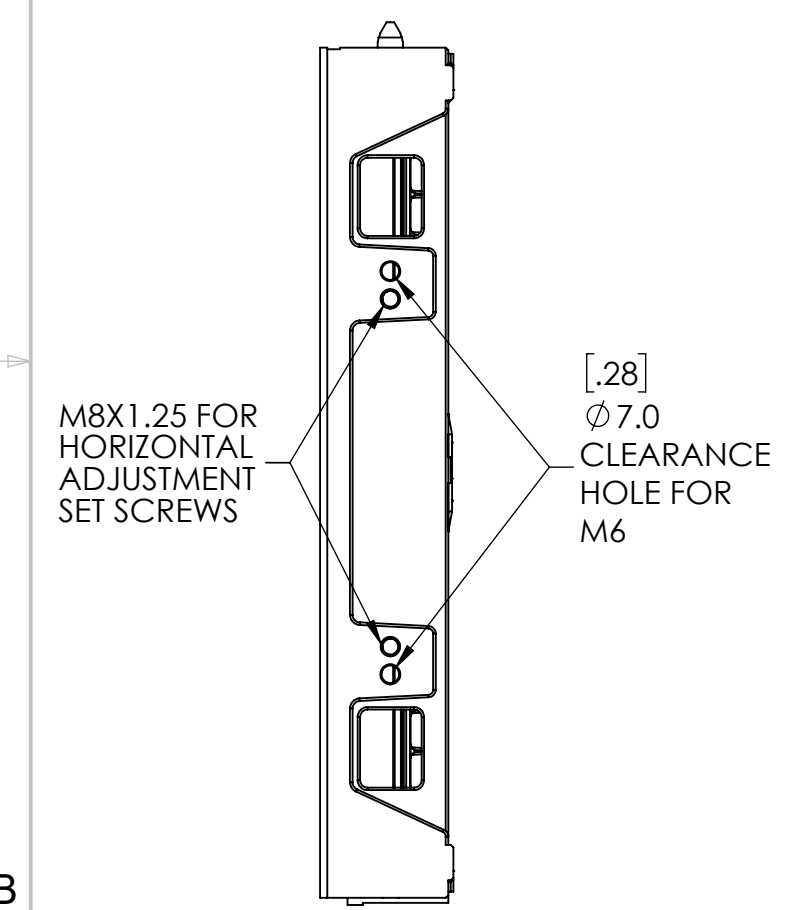
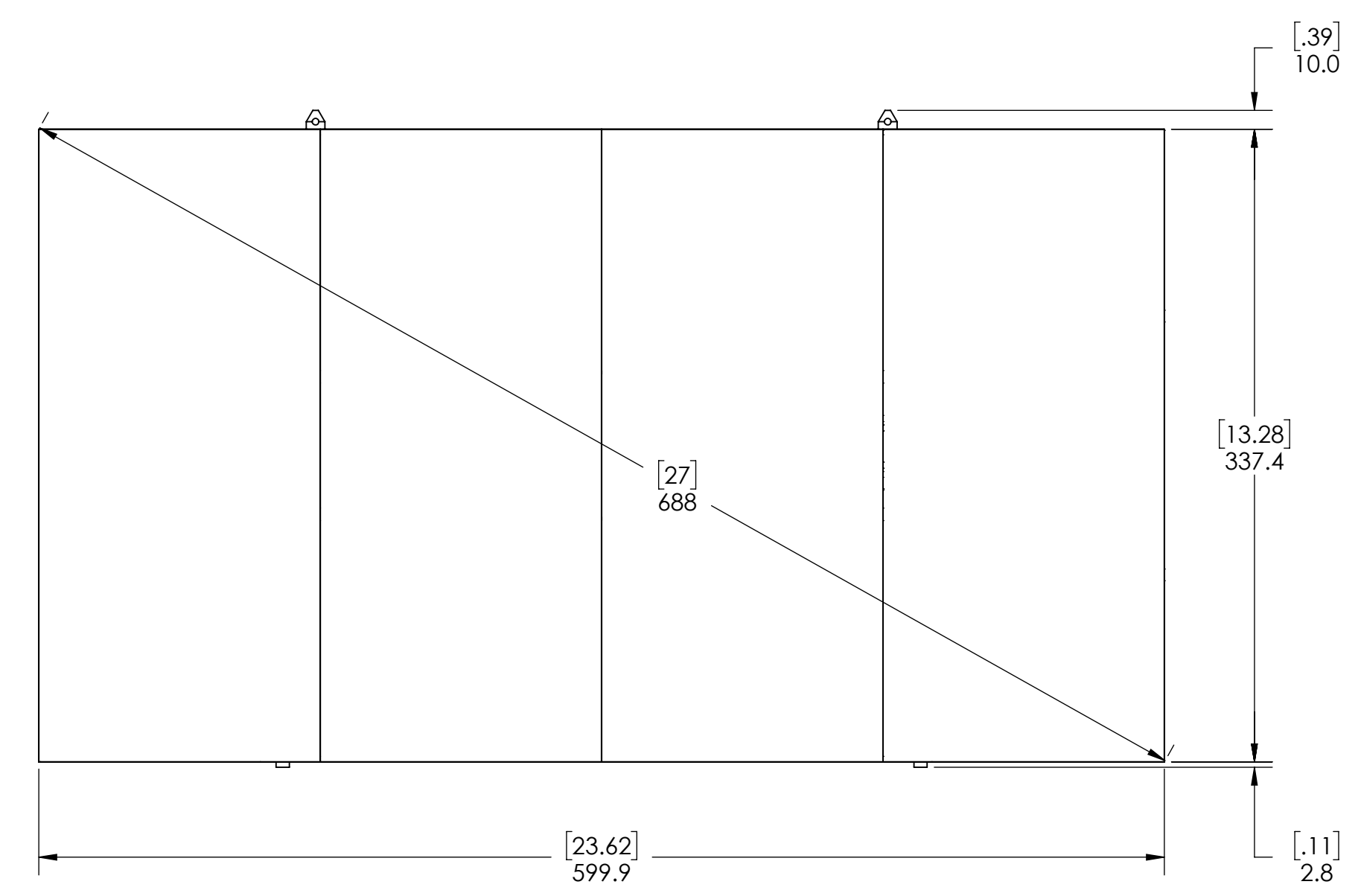
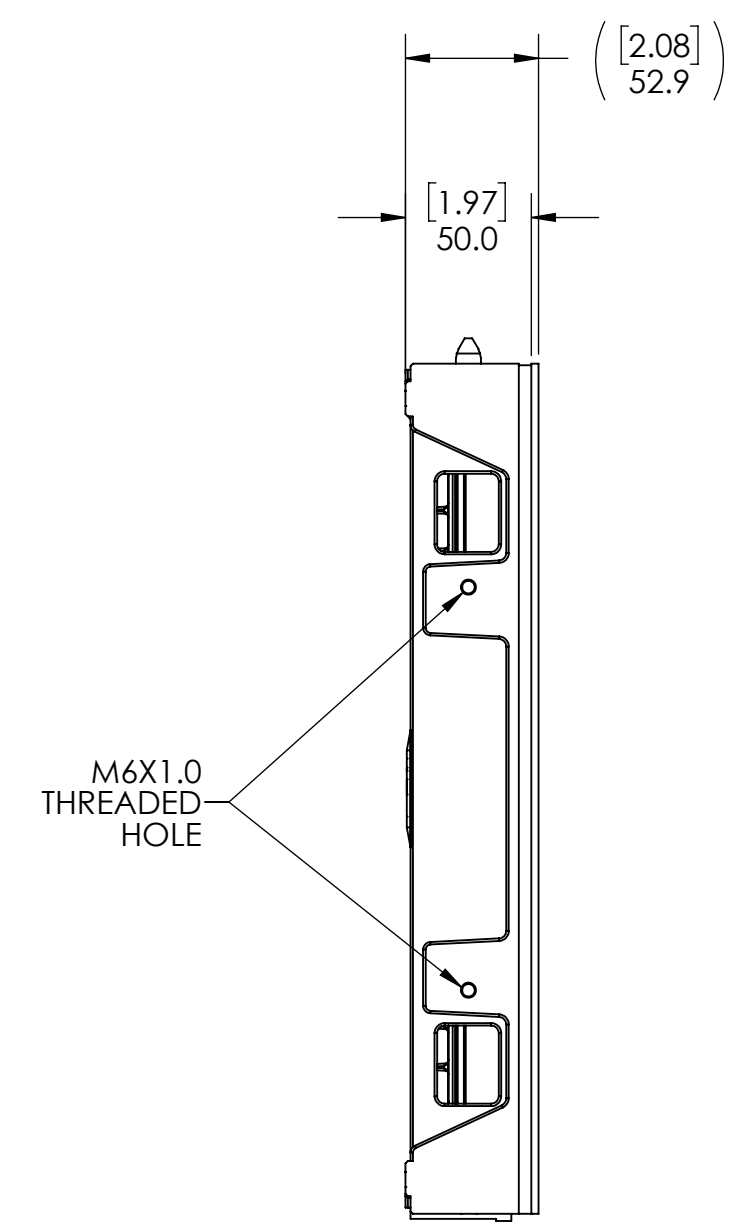
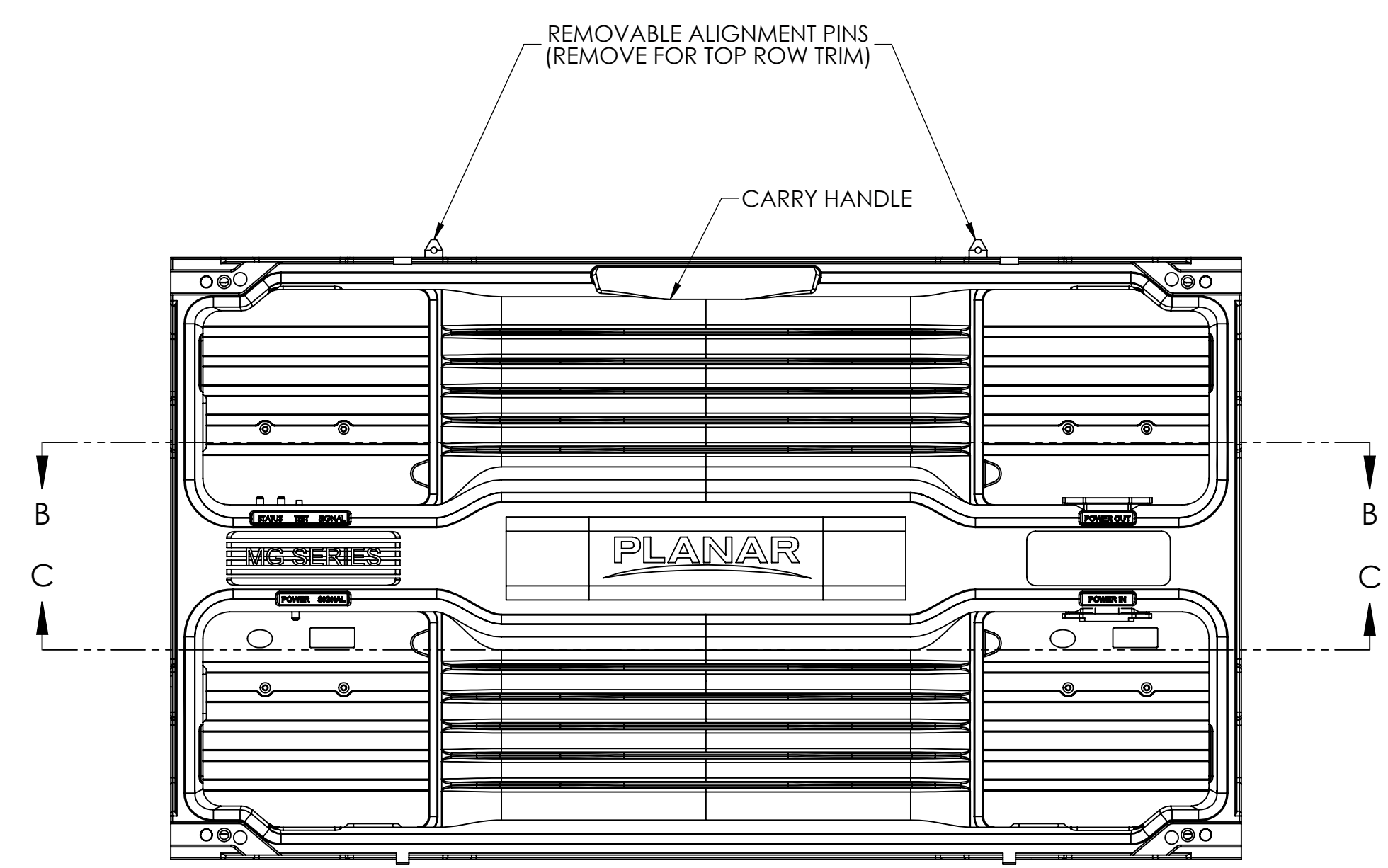
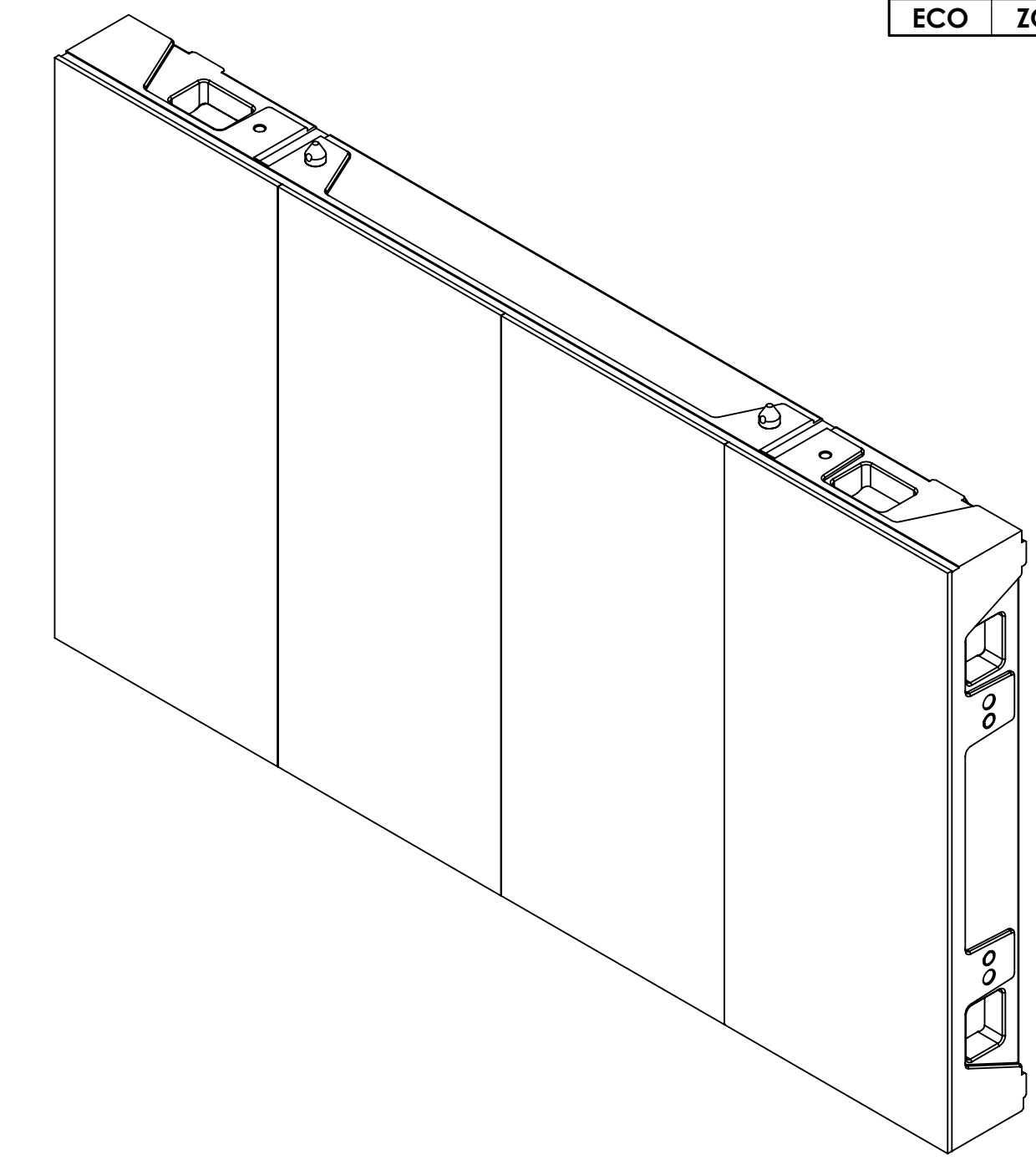
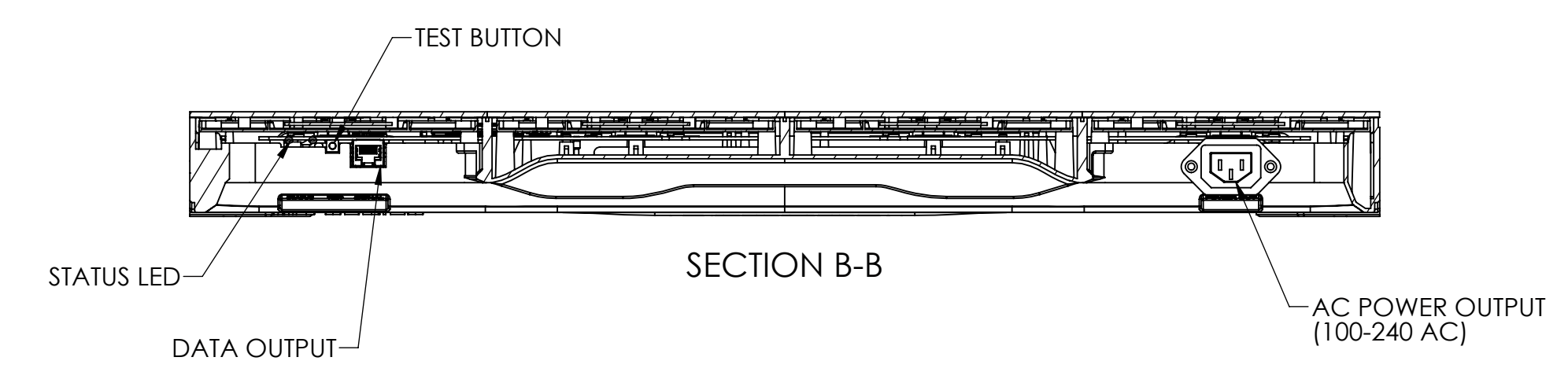
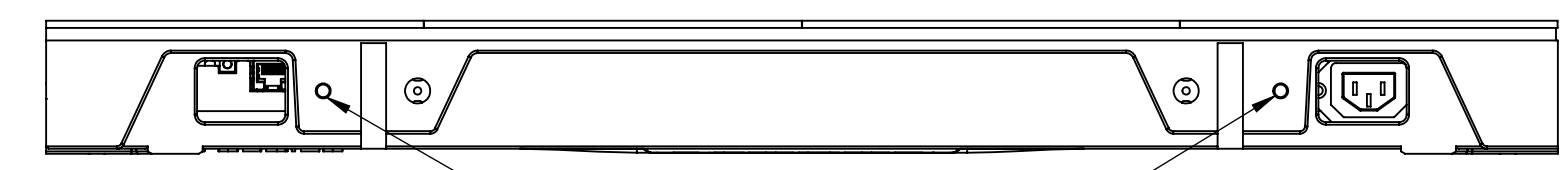

1. SPECIFICATIONS SUBJECT TO CHANGE WITHOUT NOTICE
NOTES: UNLESS OTHERWISE SPECIFIED.

UNLESS OTHERWISE SPECIFIED: DIMENSIONS ARE IN MILLIMETERS (INCHES)		ENGR BY		 PLANAR SYSTEMS, INC. 1195 NE COMPTON DRIVE HILLSBORO, OR 97006 USA
TOLERANCES:		DRAWN BY	JAC	
X= ±1	XX= ±.25	CHECKED BY		TITLE
.X= ±.5	∠= ±1°	USED ON		MGP PRODUCT OUTLINE
DIMENSIONING AND TOLERANCING PER ASME Y14.5M-1994		MATERIAL		SIZE
THIRD ANGLE PROJECTION		FINISH		D
				PART NO
				-
				DRAWING NO
				MGP Outline-
				REV
				A
SCALE	1:3	DO NOT SCALE	SHEET	1 OF 8

THIS DRAWING CONTAINS INFORMATION PROPRIETARY TO PLANAR SYSTEMS, INC. ANY REPRODUCTION IN PART OR WHOLE WITHOUT THE WRITTEN PERMISSION OF PLANAR SYSTEMS IS PROHIBITED. THIS DRAWING IS SUPPLIED FOR INFORMATION, IDENTIFICATION, ENGINEERING EVALUATION, AND/OR INSPECTION PURPOSES ONLY AND MAY NOT BE USED AS BASIS FOR THE MANUFACTURING OF PRODUCTS OR THE FURNISHING OF SERVICES TO PLANAR SYSTEMS OR TO ANY THIRD PARTY UNLESS AUTHORIZED IN WRITING BY PLANAR SYSTEMS.

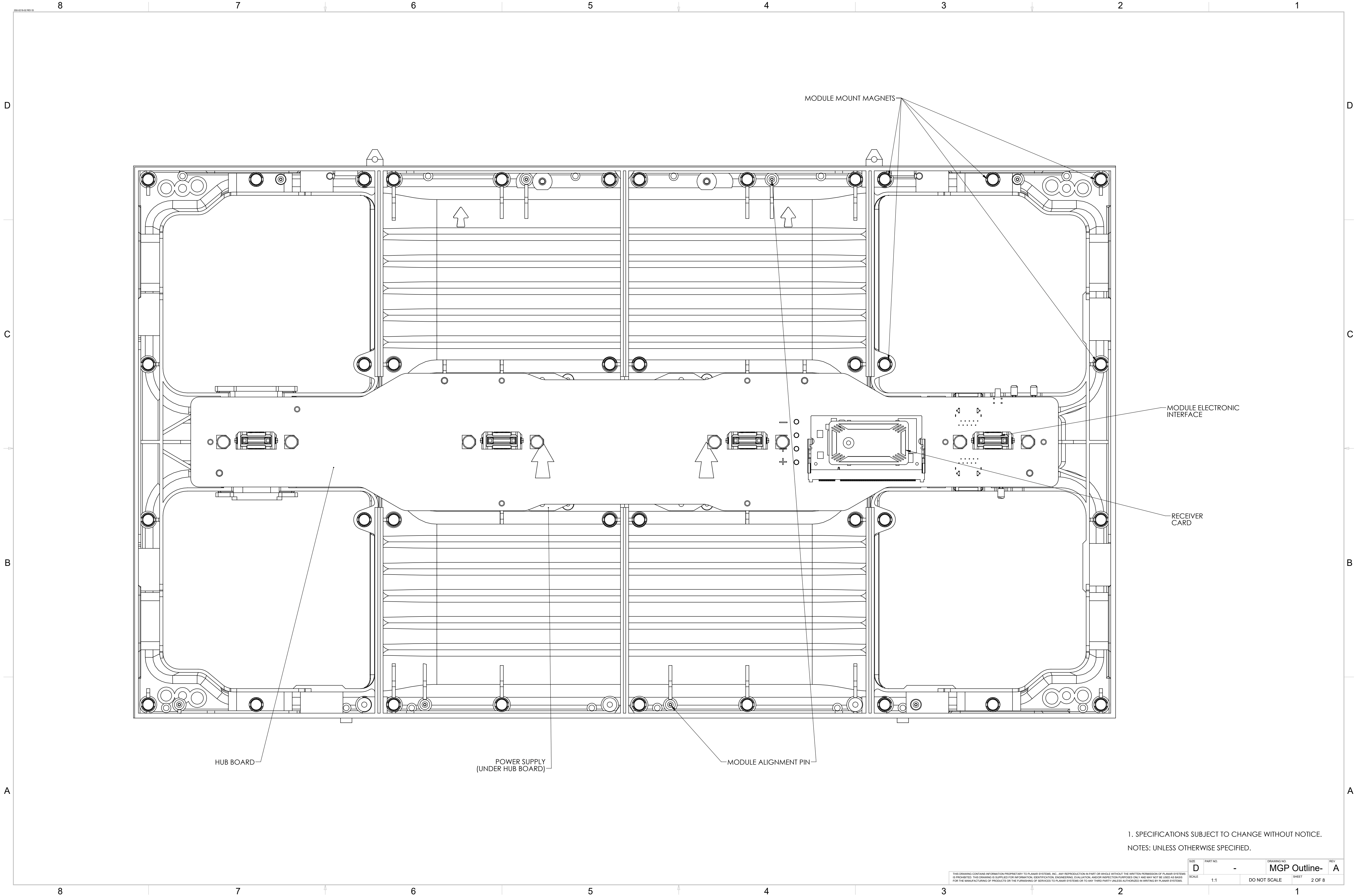

1. SPECIFICATIONS SUBJECT TO CHANGE WITHOUT NOTICE.
 NOTES: UNLESS OTHERWISE SPECIFIED.

SIZE	PART NO.	DRAWING NO.	REV.
D	-	MGP Outline-	A
SCALE	1:1	DO NOT SCALE	SHEET 2 OF 8

THIS DRAWING CONTAINS INFORMATION PROPRIETARY TO PLANAR SYSTEMS, INC. ANY REPRODUCTION IN PART OR WHOLE WITHOUT THE WRITTEN PERMISSION OF PLANAR SYSTEMS IS PROHIBITED. THIS DRAWING IS SUPPLIED FOR INFORMATION, IDENTIFICATION, ENGINEERING EVALUATION, AND/OR INSPECTION PURPOSES ONLY AND MAY NOT BE USED AS BASIS FOR THE MANUFACTURING OF PRODUCTS OR THE FURNISHING OF SERVICES TO PLANAR SYSTEMS OR TO ANY THIRD PARTY UNLESS AUTHORIZED IN WRITING BY PLANAR SYSTEMS.

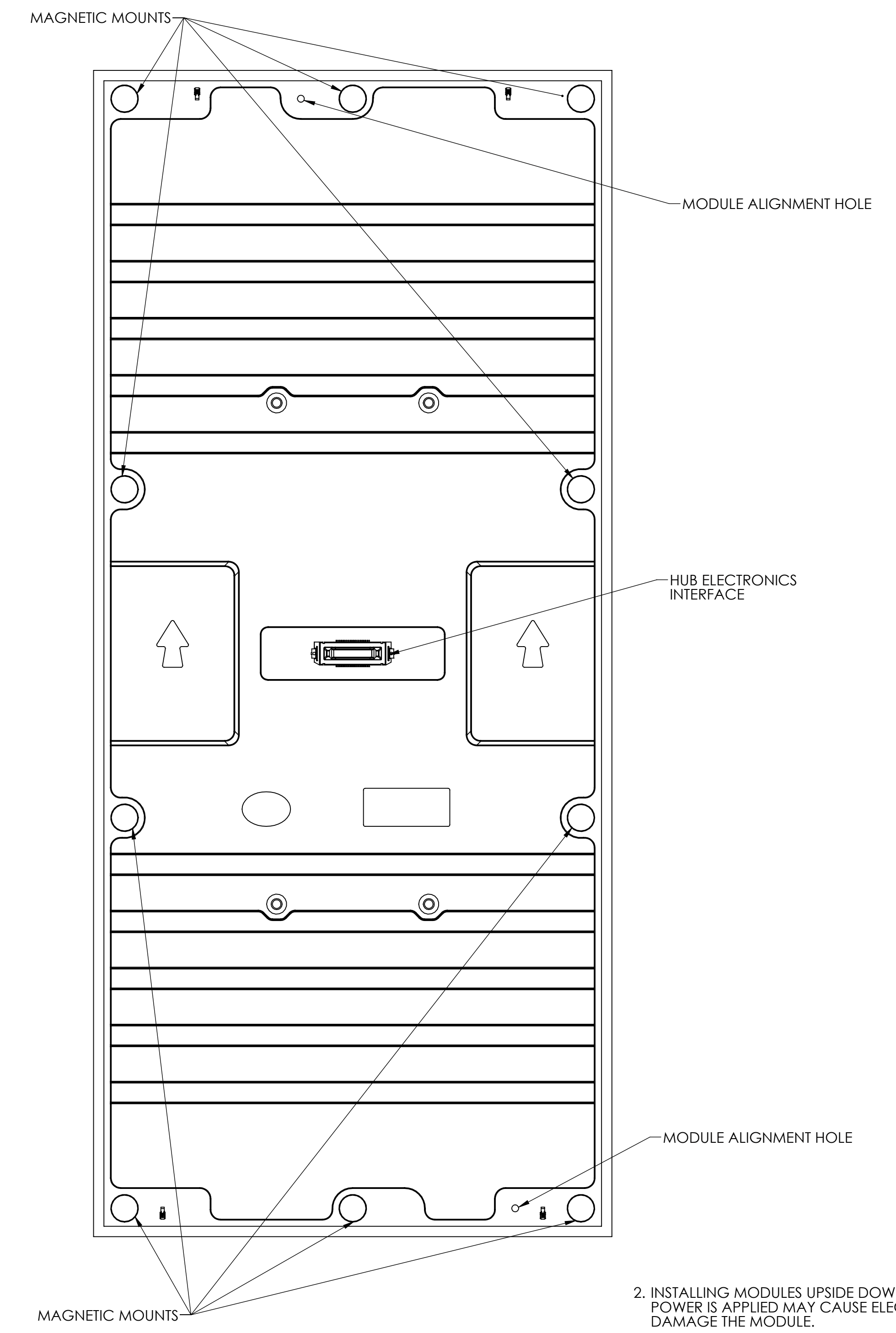
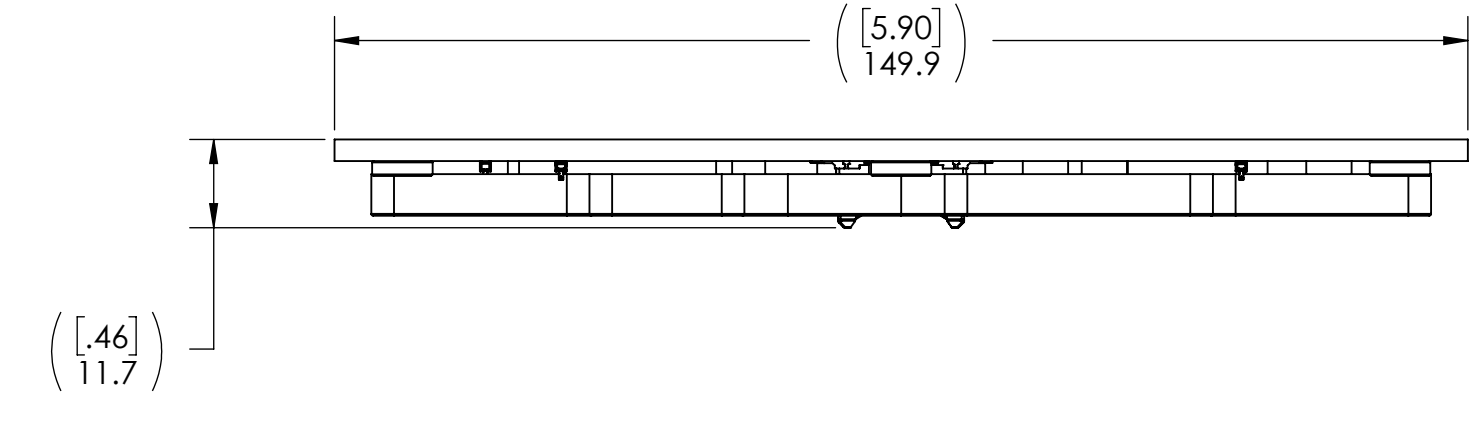
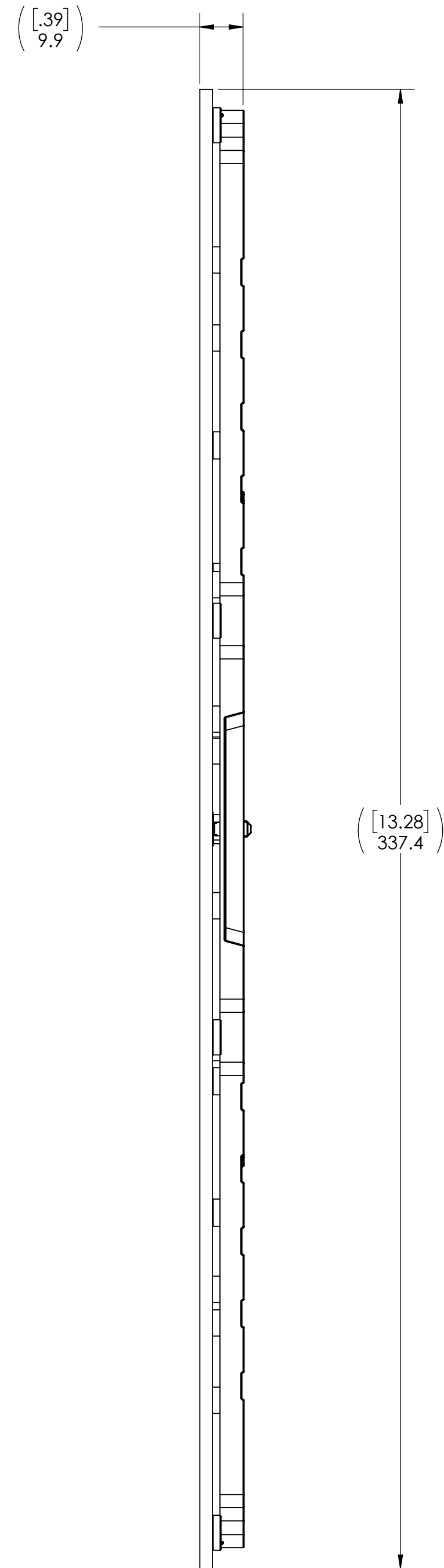
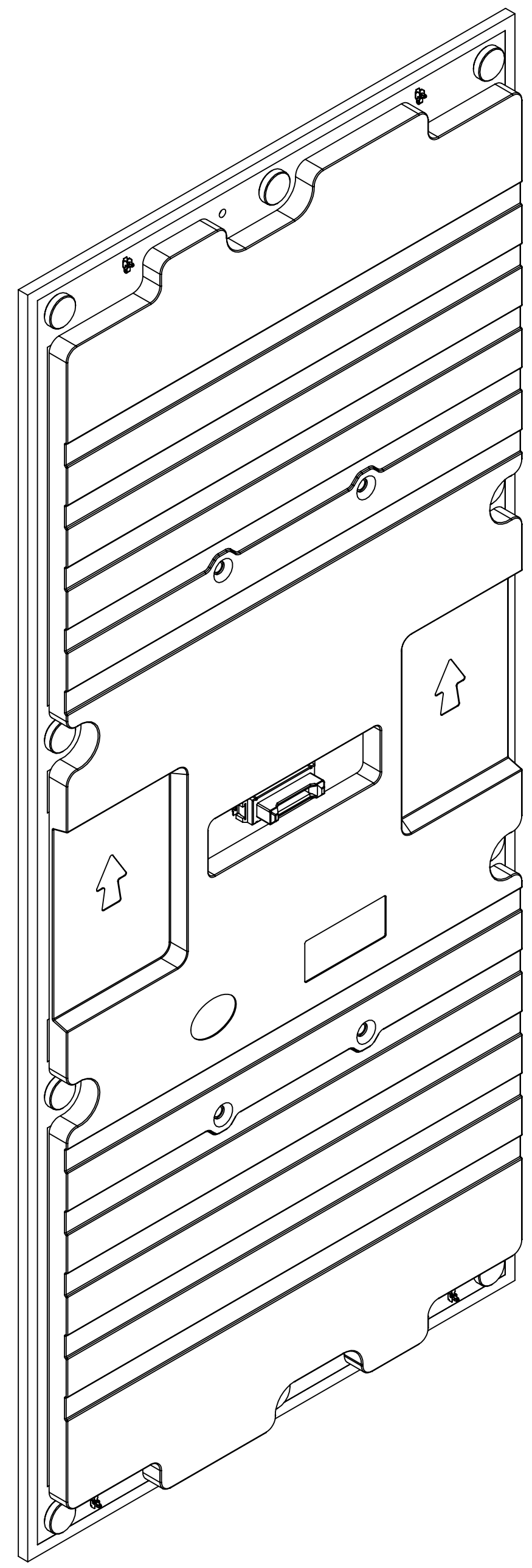

- 2. INSTALLING MODULES UPSIDE DOWN IN A CABINET WHILE POWER IS APPLIED MAY CAUSE ELECTRICAL SHORTS THAT DAMAGE THE MODULE.
- 1. SPECIFICATIONS SUBJECT TO CHANGE WITHOUT NOTICE.
- NOTES: UNLESS OTHERWISE SPECIFIED.

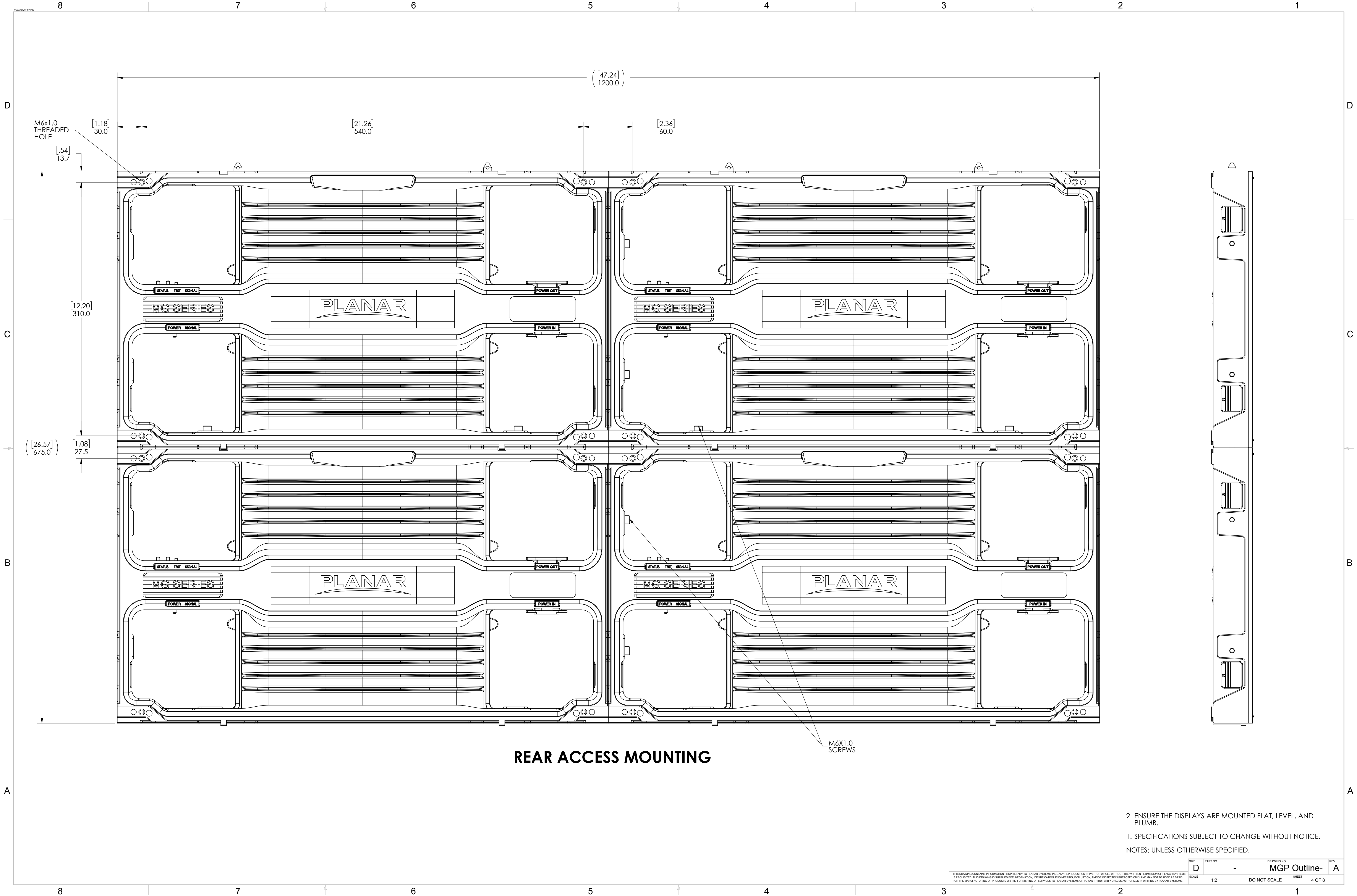

REAR ACCESS MOUNTING

- 2. ENSURE THE DISPLAYS ARE MOUNTED FLAT, LEVEL, AND PLUMB.
 - 1. SPECIFICATIONS SUBJECT TO CHANGE WITHOUT NOTICE.
- NOTES: UNLESS OTHERWISE SPECIFIED.

SIZE	PART NO.	DRAWING NO.	REV.
D	-	MGP Outline-	A
SCALE	1:2	DO NOT SCALE	SHEET 4 OF 8

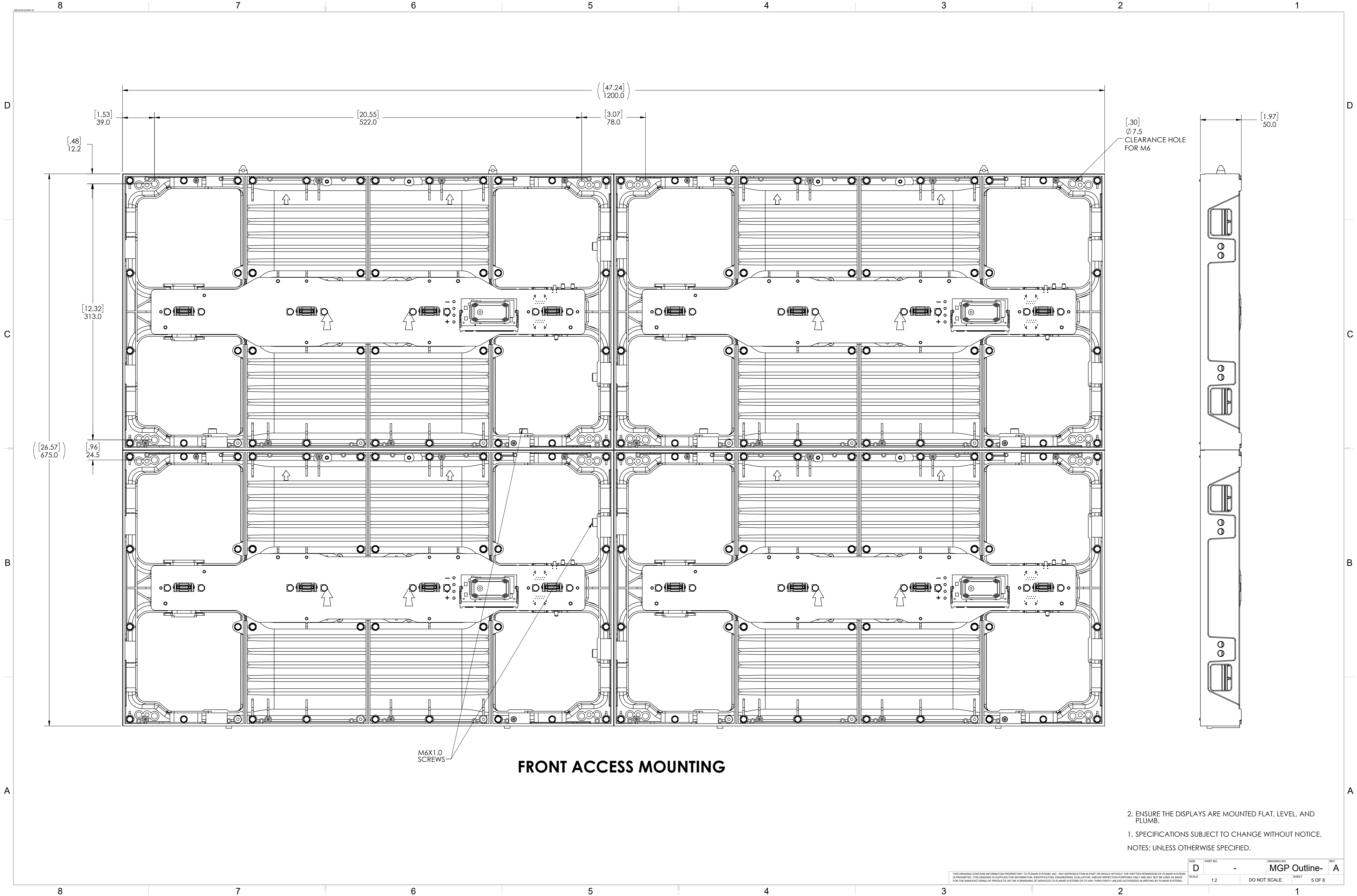

FRONT ACCESS MOUNTING

2. ENSURE THE DISPLAYS ARE MOUNTED FLAT, LEVEL, AND PLUMB.
 1. SPECIFICATIONS SUBJECT TO CHANGE WITHOUT NOTICE.
- NOTES: UNLESS OTHERWISE SPECIFIED.

SIZE	PART NO.	DRAWING NO.	REV.
D	-	MGP Outline-	A
SCALE	1:2	DO NOT SCALE	SHEET 5 OF 8

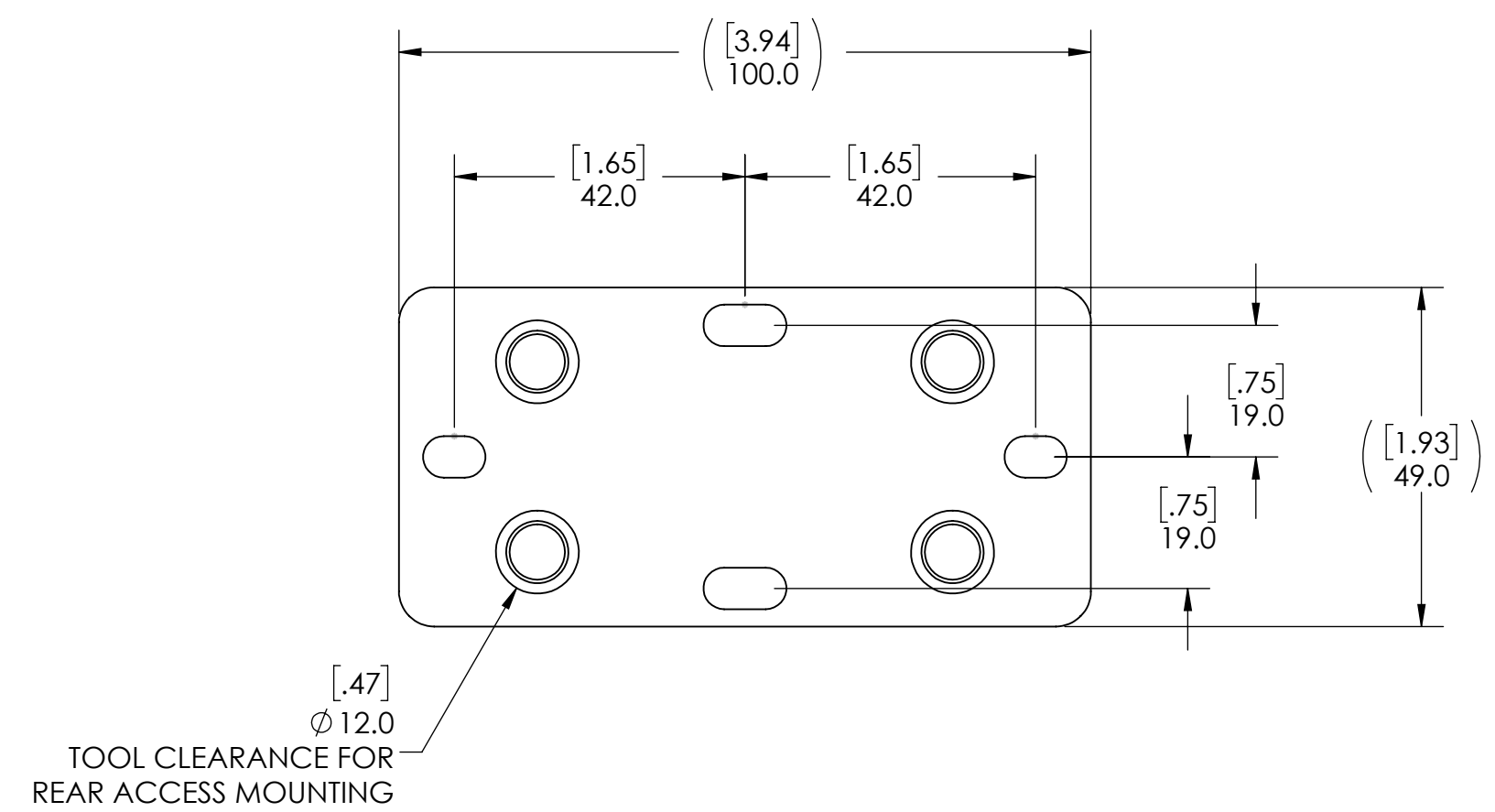
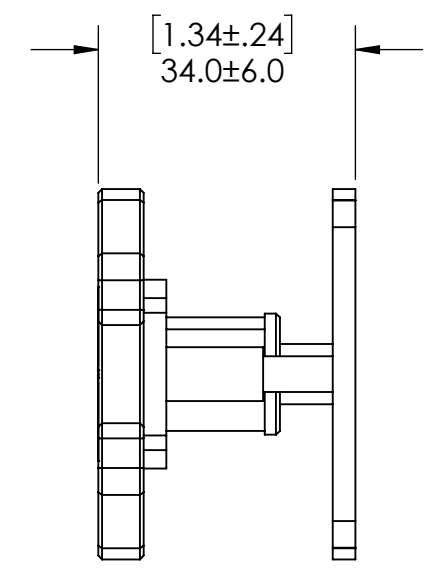
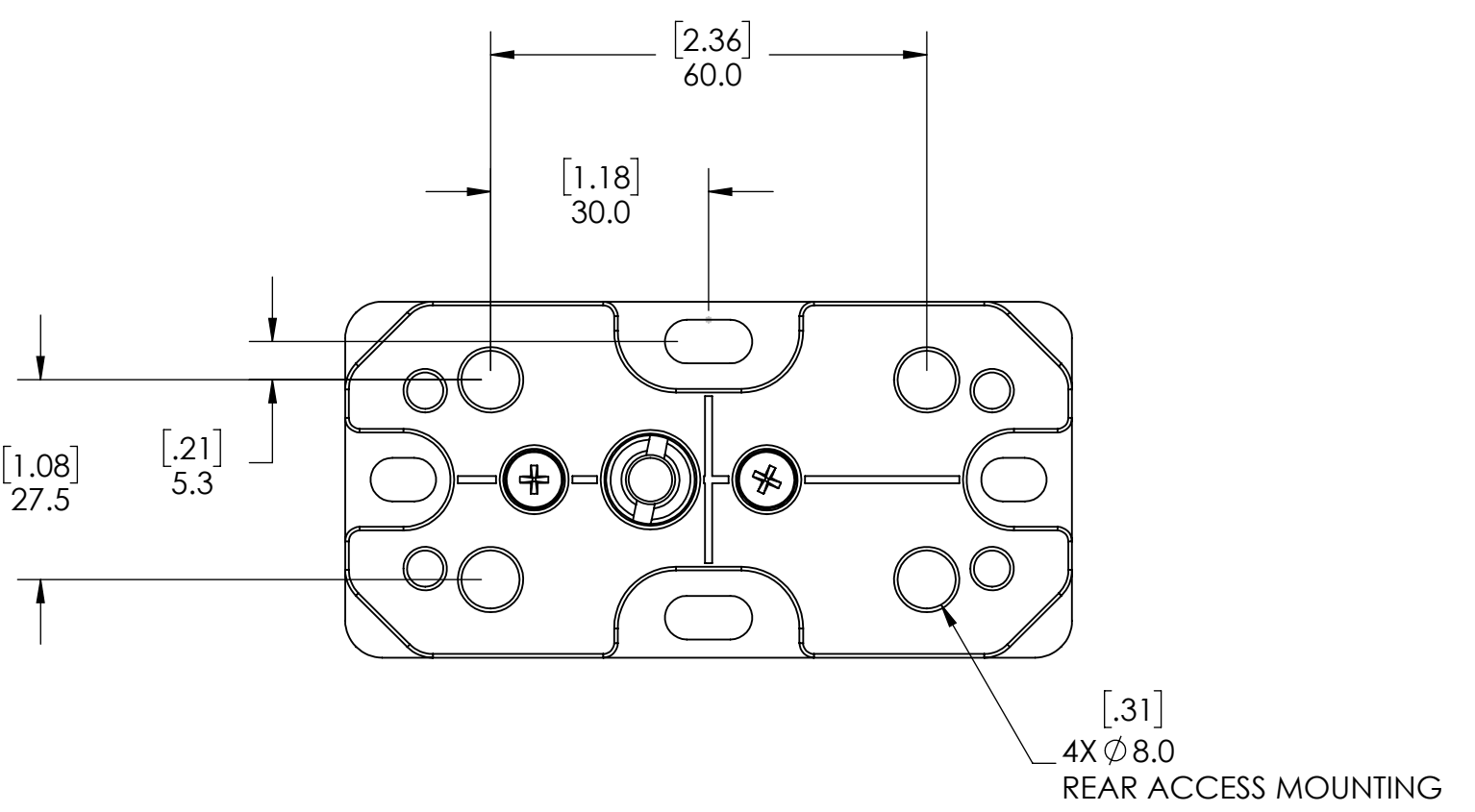
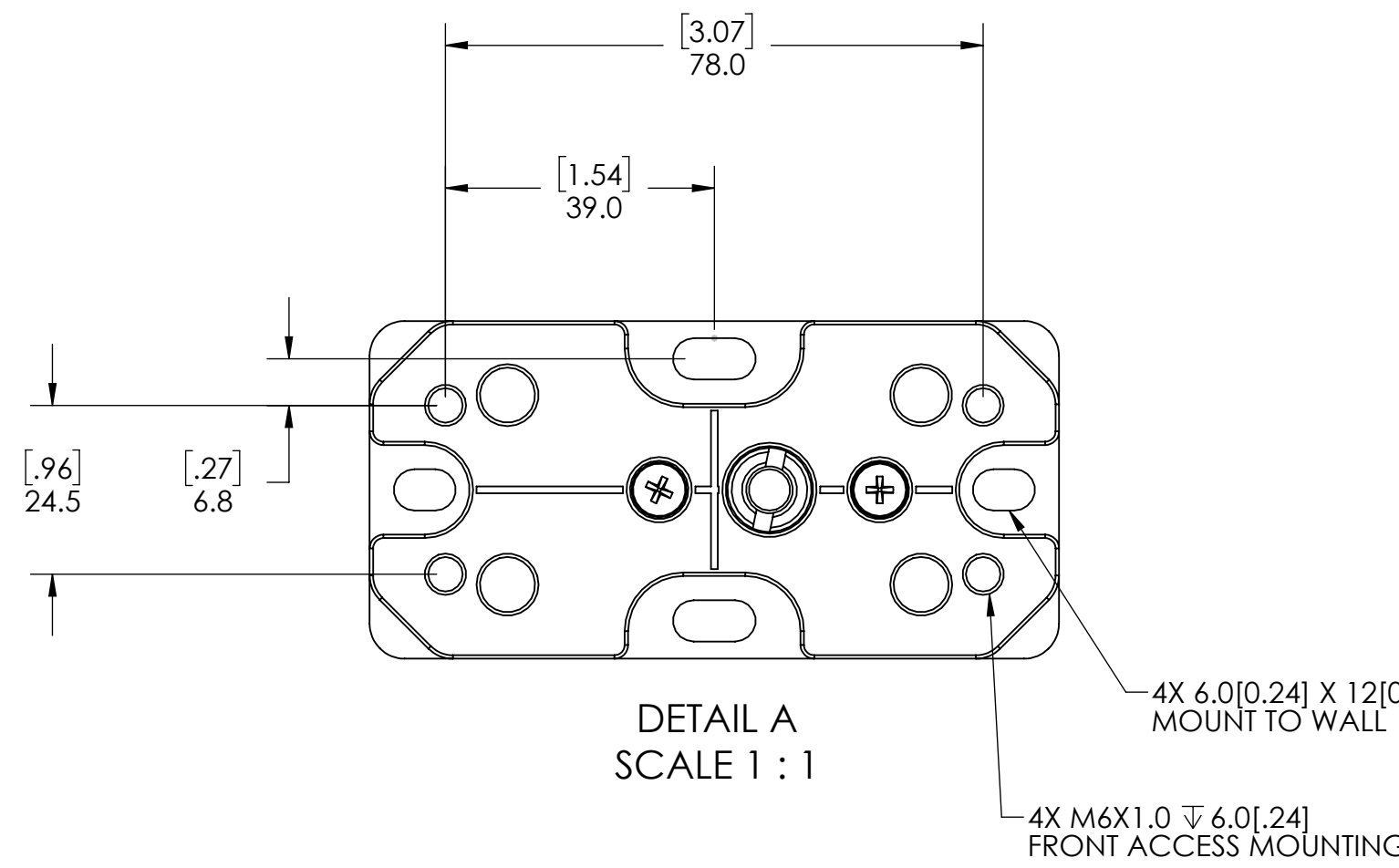
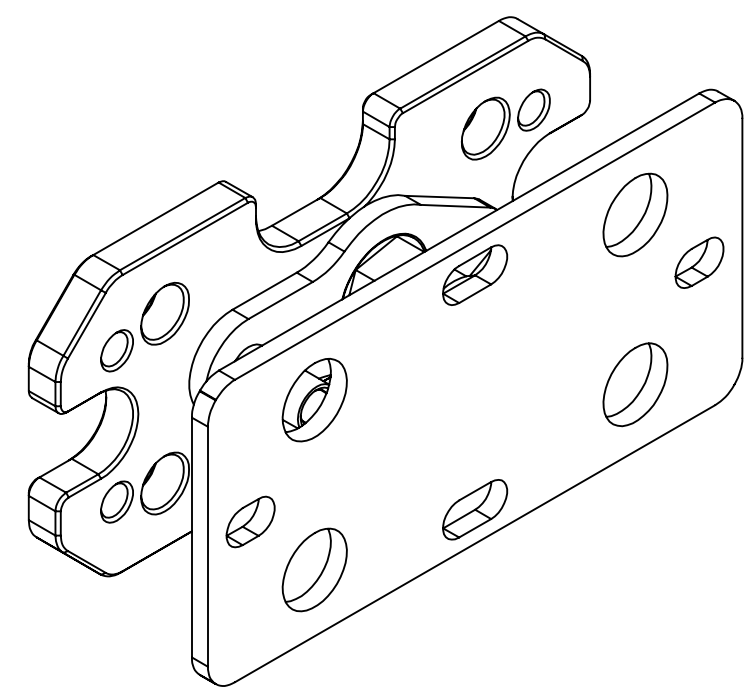
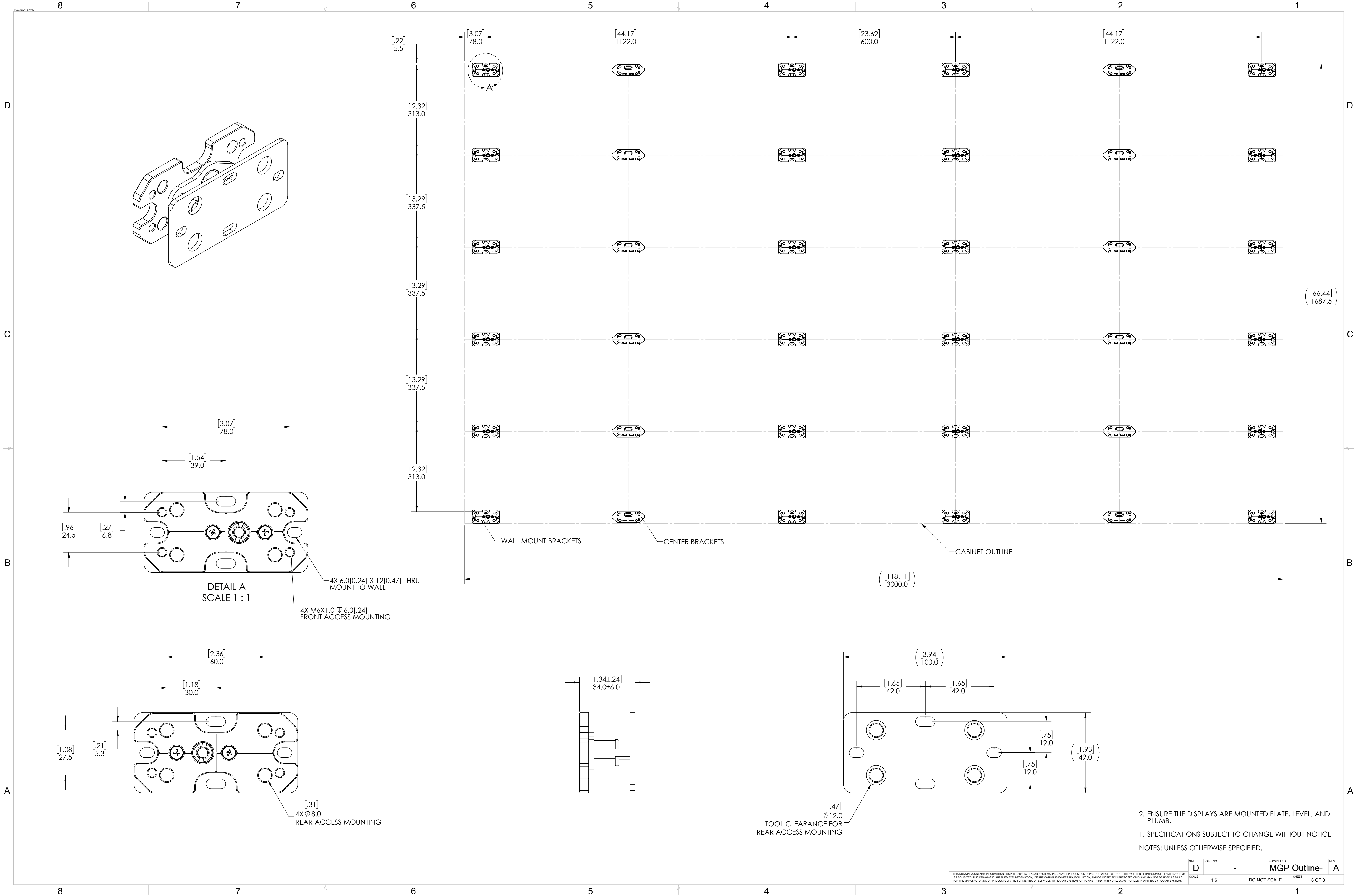

2. ENSURE THE DISPLAYS ARE MOUNTED FLATE, LEVEL, AND PLUMB.
 1. SPECIFICATIONS SUBJECT TO CHANGE WITHOUT NOTICE
- NOTES: UNLESS OTHERWISE SPECIFIED.

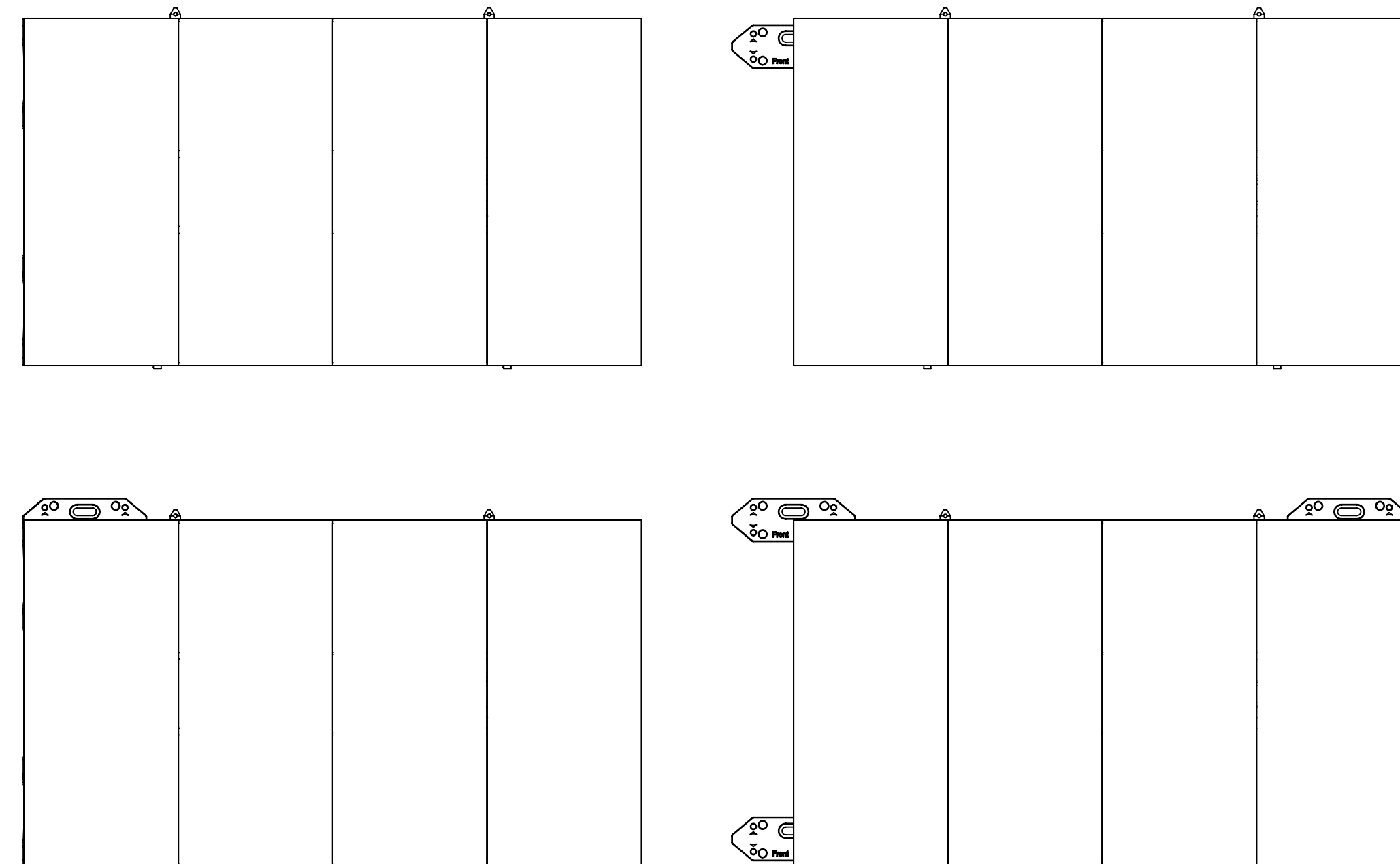
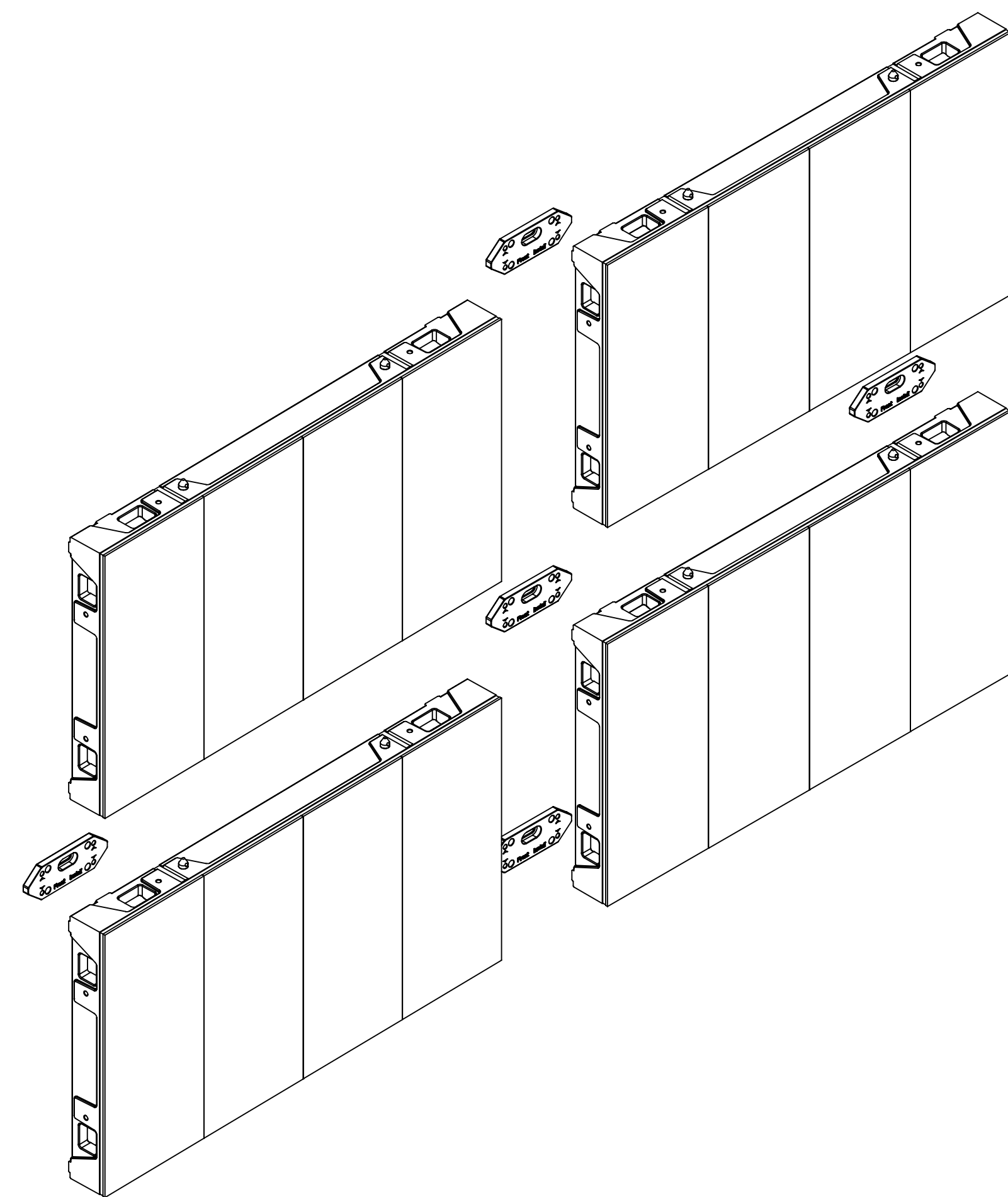

CENTER BRACKET

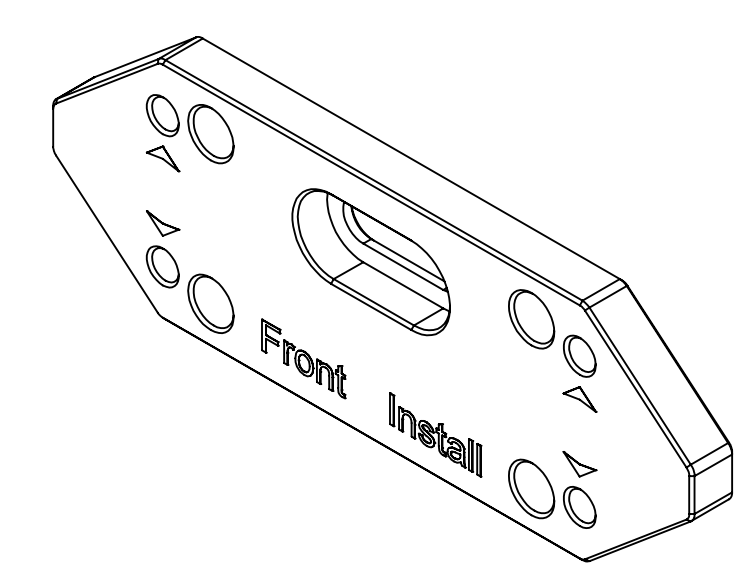
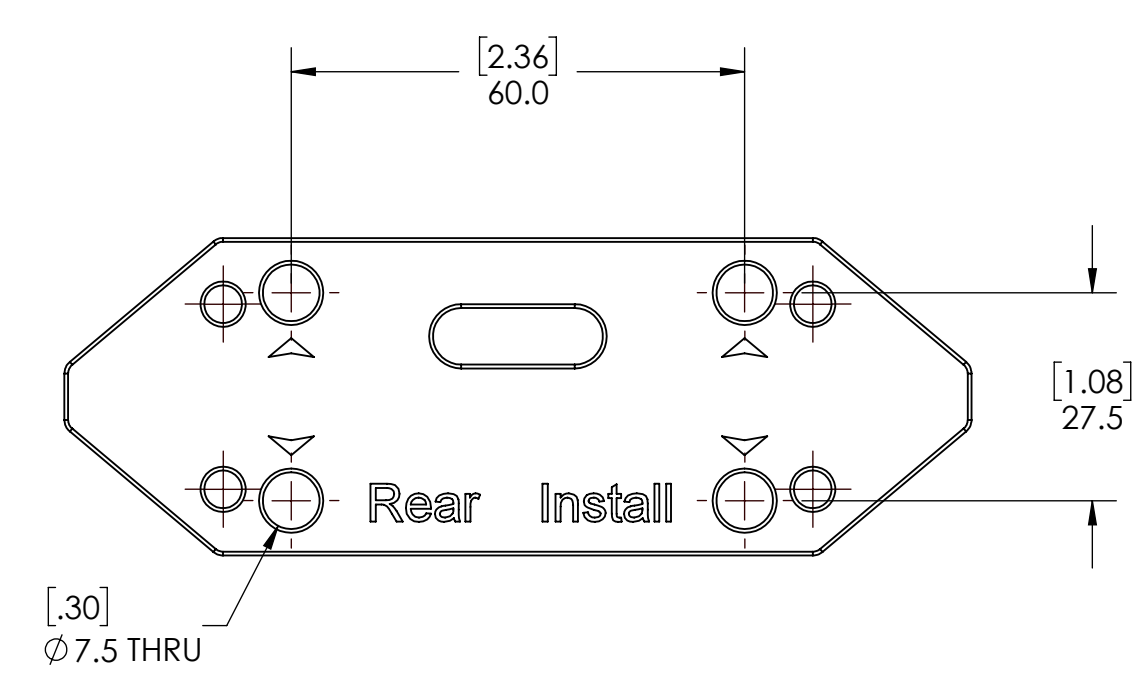
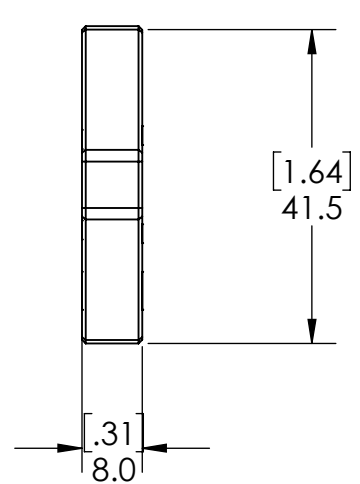
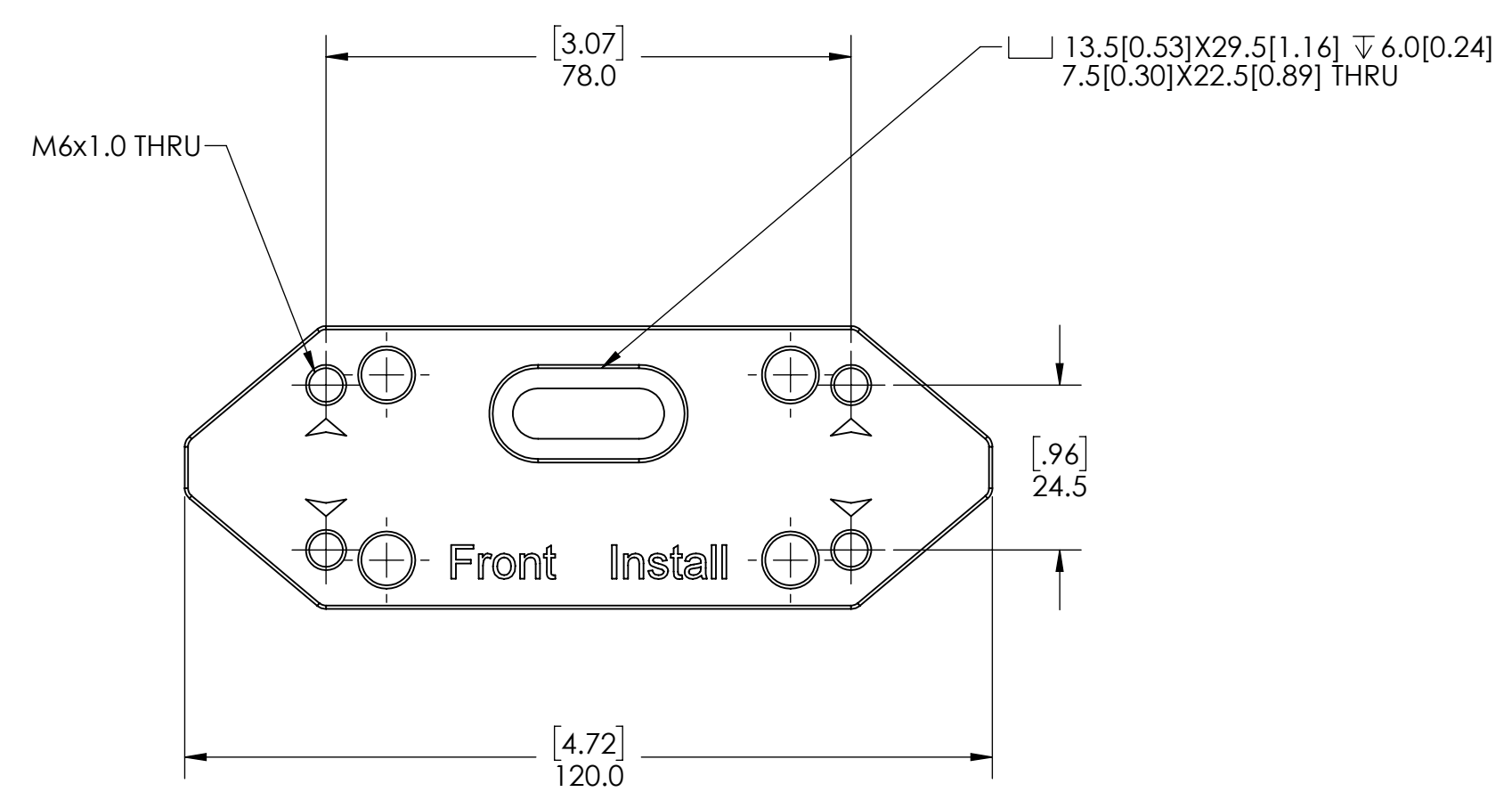

1. SPECIFICATIONS SUBJECT TO CHANGE WITHOUT NOTICE.
 NOTES: UNLESS OTHERWISE SPECIFIED.

SIZE	PART NO.	DRAWING NO.	REV.
D	-	MGP Outline-	A
SCALE	1:5	DO NOT SCALE	SHEET 7 OF 8

TRIM INSTALLATION

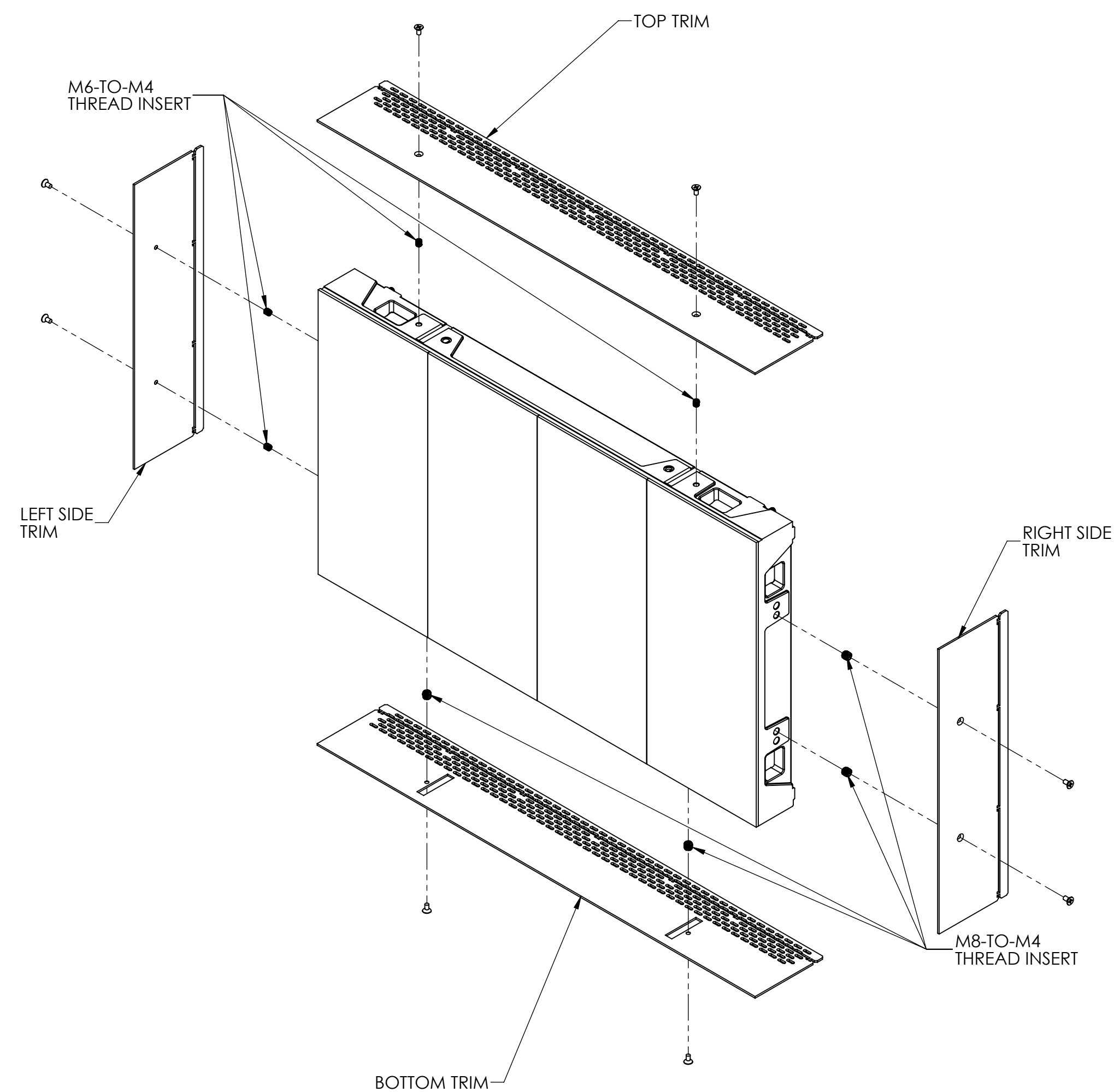

TOP TRIM

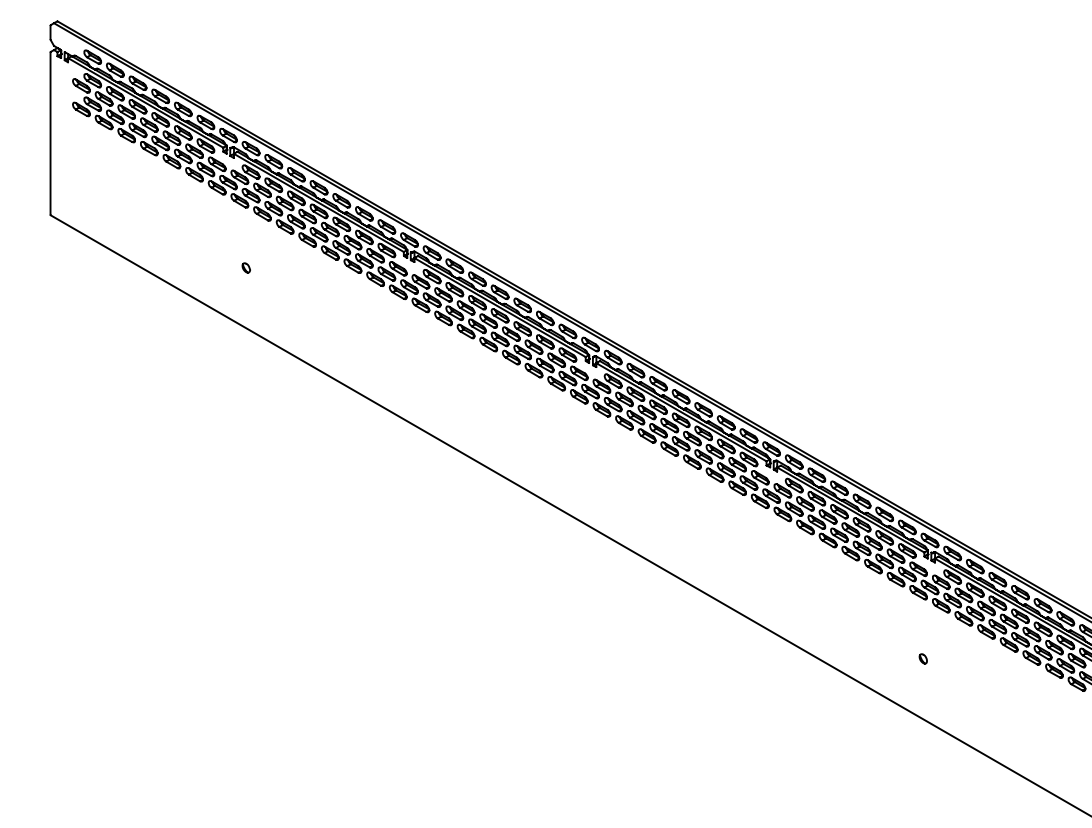
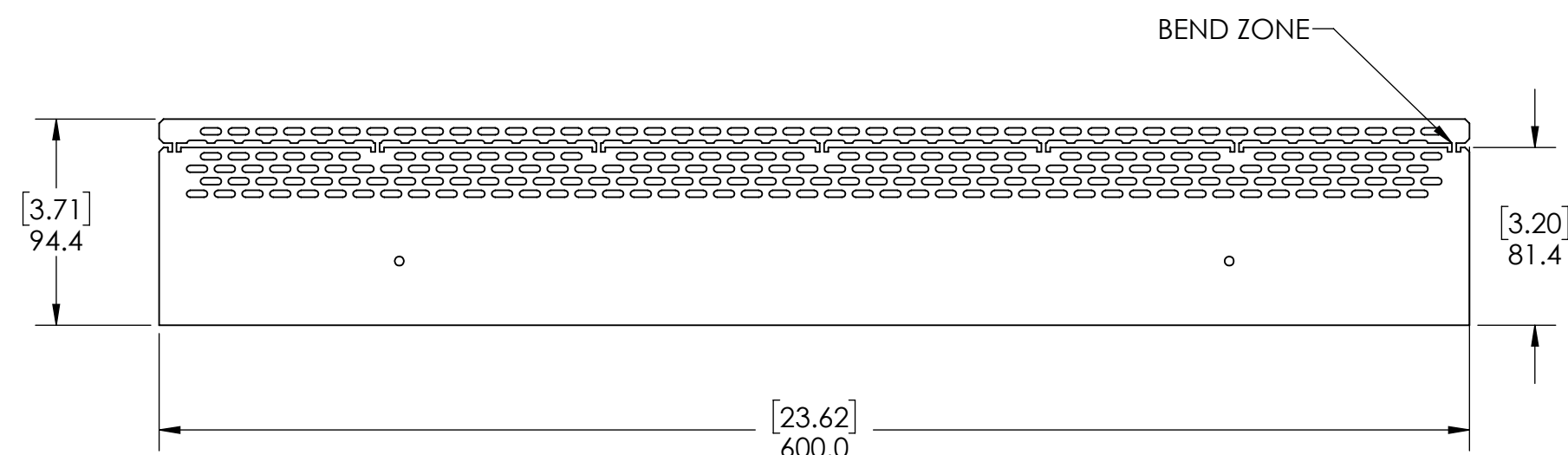

BOTTOM TRIM

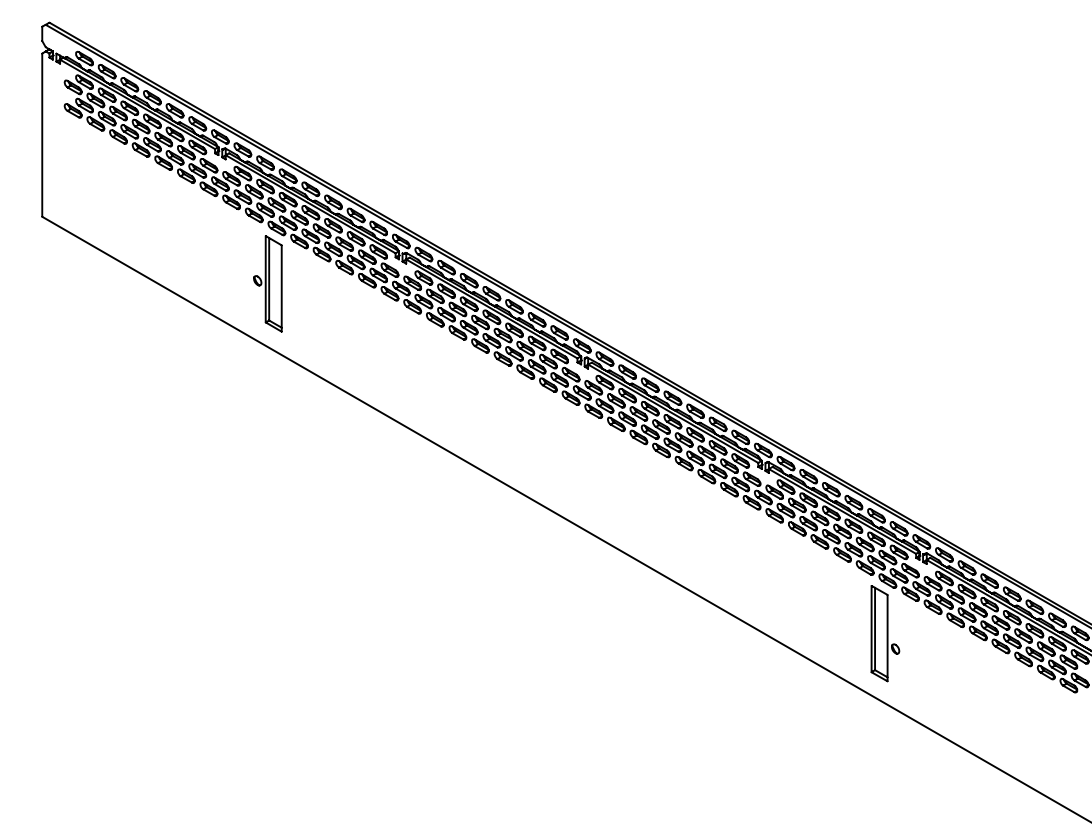
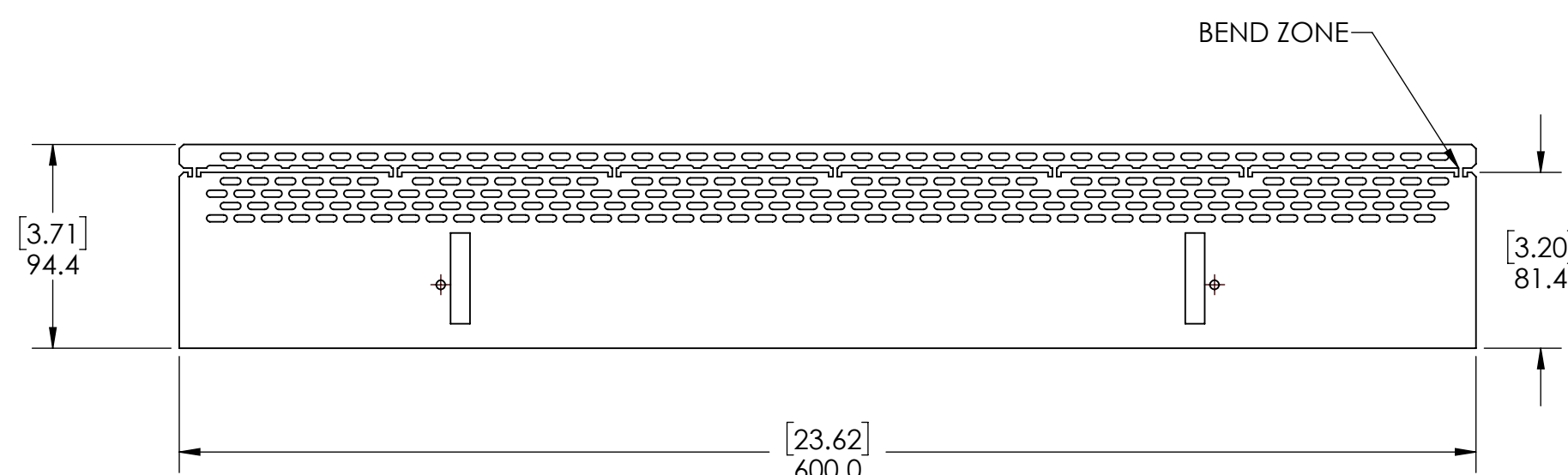

LEFT TRIM

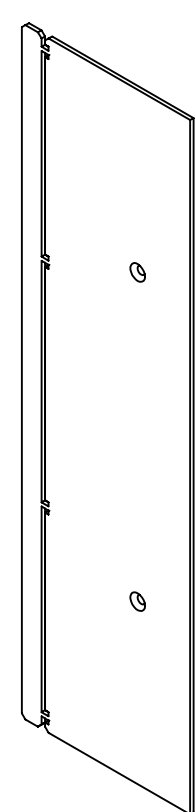
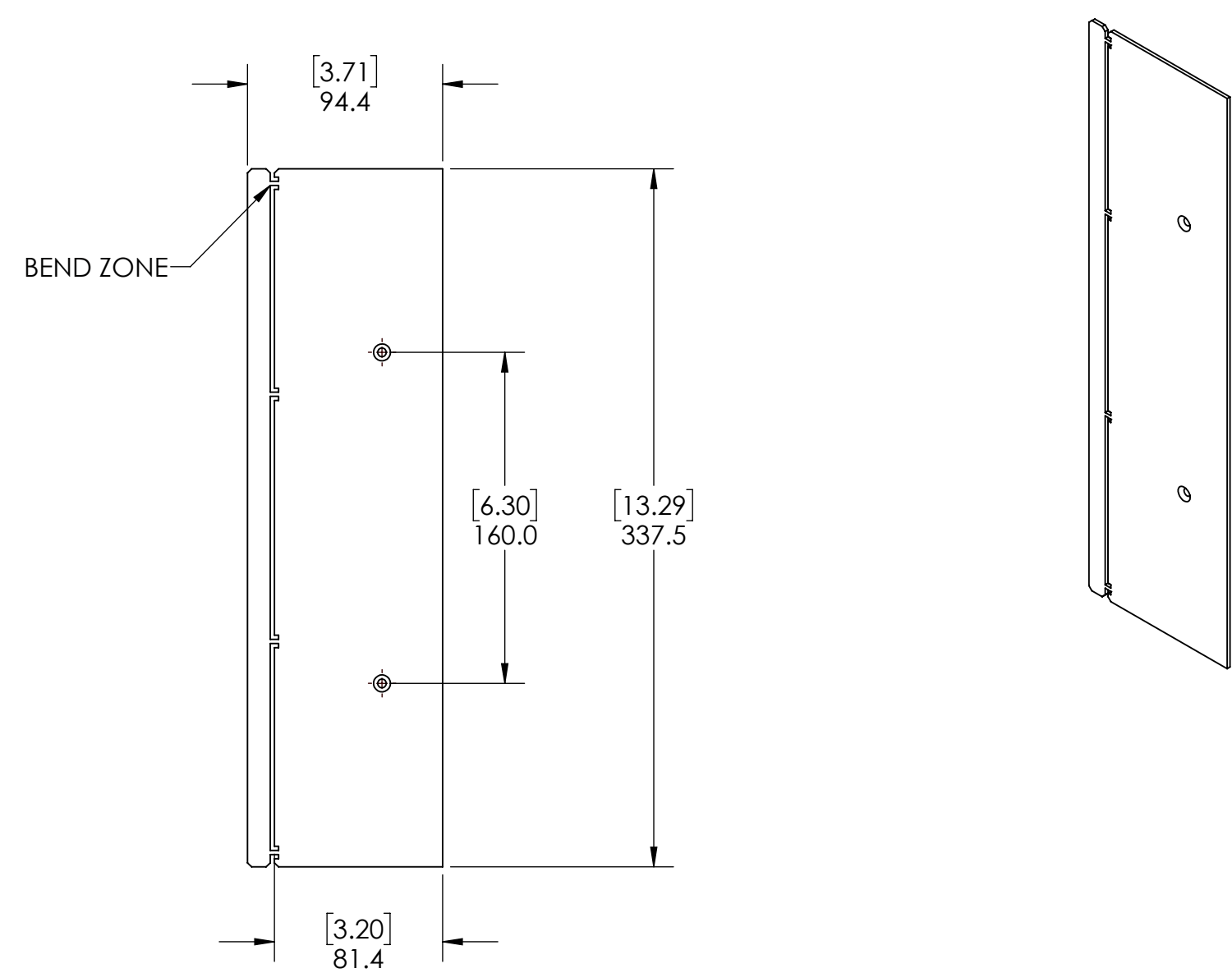

RIGHT TRIM

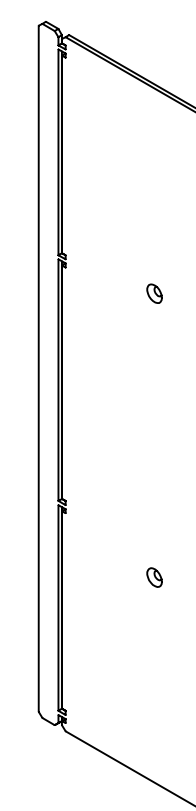
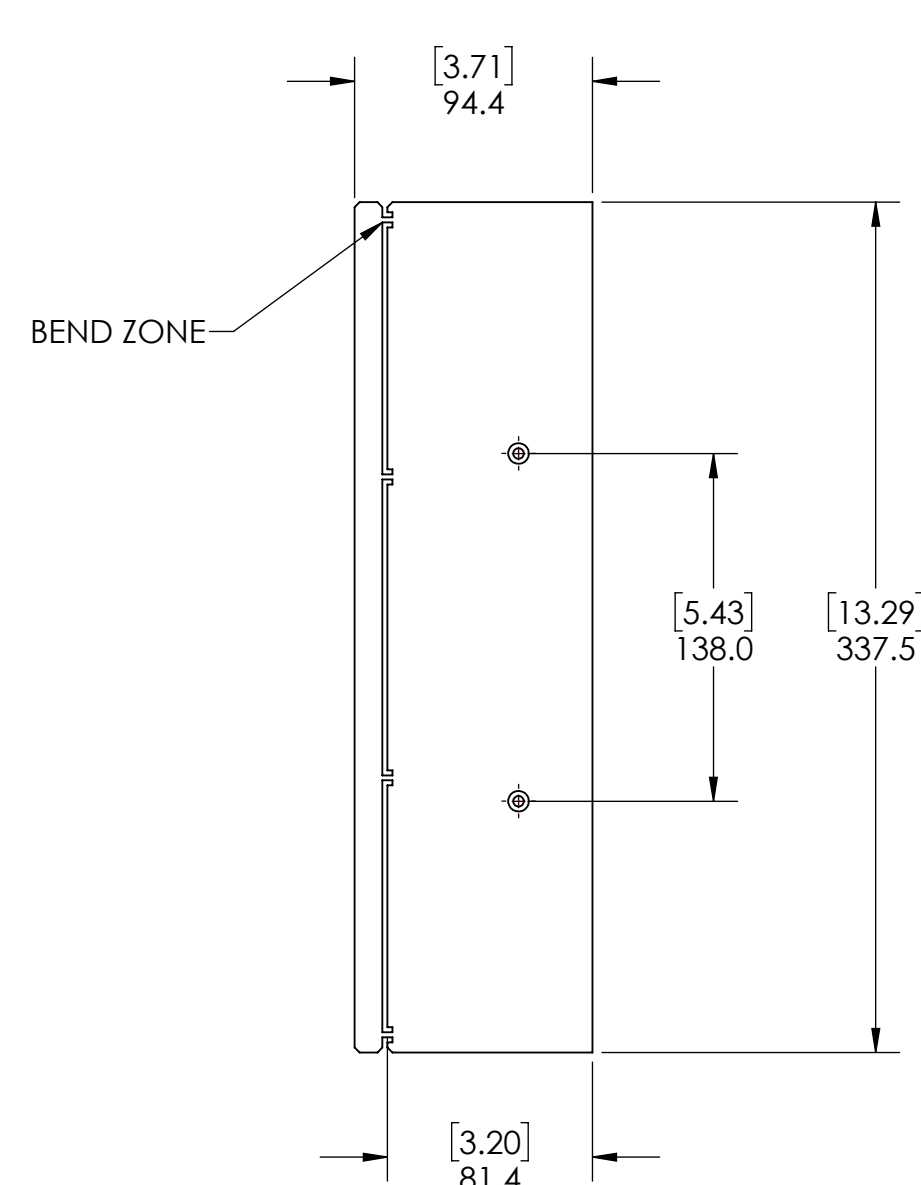

5. TRIM THAT WILL INTERFERE WITH THE WALL DUE TO MOUNT BRACKET ADJUSTMENT POSITION MAY BE BENT AWAY FROM THE COUNTERSINKS AT THE SLOT WHERE INDICATED.
 4. KEEP PERFORATIONS AREAS CLEAR FOR VENTILATION.
 3. REMOVE ALIGNMENT PINS FROM CABINETS ON THE TOP ROW PRIOR TO TRIM INSTALLATION.
 2. ENSURE THE DISPLAYS ARE MOUNTED FLAT, LEVEL, AND PLUMB.
 1. SPECIFICATIONS SUBJECT TO CHANGE WITHOUT NOTICE.
- NOTES: UNLESS OTHERWISE SPECIFIED.