

REVISION HISTORY					
ECO	ZONE	REV.	DESCRIPTION	DATE	APPR'D

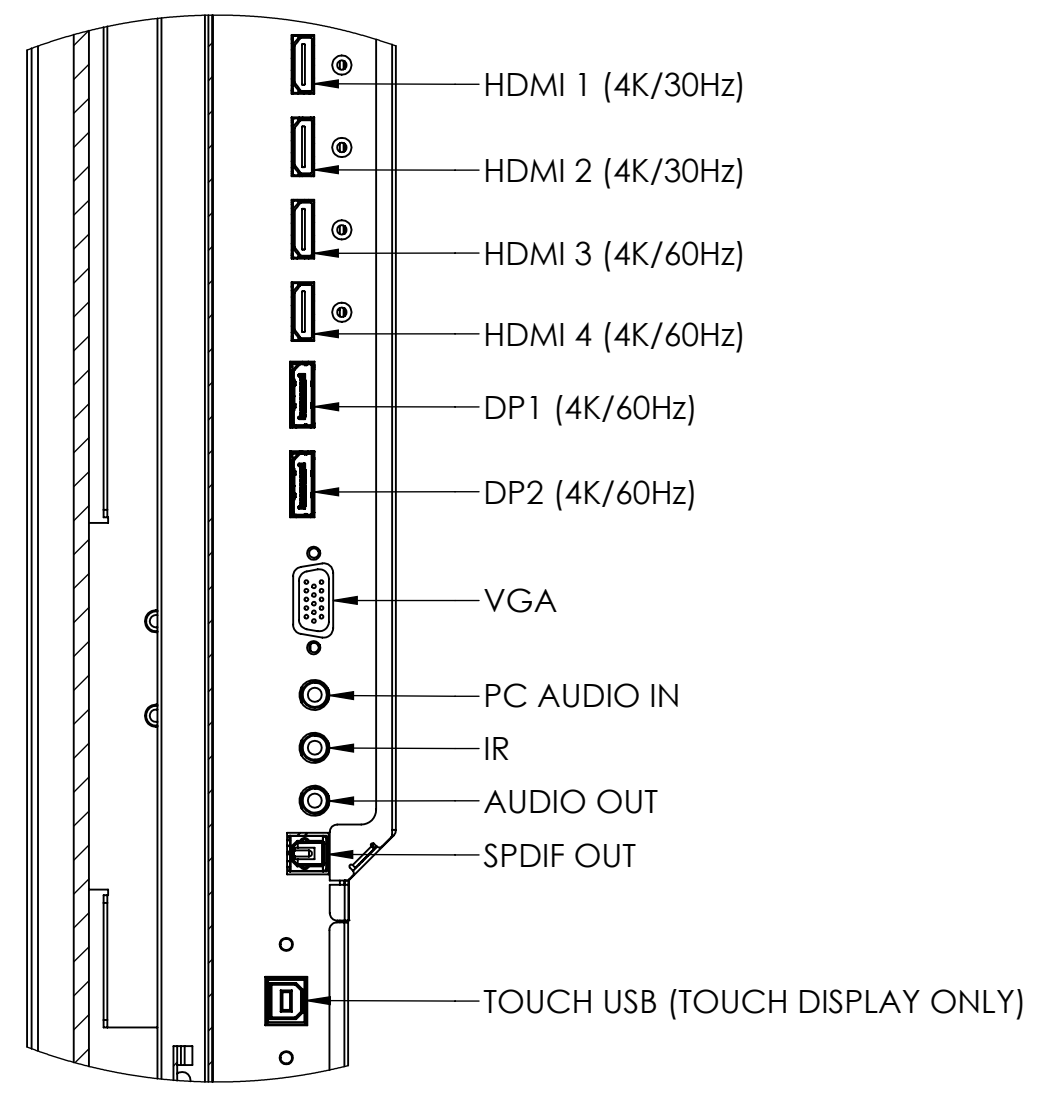

DETAIL A
SCALE 1 : 2

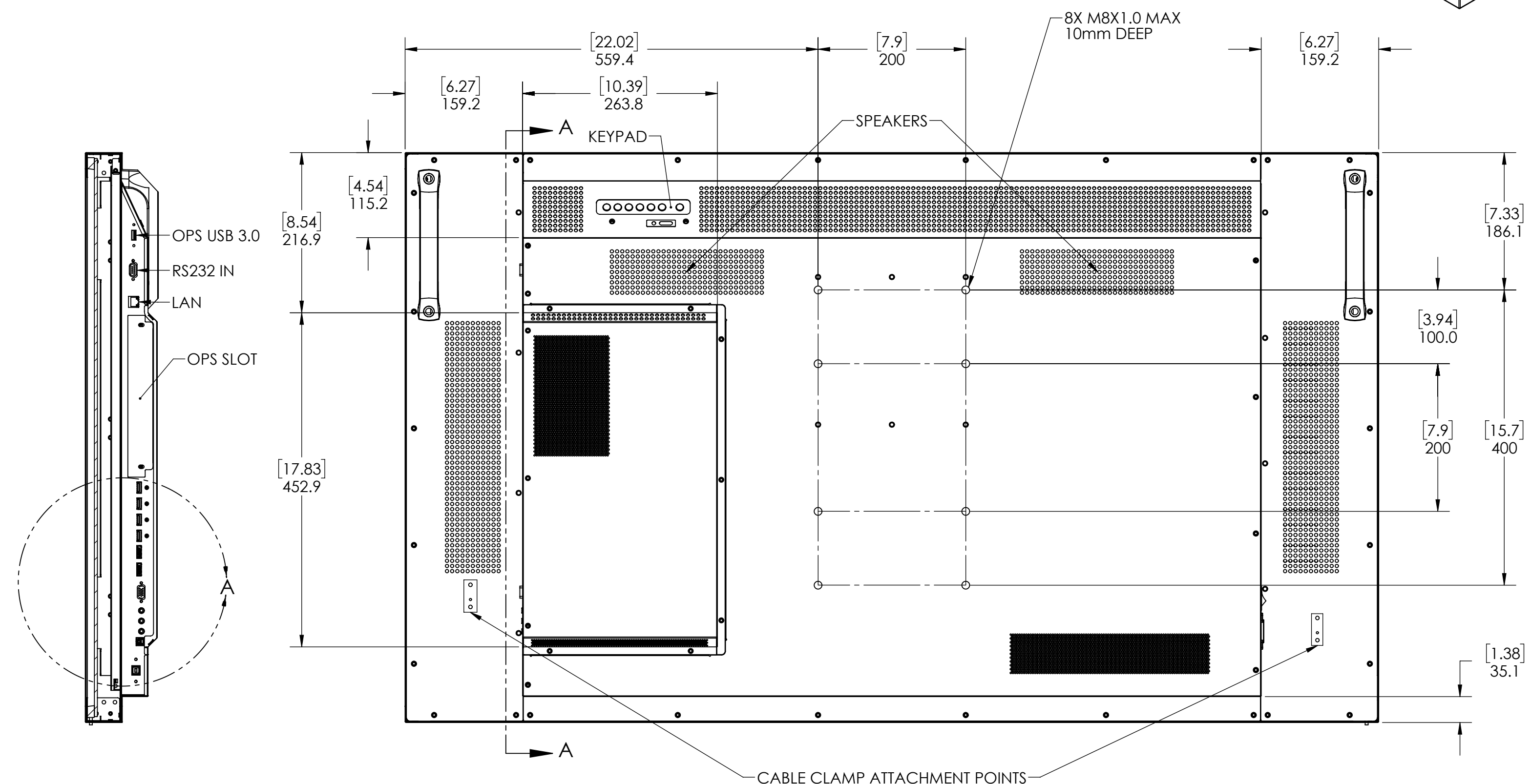
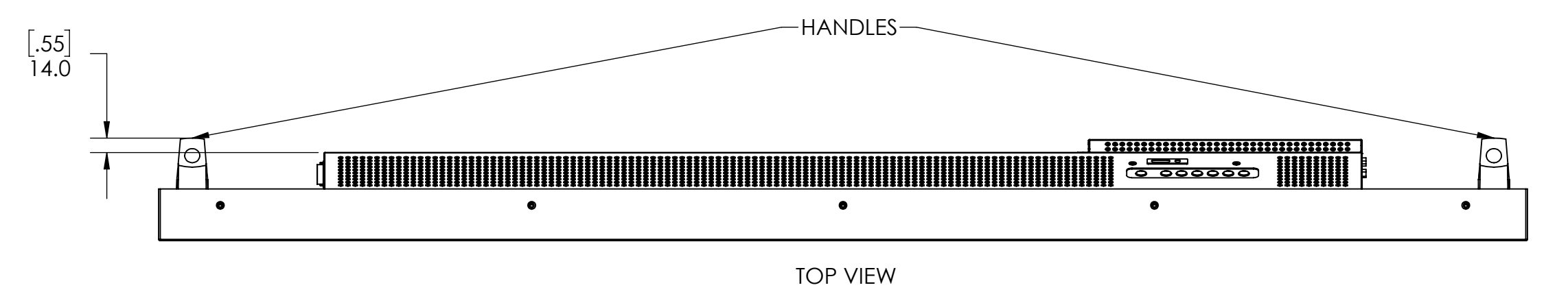
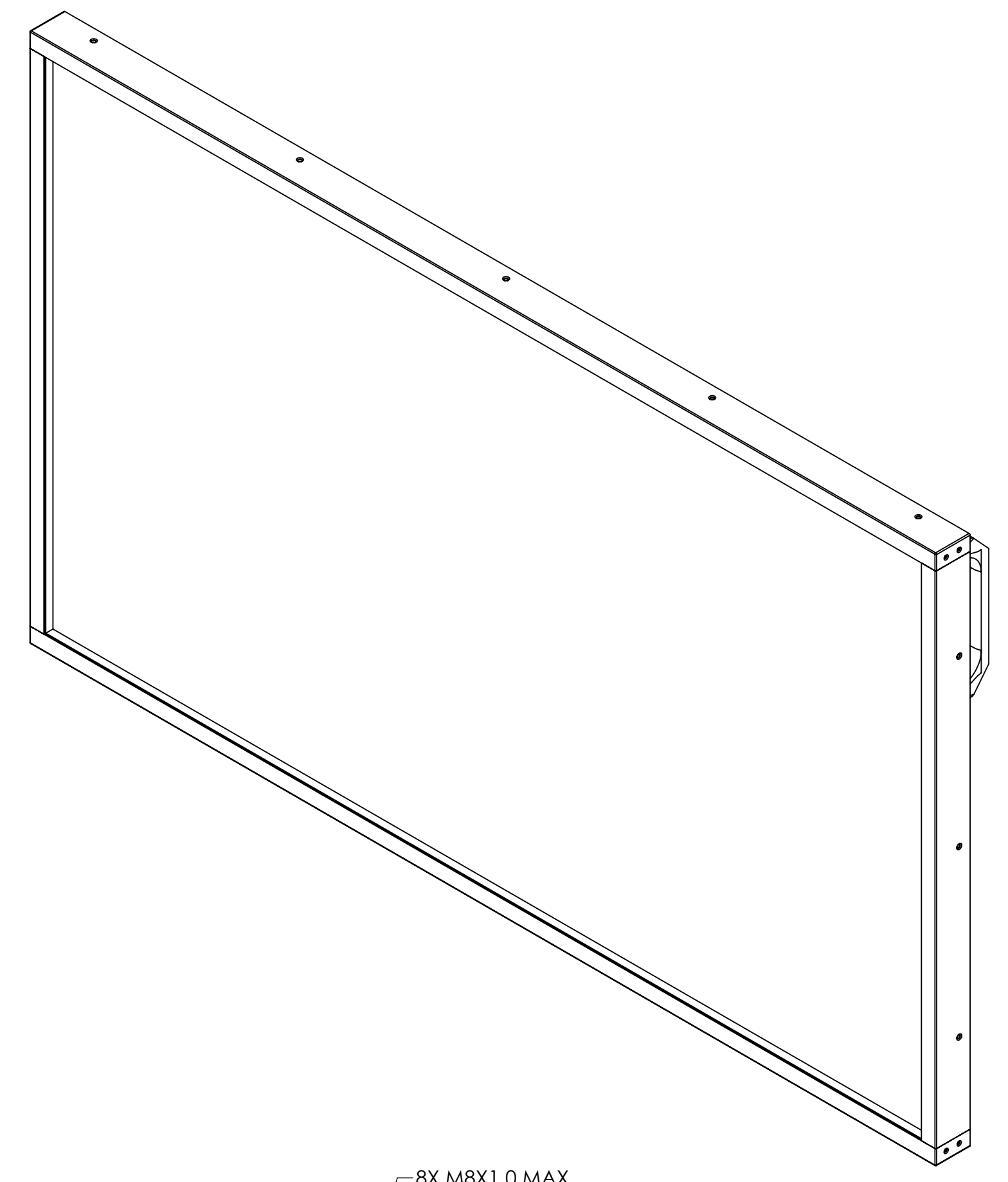

SECTION A-A

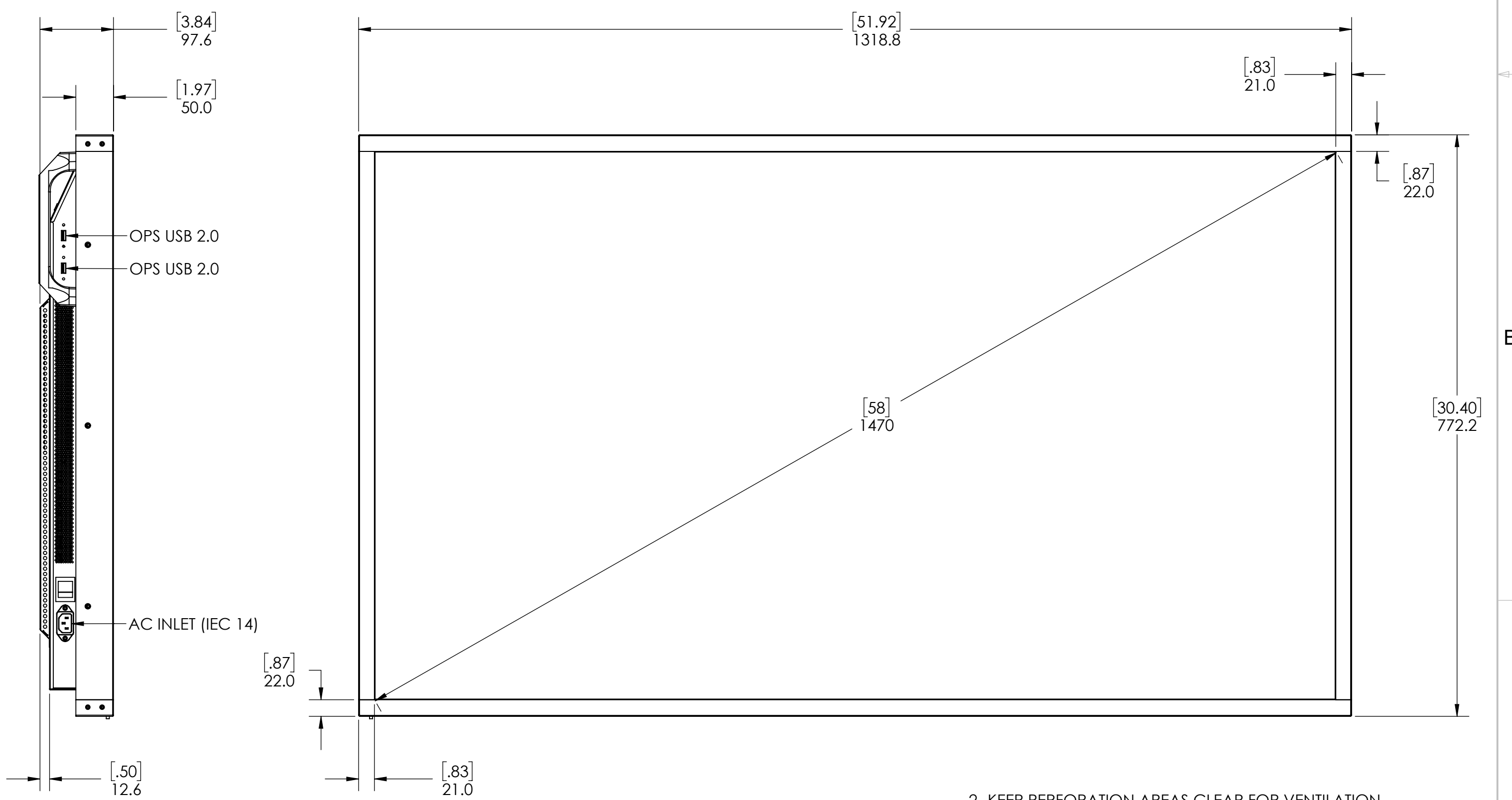

BOTTOM VIEW

- 2. KEEP PERFORATION AREAS CLEAR FOR VENTILATION.
 - 1. SPECIFICATIONS SUBJECT TO CHANGE WITHOUT NOTICE.
- NOTES: UNLESS OTHERWISE SPECIFIED.

UNLESS OTHERWISE SPECIFIED: DIMENSIONS ARE IN MILLIMETERS (INCHES)		ENGR BY	MRW	16JAN18		PLANAR SYSTEMS, INC. 1195 NW COMPTON DRIVE BEAVERTON, OR 97006 USA
TOLERANCES:		DRAWN BY				TITLE
X= ±1	XX= ±.25	CHECKED BY			SIZE	D
.X= ±.5	∠= ±1°	USED ON			SCALE	1:5
DIMENSIONING AND TOLERANCING PER ASME Y14.5M-1994		MATERIAL			PART NO.	-
THIRD ANGLE PROJECTION		FINISH			DRAWING NO.	EP5824K-T OUTLINE
					REV	A
					SHEET	1 OF 1

THIS DRAWING CONTAINS INFORMATION PROPRIETARY TO PLANAR SYSTEMS, INC. ANY REPRODUCTION IN PART OR WHOLE WITHOUT THE WRITTEN PERMISSION OF PLANAR SYSTEMS IS PROHIBITED. THIS DRAWING IS SUPPLIED FOR INFORMATION, IDENTIFICATION, ENGINEERING, EVALUATION, AND/OR INSPECTION PURPOSES ONLY AND MAY NOT BE USED AS BASIS FOR THE MANUFACTURING OF PRODUCTS OR THE FURNISHING OF SERVICES TO PLANAR SYSTEMS OR TO ANY THIRD PARTY UNLESS AUTHORIZED IN WRITING BY PLANAR SYSTEMS.