

REVISION HISTORY					
ECO	ZONE	REV.	DESCRIPTION	DATE	APPR'D

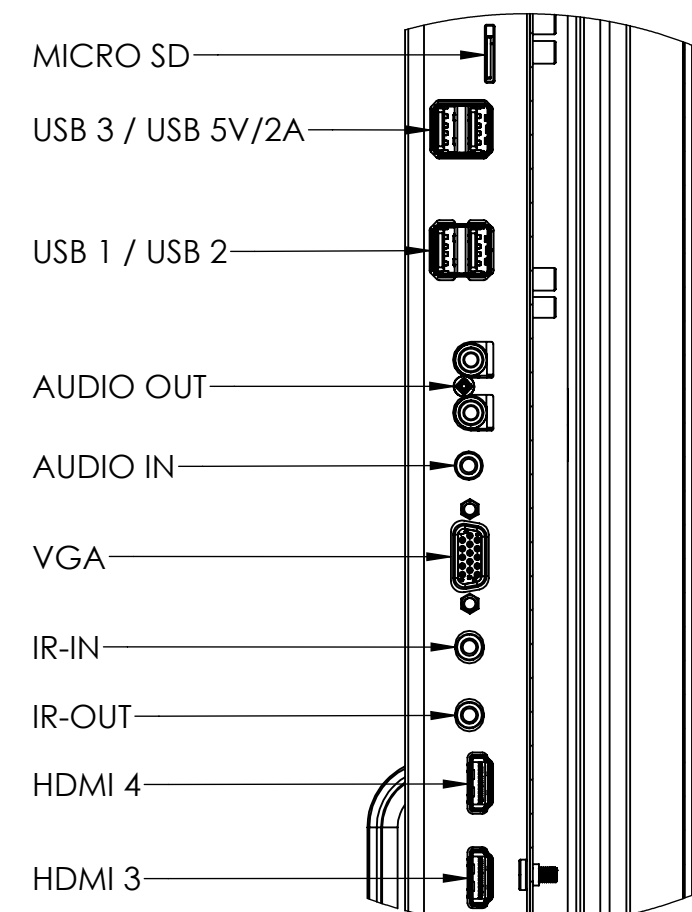

DETAIL C
SCALE 1 : 2

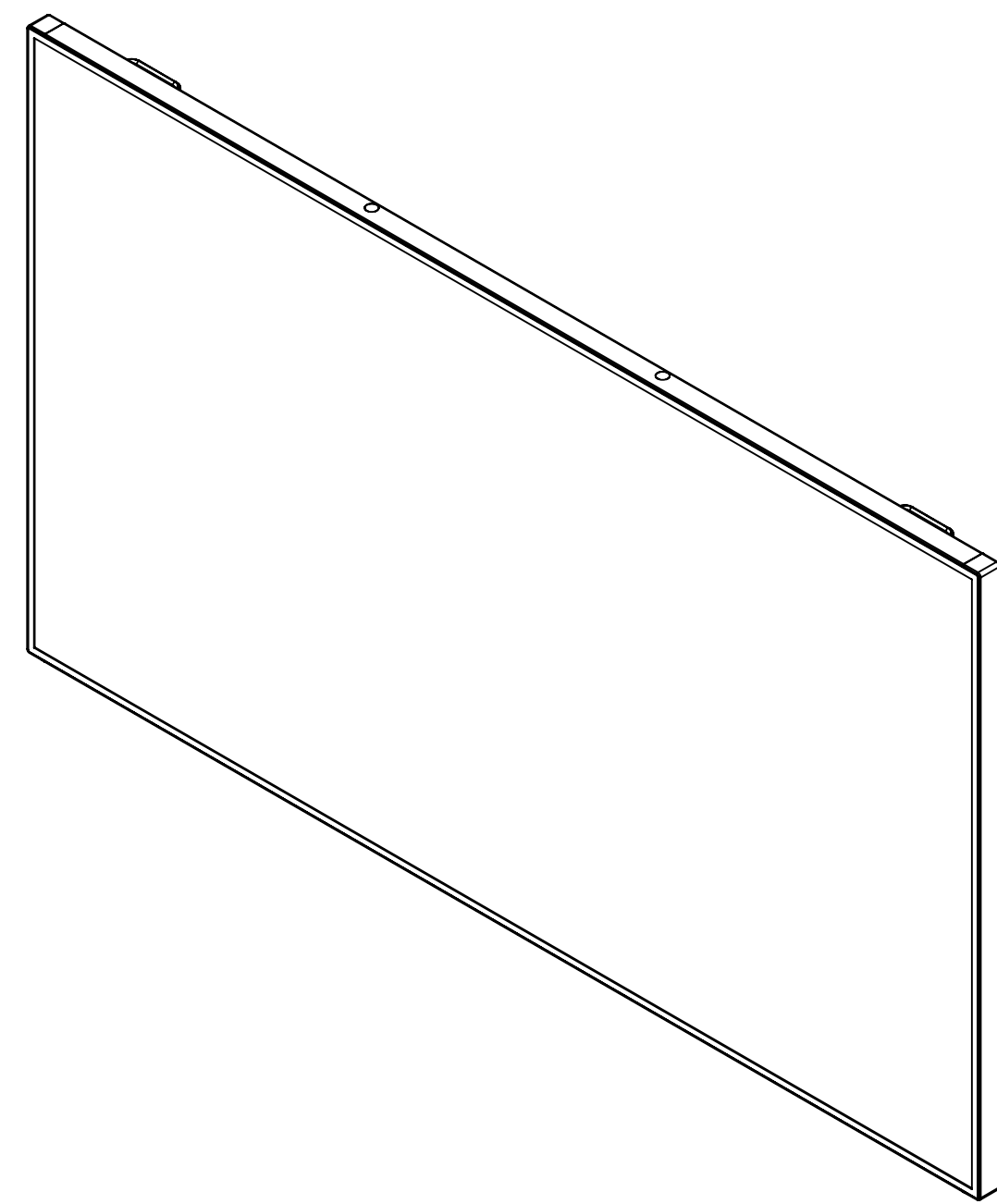
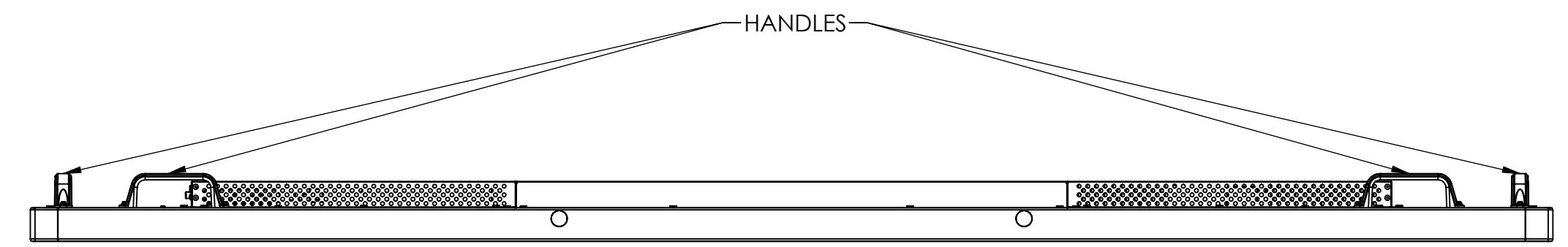

TOP VIEWS

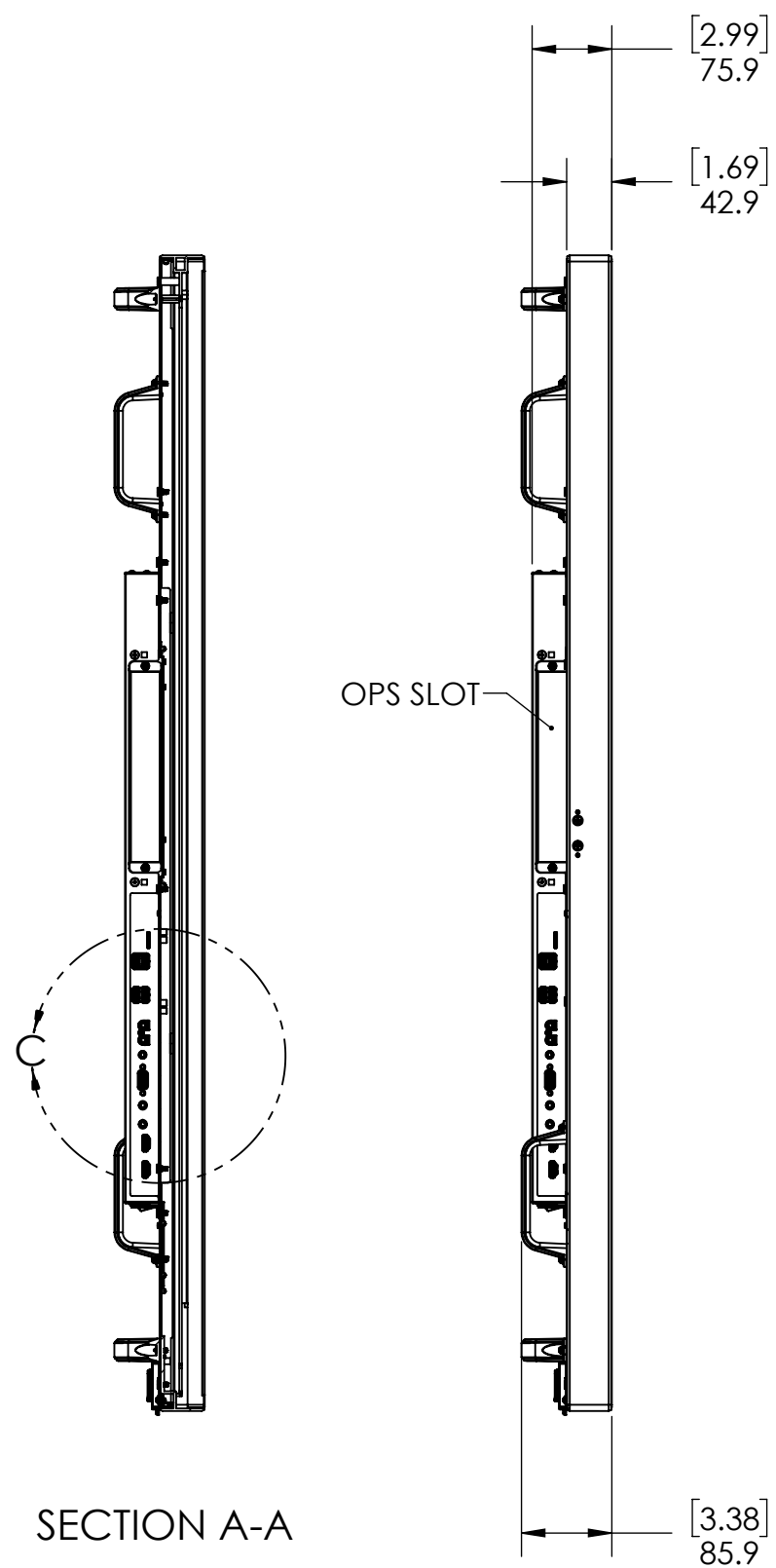
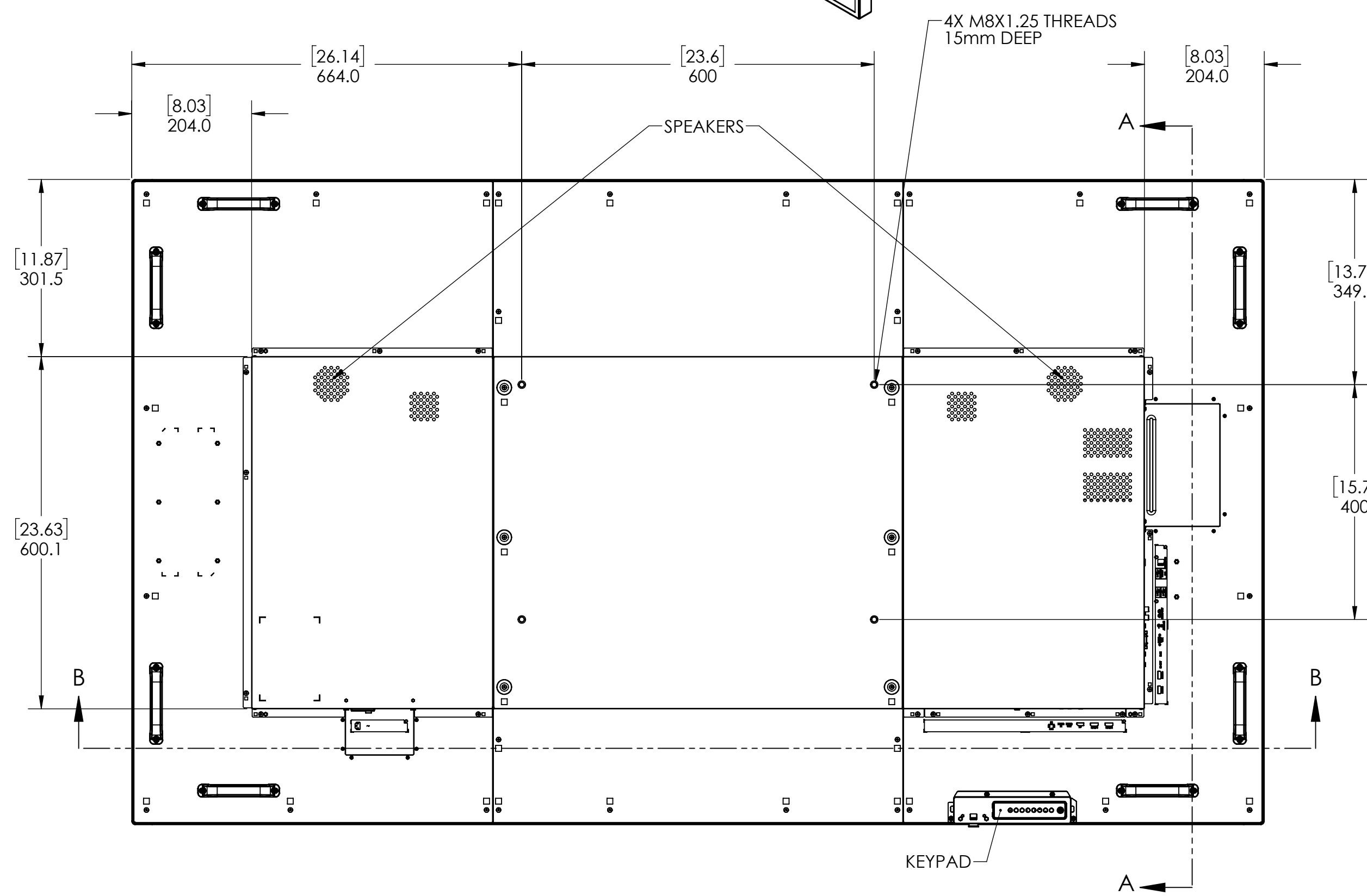

SECTION A-A

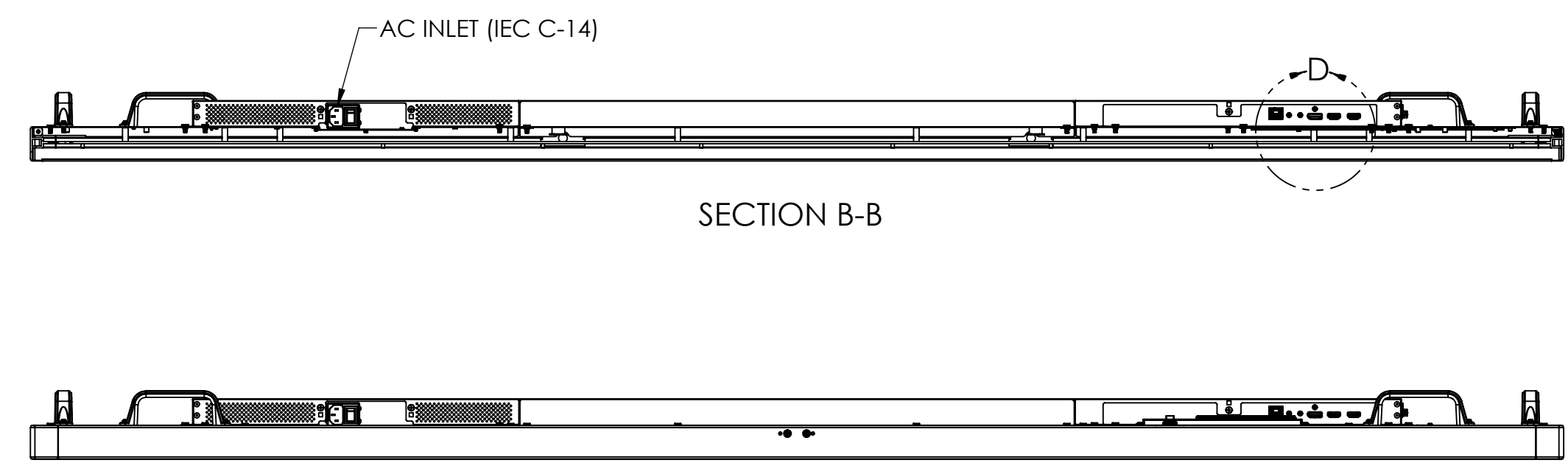
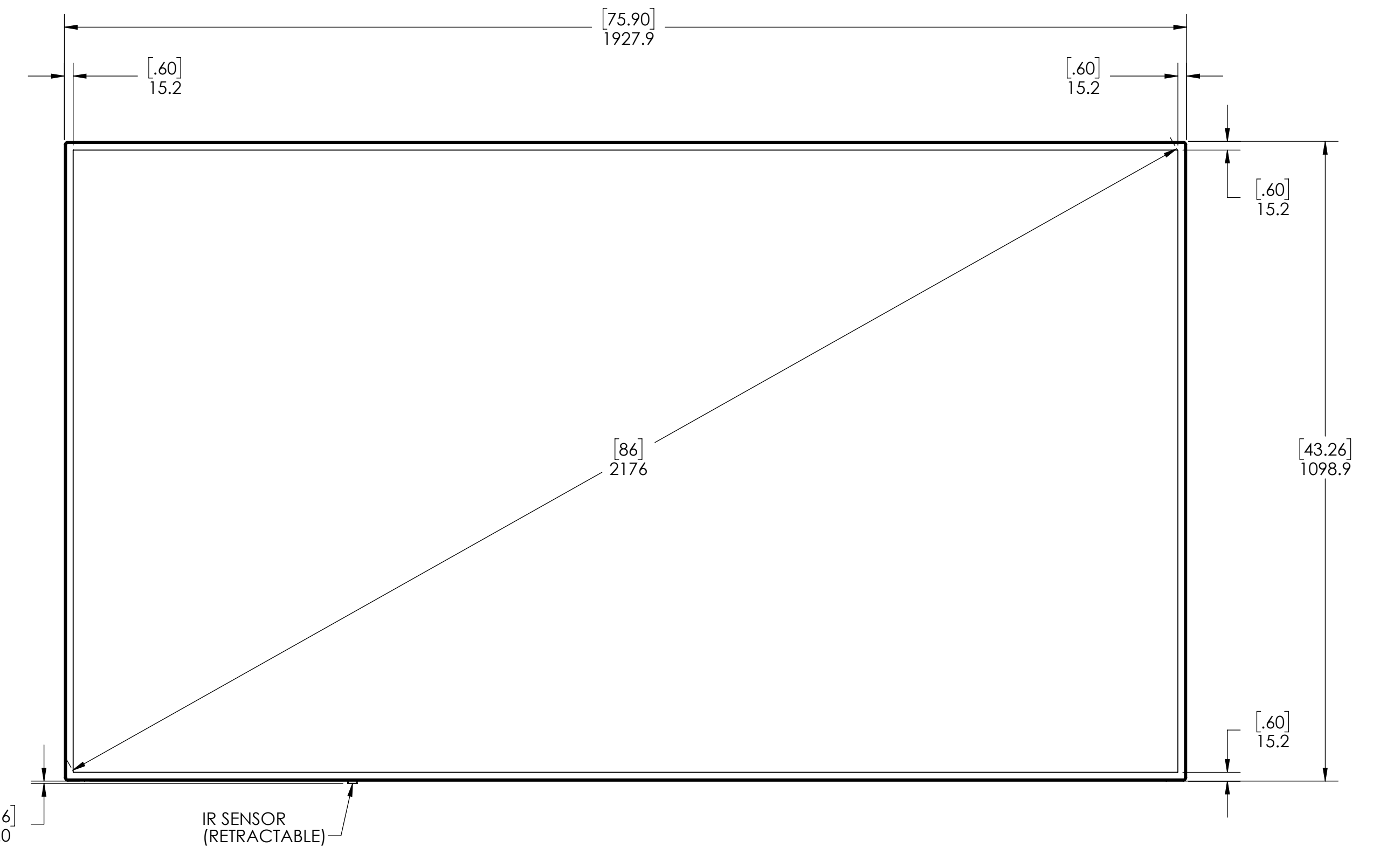

SECTION B-B

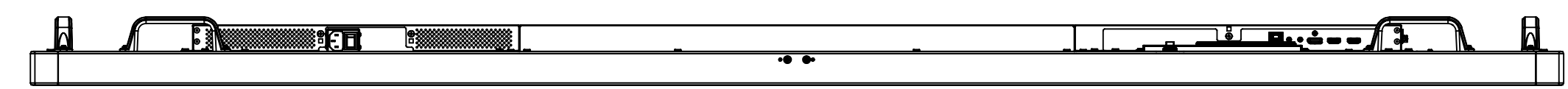

BOTTOM VIEW

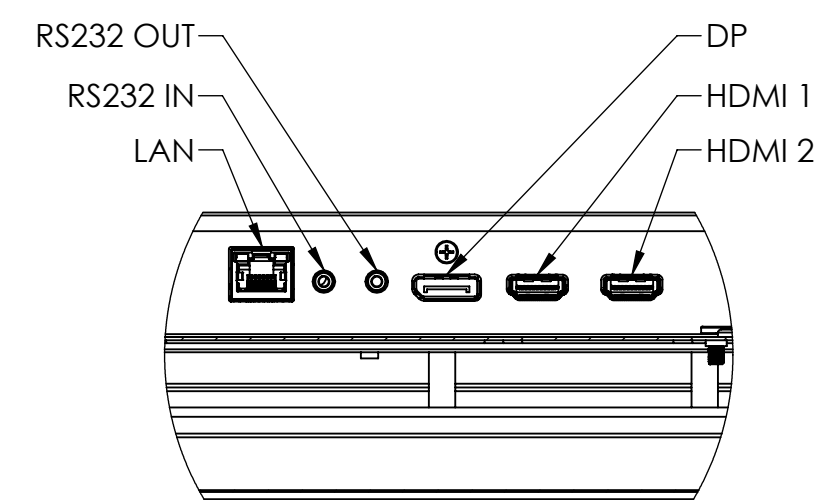

DETAIL D
SCALE 1 : 2

2. KEEP PERFORATION AREAS CLEAR FOR VENTILATION.
 1. SPECIFICATIONS SUBJECT TO CHANGE WITHOUT NOTICE.
 NOTES: UNLESS OTHERWISE SPECIFIED.

<small>UNLESS OTHERWISE SPECIFIED DIMENSIONS ARE IN MILLIMETERS (INCHES)</small> TOLERANCES: X= ±1 XX= ±.25 .X= ±.5 ∠= ±1° <small>DIMENSIONING AND TOLERANCING PER ASME Y14.5M-1994</small>	ENGR BY			<small>PLANAR SYSTEMS, INC.</small> <small>1195 NW COMPTON DRIVE</small> <small>BEAVERTON, OR 97006 USA</small>	
	DRAWN BY	MRW			
	CHECKED BY		23FEB18	TITLE	SL8664K 998-0355-00
	USED ON			SIZE	D
MATERIAL			PART NO.	-	
THIRD ANGLE PROJECTION			DRAWING NO.	SL8664K OUTLINE	
			REV	A	
			SCALE	1:7	
			DO NOT SCALE	SHEET	
				1 OF 1	

THIS DRAWING CONTAINS INFORMATION PROPRIETARY TO PLANAR SYSTEMS, INC. ANY REPRODUCTION IN PART OR WHOLE WITHOUT THE WRITTEN PERMISSION OF PLANAR SYSTEMS IS PROHIBITED. THIS DRAWING IS SUPPLIED FOR INFORMATION, IDENTIFICATION, ENGINEERING, EVALUATION, AND/OR INSPECTION PURPOSES ONLY AND MAY NOT BE USED AS BASIS FOR THE MANUFACTURING OF PRODUCTS OR THE FURNISHING OF SERVICES TO PLANAR SYSTEMS OR TO ANY THIRD PARTY UNLESS AUTHORIZED IN WRITING BY PLANAR SYSTEMS.