Operator's Manual

DuraChill[®] Air- and Water-Cooled 2 and 3 HP Chillers



Table of Contents

Introduction	3
Standard and Optional Features.....	3
Standard Features.....	3
Optional Features.....	3
General Safety Information.....	4
Safety Recommendations.....	4
Unpacking.....	5
Contents.....	5
Controls and Components.....	6
Control Panel.....	6
Front View.....	6
Rear View.....	7
Installation and Startup	8
Site Requirements.....	8
Ambient Temperature and Relative Humidity.....	8
Location.....	8
Clearance.....	8
External Piping.....	9
General Considerations.....	9
Process Fluid Connections.....	10
Facility Water Connections.....	10
Reservoir Drain.....	10
Full Flow Bypass.....	10
Process Coolant.....	12
Electrical Power.....	13
Optional Signal Inputs/Outputs.....	14
RS-232/RS-485 Serial Output.....	14
Remote On / Off Port.....	14
Alarm Output.....	14
Startup.....	15
Facility Water Flow (water-cooled units only).....	15
Filling the Reservoir.....	15
Starting Process Fluid Flow.....	15
Normal Operation	16
Selecting the Temperature Unit.....	16
Displaying and Adjusting the Set Point.....	16
Selecting the Pressure / Flow Rate Display and Units.....	17
Setting Operational Parameters / Limits.....	17
High Temperature Limit (HL).....	19
Low Temperature Limit (LL).....	19
High Ambient Temperature Limit (HA).....	19
Maximum Fluid Pressure (FP).....	19
Minimum Flow Rate (FL).....	20
Flow Rate Calibration (Fc).....	20
Auto-Refrigeration Temperature (AF).....	21
Compressor Band (Cb).....	21
Calibration Offset (c1).....	21
Baud Rate (PC).....	22
Display, Alarm and Error Messages	23
Enabling / Disabling the Local Lockout	25
Routine Maintenance and Troubleshooting	26

Routine Maintenance	26
Condenser, Air Vents and Reusable Filter	26
Fluid Filter	26
Fluid Level	26
Cleaning	26
Temperature Calibration	26
Troubleshooting	27
Diagnostic Mode	28
Technical Information	29
Controller Specifications	29
Performance Specifications – DCA200 Chillers	29
Electrical Specifications – DCA200 Chillers	30
Performance Specifications – DCA300 & DCW300 Chillers	31
Electrical Specifications – DCA300 & DCW300 Chillers	32
Pump Performance	34
RS-232 / RS-485 Communications	35
Equipment Disposal (WEEE Directive)	36
Service and Technical Support	36
PolyScience Chiller Fluids	37
Warranty	37
Appendix	38
Flow Diagram – Air-Cooled Chillers	38
Flow Diagram – Water-Cooled Chillers	39
Wiring Diagram – 208-230V, 1 Phase Air-Cooled Chillers	40
Wiring Diagram – 208-230V, 380-460V 3 Phase Air- and Water-Cooled Chillers	41

Introduction

DuraChill Chillers provide cooling power for demanding applications and serve as an economical alternative to tap water cooling systems. All models feature a microprocessor-based controller, digital Temperature Display (°C or °F), one-touch set point display, and digital Pressure/Flow Rate Display (PSI, kPa, GPM, LPM) with push-Button selection. To optimize cooling efficiency and performance, these sophisticated Chillers also feature a modulated refrigeration system. As a result, temperature stability is greatly enhanced and compressor life extended.

Standard and Optional Features

The PolyScience DuraChill line of industrial Chillers offers exceptional performance, reliability, and operational simplicity. Available in both air- and water-cooled models, these robust self-contained Chillers are engineered to provide accurate temperature control in a wide range of process cooling applications. These powerful Chillers can be configured with a wide variety of standard and optional features, including:

Standard Features

- Process temperature: 41° to 95°F (5° to 35°C)
- Ambient temperature: 60° to 95°F (16° to 35°C)
- Temperature stability: $\pm 0.9^\circ\text{F}$ ($\pm 0.5^\circ\text{C}$)
- Accurate microprocessor control with a digital LED readout
- RS-232 communications interface
- Remote On / Off control (dry contact)
- Pump protection by means of a Full Flow Bypass Valve
- Compressor protection through refrigerant pressure cutouts
- Process protection provided by over-temp/under-temp alarms
- Heavy-duty, locking casters provide easy maneuverability
- Power phase monitor







Optional Features

- Higher-output Centrifugal and Turbine pumps
- Ambient temperatures to 104°F (40°C)
- Other process temperatures 5° to 185°F (-15° to 85°C)
- Process shutoff valves
- RS-485 interface
- Remote temperature control probe
- Stainless steel reservoir
- Audible and Visual Alarms
- Rail or foot mounting
- Tank low level indicator/alarm
- External water filter (side stream)
- DI compatible process piping
- Heaters
- Auto water makeup valve

A Configuration Data Sheet showing how your Chiller is equipped is included with the manual if applicable for optional features.

General Safety Information



When installed, operated, and maintained according to the directions in this manual and common safety procedures, your Chiller should provide safe and reliable temperature control. Please ensure that all individuals involved in the installation, operation, or maintenance of this Chiller read this manual thoroughly prior to working with the unit.









	This symbol alerts you to wide range of potential dangers.
	This symbol advises you of danger from electricity or electric shock.
	This symbol indicates that a hot surface may be present.
	This symbol marks information that is particularly important.
	This symbol indicates alternating current.
	These symbols on the Power Switch indicate that they place the main power supply ON / OFF.
	This symbol on the Power Switch indicates that it places the unit in a standby mode. It DOES NOT fully disconnect the unit from the power supply.

**Read all instructions pertaining to safety, set-up, and operation.
Proper operation and maintenance is the user's responsibility.**

Safety Recommendations

It is the user's responsibility to read and understand all instructions and safety precautions included in this manual prior to installing or operating this equipment. Contact our Customer Service Department with any questions regarding the operation of this Chiller or the information contained in this manual.

	WARNING: All warning labels should be carefully observed. Never remove or obstruct a warning label.
	WARNING: Installation, operation, or maintenance of this equipment should be performed in strict accordance with the instructions outlined in this manual. Failure to follow those instructions may increase the risk of personal injury, damage the equipment, and/or void the warranty.

	WARNING: Be sure to remove power from the equipment, reclaim the refrigeration charge, and relieve any residual pressure before cutting into the refrigeration system.
	WARNING: Do not attempt to operate leaking or damaged equipment.
	WARNING: Service should only be performed by fully qualified personnel. Extreme caution is required as hazards are present when servicing this equipment.
	WARNING: Do not attempt to override the power interlock switch or any other safety feature on this equipment.
	WARNING: Disconnect electrical power before moving unit. Keep unit upright when moving. Always follow your company's procedures and practices regarding safe lifting and relocation of heavy objects.
	WARNING: Make sure the equipment's main power switch is in the OFF position before connecting or disconnecting power. Follow all applicable electrical and safety codes and procedures when connecting power to the unit. Electrical connections should be made by an authorized electrical installer.
	WARNING: This equipment must be properly filled with cooling fluid before use and properly drained before moving or service.
	WARNING: Use only fluids that comply with safety, health, and equipment compatibility requirements. Read the safety data sheet for the fluid being used carefully before use.
	CAUTION: Always operate this equipment within the stated design specifications.

Unpacking

Your Chiller is shipped in a special container. Retain the container and all packing materials until the unit is completely assembled and working properly. Set up and run the unit immediately to confirm proper operation. If the unit is damaged or does not operate properly, contact the transportation company, file a damage claim and contact the company where your unit was purchased immediately.

Contents

- Recirculating Chiller
- Operator's Manual
- Two sets of Inlet/Outlet Adapters, 0.75 inch male NPT

Controls and Components

Control Panel

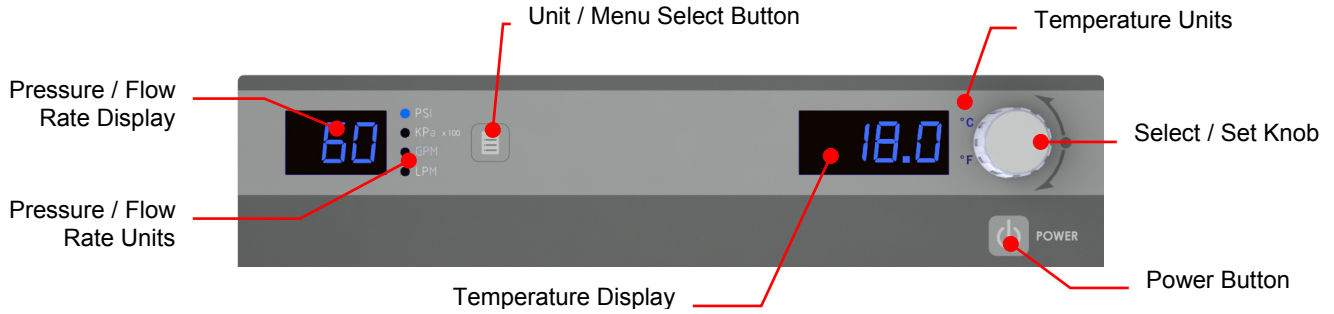

Front View

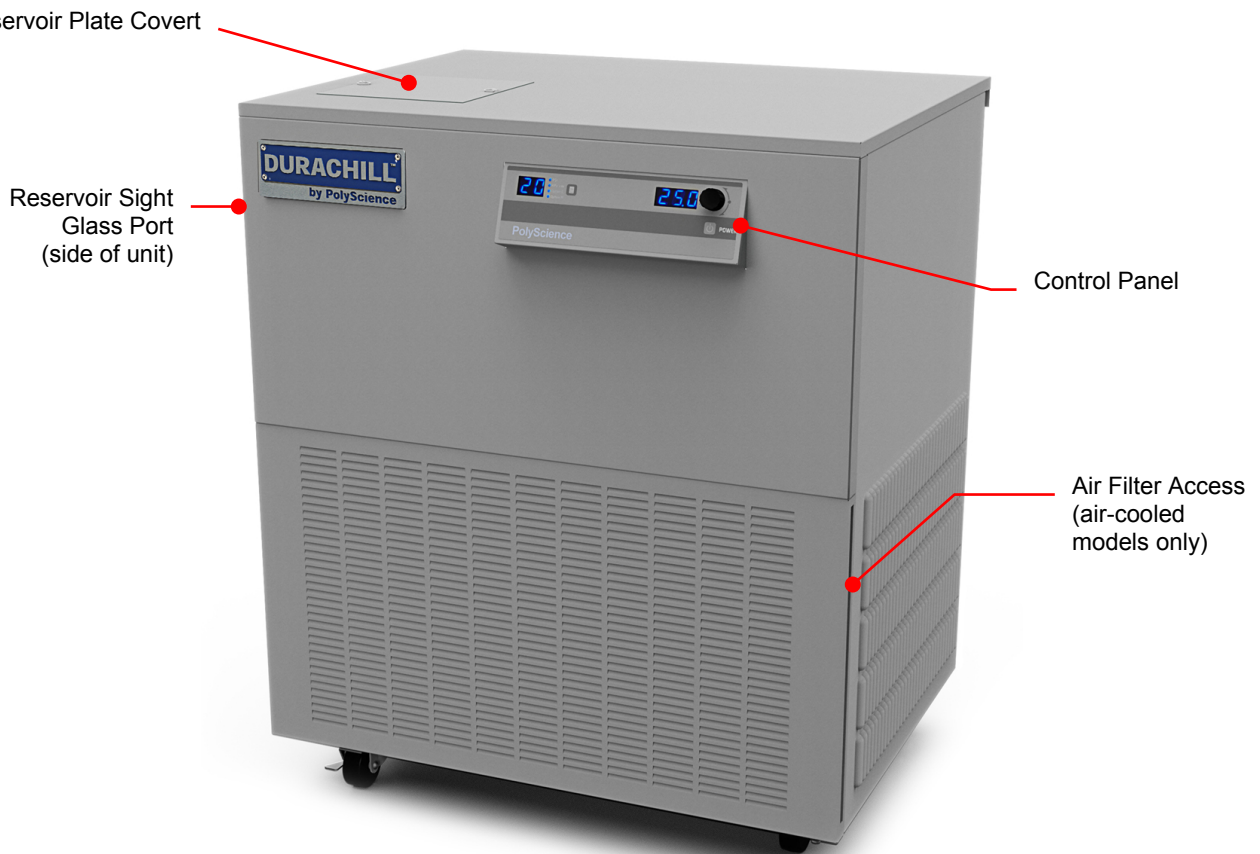

Rear View

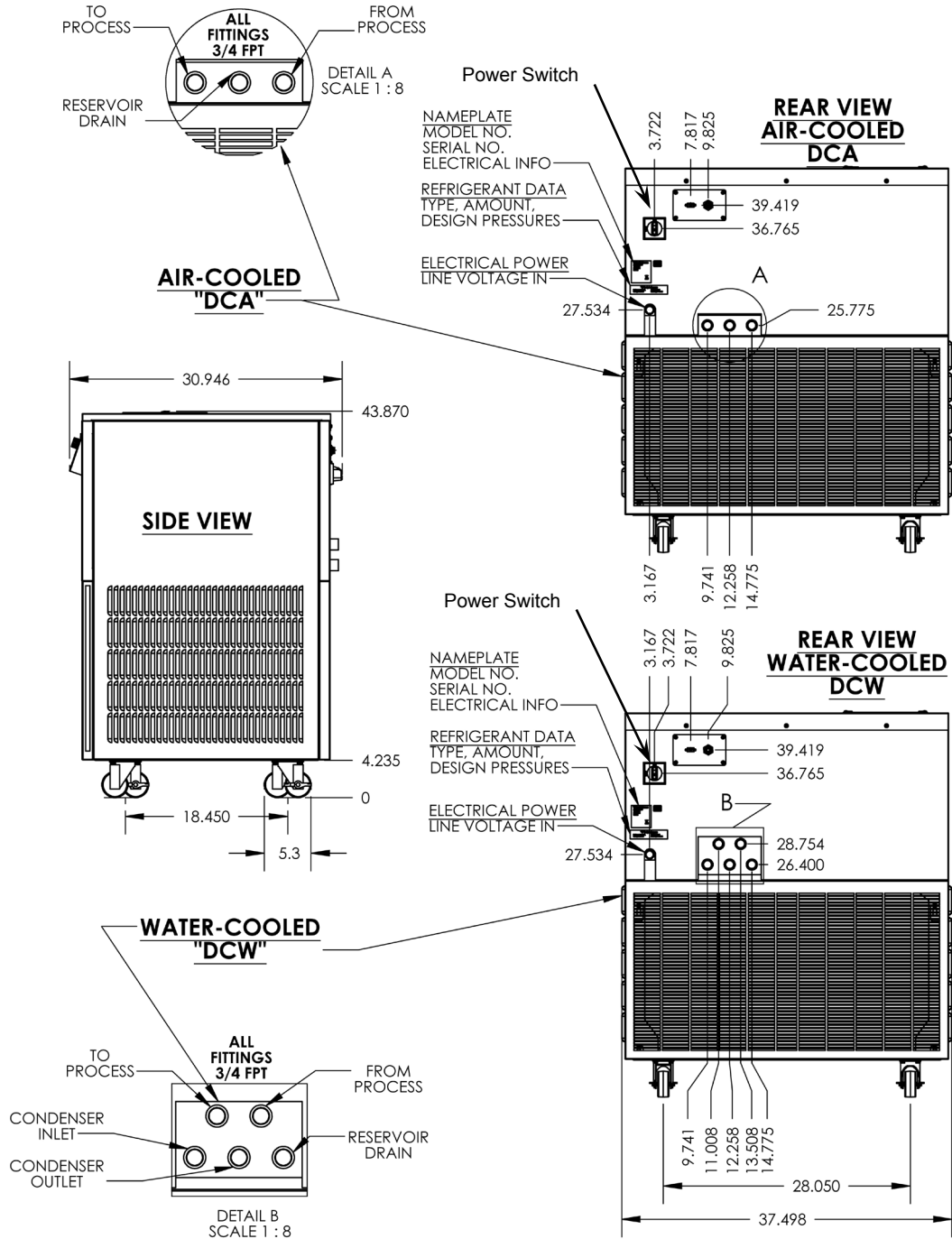

Installation and Startup



WARNING: Be sure all power is OFF before proceeding.

Site Requirements

Ambient Temperature and Relative Humidity

The Chiller is designed for indoor installation in ambient temperatures between 5° and 30°C (41° and 86°F); relative humidity should not exceed 80% (non-condensing).

Location

The Chiller should be installed on a strong, level surface. It should be located as close to possible to the process requiring cooling. It should not be installed closer than 4 feet (1.4 meters) to a heat-generating source, such as heating pipes, boilers, etc. If possible, the Chiller should be located near a suitable drain to prevent flooding in the event of leaks. Do not place it where corrosive fumes, excessive moisture, excessive dust, or high room temperatures are present.

For ease of positioning and maneuverability, the Chiller is supplied with casters. The front wheels can be locked to keep the Chiller in place while in use.

To help prevent voltage drops, position the Chiller as close as possible to the power distribution panel. Avoid voltage drops by using a properly grounded power source wired to meet electrical data plate requirements. The use of an extension cord is not recommended.



NOTE: The Chiller may be located at a level below that of the equipment being cooled. As long as the process remains closed, overflow will not occur when adding cooling fluid to the Chiller reservoir.

Clearance

Adequate clearance should be allowed on the front, sides, and rear of the Chiller for access to connections and components. The front and rear vents of the Chiller must be a minimum of 24 inches (61 cm) away from walls or vertical surfaces so air flow is not restricted.

External Piping

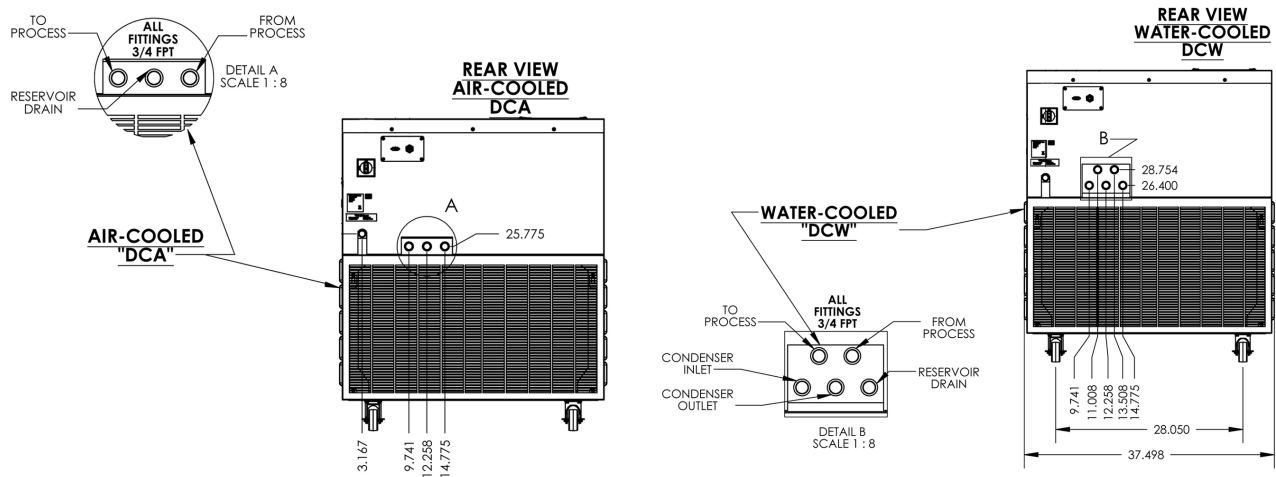

WARNING: All facility water connections must be made by a licensed plumber.

General Considerations

To maintain a safe workplace and avoid leaks, special care should be taken when choosing hoses and connectors for the Chiller. It is the user's responsibility to ensure that the tubing and fittings connected to the Chiller are compatible with the fluid, temperature, and pressure being used.

- Take care when selecting hoses and connections for the Chiller. All external piping, tubing, or hoses should be run full size to limit the potential for external pressure drops. The use of quick-connect fittings is not recommended, as they can cause substantial pressure drops.
- Materials of construction should be compatible with the fluid being used as well as the temperature and pressure at which the unit will operate.
- Where applicable, always use a back-up wrench when making piping connections to the Chiller.
- Pressure Ratings – Hoses should be able to withstand the highest pressure that they will encounter (20 psi / 1.4 bar for centrifugal pumps; 100 psi / 6.9 bar for turbine pumps).
- Flexible Tubing – Avoid tubing that will expand and increase fluid volume when operating at the desired pressure.
- Hose Diameter – The fittings on the Chiller's process fluid lines are female 0.75 in NPT. The facility water fluid inlets and outlets on water-cooled models are female 0.75 inch NPT.
- Facility Water (water-cooled models only) – Should be clean and well maintained. Ideally, the facility water should be tested monthly to ensure a pH level between 7.2 and 7.8. Add algacide if algae growth is present.

Process Fluid Connections

The Chiller has two internally threaded (0.75 inch ID NPT) fittings on the rear of the instrument housing for the process water connections. Two sets of adapters for 0.75 inch hose are supplied with the unit for connecting these fittings to the process piping.

Connect the Chiller's inlet and outlet to the external apparatus with hoses or pipes. The direction of the flow through the system can be controlled by the way the connections are made. Fluid is drawn into the Chiller through the "Inlet" connection; fluid is pumped out of the Chiller through the "Outlet" connection.



NOTE: When Chillers with the standard magnetic drive centrifugal pump are connected to an external apparatus with a built-in shutoff, an external bypass loop assembly (Part No. 510-147) may be needed if operating below 20°C (68°F). This bypass assembly continues flow circulation to and from the pump even though the main flow to the external apparatus has been blocked.

Facility Water Connections



WARNING: The incoming cooling water pressure should be 20 psi / 1.4 bar minimum and 150 psi / 10.3 bar maximum.

Water-cooled Chillers have two internally threaded (0.75 inch ID NPT) on the rear of the instrument housing for the facility water connections. The cooling water supply should be connected to the facility water inlet on the Chiller. The facility water outlet on the Chiller should be connected to the appropriate return or drain, as required.

The cooling water supply may be from city tap water or a cooling tower. The incoming water pressure should be between 20 and 40 psi / 1.4 and 2.8 bar.

Reservoir Drain

A 0.75 inch NPT connection is provided for the reservoir's gravity drain. It should be piped to a drain or receptacle positioned below the bottom of the reservoir. If a receptacle is used, be sure it is of sufficient volume to hold all the coolant in the reservoir, process, and process lines.

Full Flow Bypass

This allows the operator to adjust the maximum operating pressure to the process. For low pressure pumps, the pressure range is 7 to 35 psi (0.5 to 2.4 bar). For high pressure pumps, the pressure range is 30 to 100 psi (2.1 to 6.9 bar). The Full Flow Bypass is located just above the pump.



NOTE: The Full Flow Bypass also protects the pump when running continuously under dead head conditions caused by a blockage in the process or process lines.

Adjusting the Full Flow Bypass Pressure Setting



WARNING: Hazardous voltages are present.

The pressure setting on the Full Flow Bypass is adjusted as follows:

1. Set the minimum allowable flow rate to 0 (see *Normal Operation, Setting Operational Parameters / Limits, Minimum Flow Rate*).
2. Completely block the flow from the Chiller's fluid outlet. This should cause the pressure to rise.

3. Set the Pressure / Flow Rate Display to read in either PSI or kPa (see *Normal Operation, Selecting the Pressure / Flow Rate Display and Units*).
4. Remove the insulation covering the pressure regulating valve cap and then remove the cap. There may be some coolant in the cap; this is normal.
5. Loosen the locknut and then using a flat blade screwdriver, adjust the pressure until the reading on the Pressure / Flow Rate Display matches the desired maximum operating pressure. A clockwise rotation increases pressure; a counter-clockwise rotation decreases pressure.
6. Set the minimum allowable flow rate to the desired value.
7. Tighten the locknut and replace the cap and insulation.
8. Set the Pressure / Flow Rate Display to the preferred reading (GPM, LPM, PSI, kPa).

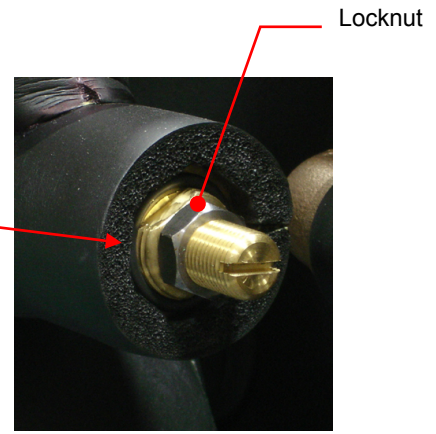
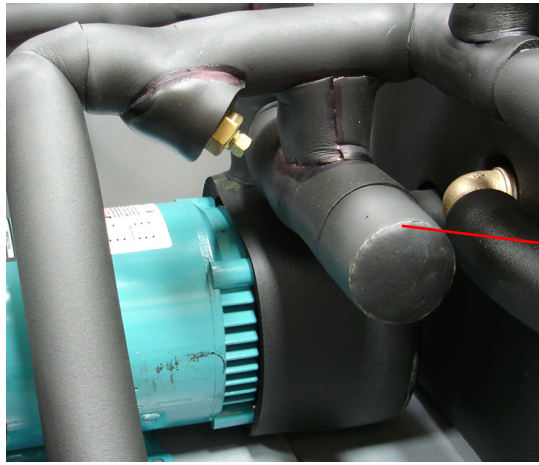

Process Coolant

Suitable Fluids



WARNING: Use only fluids that comply with safety, health, and equipment compatibility requirements. Read the safety data sheet for the fluid being used carefully before use.

The Chiller is designed to accommodate a variety of coolant fluids (water, glycol mixtures, etc). For most applications above 15°C (59°F), distilled water is satisfactory. For operation below 15°C (59°F), the Chiller must be protected with an antifreeze solution. Ethylene glycol (laboratory grade) and water in a 50/50 mixture is satisfactory from +15° to -15°C (59° to 5°F). Select a fluid that is compatible with the Chiller's wetted parts (brass, bronze, stainless steel, EPDM rubber, nylon, PVC).



WARNING: Do not use caustic, corrosive, or flammable fluids.



CAUTION: Operation below 15°C (59°F) requires antifreeze in the circulation fluid. DO NOT use automotive antifreeze as the additives may be harmful to the Chiller's wetted parts.

DO NOT USE the following fluids:

- Automotive antifreeze with additives**
- Hard tap water**
- Deionized water with a specific resistance > 1 meg ohm (except units with the DI water compatible plumbing)
- Any flammable fluids
- Concentrations of acids or bases
- Solutions with halides: chlorides, fluorides, bromides, iodides or sulfur
- Bleach (Sodium Hypochlorite)
- Solutions with chromates or chromium salts
- Glycerin
- Syltherm fluids

** At temperatures above 40°C, additives or mineral deposits can adhere to the heater. If deposits are allowed to build up, the heater may overheat and fail. Higher temperatures and higher concentrations of additives can hasten deposit build up.

Electrical Power



WARNING: Make sure the main power switch is in the OFF position before connecting or disconnecting electrical power from the unit. Follow all applicable electrical and safety codes and procedures when connecting power to the unit. Electrical connections should be made by an authorized electrical installer.



WARNING:

Make certain that the electrical supply is the same voltage and frequency as your unit (see identification label).

Make sure electrical connections comply with all applicable electrical codes.

Ground the Chiller in accordance with NEC Article 250.

Operating voltage must be within $\pm 10\%$ of the data plate rating.

Phase imbalance must be below 5%.



WARNING: DO NOT apply power to the Chiller until the unit is ready for Startup



CAUTION: DO NOT apply power to the Chiller until the Reservoir has been filled. When Controller power is turned On, the pump automatically begins pumping. If the Reservoir has not been filled, the pump could be damaged.

Use the voltage and amperage requirements specified on the identification label on the rear of the Chiller.

Remove the three screws securing the Chiller's rear top panel and remove it. Remove the right side panel by pushing up from the bottom to unhook the latching tabs. Remove the insulating cover over the electrical compartment.

Bring properly sized power leads and ground from a fused disconnect to the unit. Use dual-element fuses in the disconnect, sized according to National Electrical Code recommendations.

3 Phase Units: The Chiller is equipped with a phase monitor that prevents startup if phase sequence is incorrect. It will also turn the Chiller OFF in the event of a loss of one phase and/or prevent Chiller operation if there is a voltage mismatch between any two phases greater than 8%. Be sure to connect electrical lines in proper sequence, i.e.: L1, L2, and L3.

You may want to verify that electrical power to the unit is ON before reinstalling the side and rear panels.



WARNING: DO NOT remove the ground wire while diagnosing any power supply problems.

Optional Signal Inputs/Outputs

RS-232 / RS-485 Serial Output

This option allows you to remotely control the Chiller and/or output temperature readings to an external recorder or other auxiliary device. The maximum communications distance for Chillers equipped with the RS232 option is 50 feet (15 meters). The maximum distance for units equipped with the RS485 option is 4000 feet (1200 meters). A 9-pin D-connector is provided on the rear of the instrument enclosure for this connection.

Remote On / Off Port

This option allows you to connect a remote on/off switch or other remote control device to the Chiller. The Chiller is ON when the contact is open; it is OFF when the contact is closed. A 10-ft (3 m) cord with 5-pin mating plug is provided.

Alarm Output

This allows the operator to connect a remote alarm device to the Chiller. The alarm output consists of normally open (NO) and normally closed (NC) contacts which are switched whenever an alarm, fault, or error condition is detected or when the Chiller is OFF. A 10-ft (3 m) cord with 5-pin mating plug is provided.

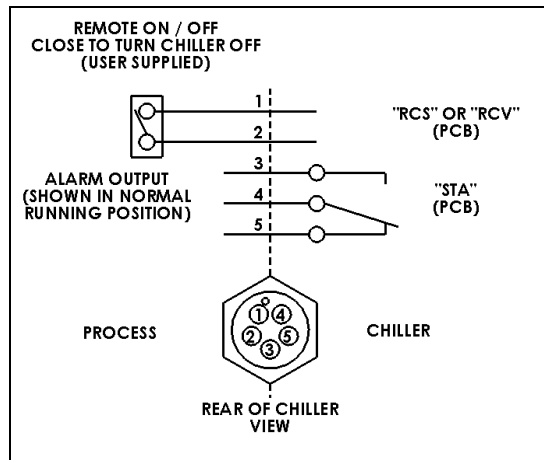

Remote On / Off and Alarm Output

Startup

Facility Water Flow (water-cooled units only)

1. Open the valves to the facility water supply and return.
2. Check for leaks.

Filling the Reservoir

1. Remove the reservoir cover plate (located on the top of the Chiller) and reservoir cap.
2. Using a funnel, add fluid until it is approximately 2 inches (5.1 cm) below top of reservoir.
3. Once the fluid level is about 2 inches (5.1 cm) below the top of the reservoir, remove the funnel but do not replace the cap at this time.

Starting Process Fluid Flow

1. Place the Power Switch located on the rear panel of the Chiller in the ON position. The display on the front panel will respond by showing standby (....). If there is no response, check that the unit is connected to working electrical power and that Power Switch on the rear of the Chiller is in the ON position.
2. Press the Power Button on the front panel. The system startup sequence will begin and proceed as follows:
 - The pump will turn on and fluid will begin circulating through the system.
 - The set point temperature will appear briefly on the Temperature Display; after a few seconds, it will be replaced by the actual fluid temperature.
 - 15 to 20 seconds after power up, the compressor will begin operating.
3. Check for leaks.
4. With the pump running, the reservoir's fluid level will drop as the process and/or process cooling lines fill with fluid. Slowly add fluid to the reservoir until the liquid level remains stable.
5. Replace the reservoir cap and cover plate.

Normal Operation



NOTE: The Chiller incorporates a special “lockout” feature that can be enabled to prevent unauthorized or accidental set point and other operational changes. This feature is described in detail under “*Enabling / Disabling the Local Lockout.*” It should not be enabled until all operational parameters have been set.

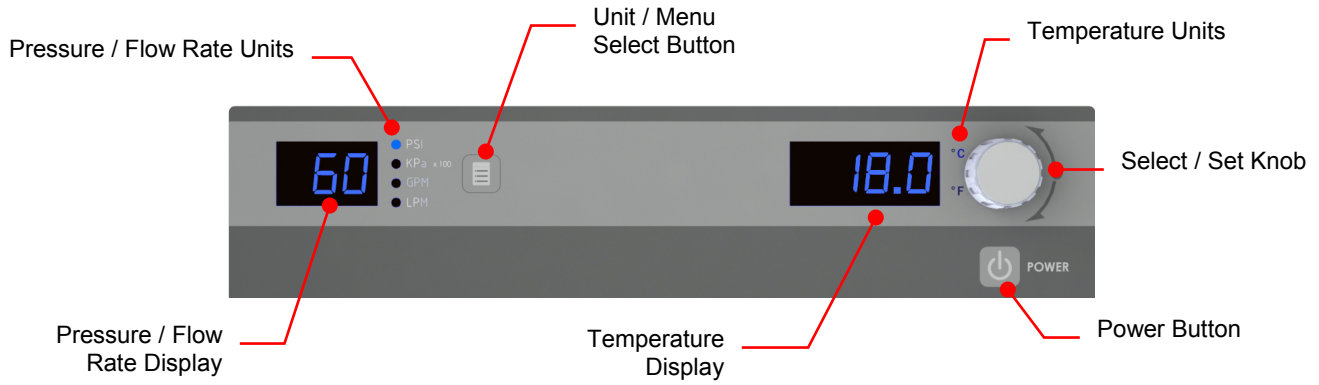

Selecting the Temperature Unit (°C or °F)

The LEDs adjacent to the Temperature Display indicate the unit (°C or °F) used for Temperature Displays. To change from °C to °F or vice versa, proceed as follows:

To change to °F — Place the Power Switch on the rear of the instrument in the OFF position. Press and hold the Units/Menu Select Button while returning the Power Switch to the ON position.

To change to °C — Place the Power Switch on the rear of the instrument in the OFF position. Press and hold the Power Button on the front panel while returning the Power Switch to the ON position.



IMPORTANT: All user settings, except baud rate and calibration offset, return to the original factory defaults when the temperature unit is changed. The Chiller’s temperature set point and various alarm settings should be reset to the desired values.

Displaying and Adjusting the Set Point

Press the Select/Set Knob on the front panel. The current set point temperature will be displayed, and the decimal point at the bottom right of the display will flash, indicating that the temperature can be changed.

Rotate the Select/Set Knob until the desired set point temperature is displayed. The setting is accepted after the Select/Set Knob is pressed a second time or automatically after a few seconds of inactivity.



NOTE: Temperature set point cannot be changed when the local lockout is enabled. See “*Enabling / Disabling the Local Lockout*” .

Selecting the Pressure / Flow Rate Display and Units

The Chiller can be set up to display either fluid pressure (in PSI or kPa) or flow rate (in GPM or LPM). Pressing the Units/Menu Select Button briefly toggles through the available selections.



NOTE: The metric pressure reading displayed must be multiplied by 100 for the actual kPa value.



NOTE: The flow rate readout is intended as a reference only. If accurate flow readings are required, an external flow meter is recommended.

Setting Operational Parameters / Limits

The Chiller's various operational parameters, such as temperature, flow rate, and pressure alarm values, are all user-adjustable. They are accessed by pressing and holding the Units/Menu Button until HL appears on the Pressure/Flow Rate Display. Pressing and releasing the Units/Menu Button once HL appears allows you to scroll through the various parameters; rotating the Select/Set Knob allows you to change the displayed setting. You can accept the displayed value by either pressing the Select/Set Knob or allowing the display to timeout.

Operational parameter limit alarms will shut down the compressor, fan, pump, and heaters. Some temperature values are only displayed and settable in °C



NOTE: Some parameters listed may not be included in your version of software.



NOTE: The Ranges and Default Settings shown are for standard models. Ranges and Default Settings for your unit may differ depending on the options selected.

Menu Item	Description	Choices / Ranges	Default Setting
HL	<p>High Temperature Limit — Limits the maximum allowable set point temperature. Audio and visual alarm indicators are activated when the measured fluid temperature reaches the HL temperature setting.</p> <p>NOTE: EHL will appear on the display if the High Limit value is set below the current set point.</p>	<p>68° to 104°F 20° to 40 °C</p>	<p>95°F 35 °C</p>
LL	<p>Low Temperature Limit — Limits the minimum allowable set point temperature. Audio and visual alarm indicators are activated when the measured fluid temperature reaches the LL temperature setting.</p> <p>NOTE: ELL will appear on the display if the Low Limit value is set above the current set point.</p>	<p>10° to 59°F -12° to +15°C</p>	<p>0.0°C</p>

Menu Item	Description	Choices / Ranges	Default Setting
HA	<p>High Ambient Temperature Limit — Maximum ambient temperature limit. Displayed and settable only in °C. Should the ambient temperature rise above the HA value, the audio and visual alarms will activate and the compressor, heater, fan, and pump will turn off.</p> <p>NOTE: Chiller's rated cooling capacity is dependent on an ambient temperature of 20°C (68°F). Performance will decrease as the ambient temperature rises. Continuous operation at ambient temperatures above 40°C (104°F) is not recommended.</p>	<p>+30 to 45°C</p> <p>Note: Always displayed and set in °C</p>	40°C
FP	<p>Maximum Fluid Pressure — Maximum allowable fluid pressure; settable in either PSI or kPa. Should the fluid pressure rise above the maximum fluid pressure value, the audio and visual alarms will activate and the compressor, heater, fan, and pump will turn off.</p> <p>NOTE: The Chiller also incorporates a built in pressure regulated bypass valve. It will maintain a maximum outlet pressure by diverting flow of the process fluid to the reservoir. The bypass valve may be adjusted by the customer.</p> <p>CAUTION: Maximum operating pressure for the Chiller is 100 PSI / 6.9 bar. Different pumps have different maximum operating pressures.</p>	<p>10 to 100 PSI 69 to 690 kPa (display value x 100)</p>	<p>80 PSI 5.5 x 100 = 550 kPa</p>
FL	<p>Minimum Flow Rate — Minimum allowable flow rate; settable in either GPM or LPM. Should the fluid flow rate drop below the minimum value, the audio and visual alarms will activate, and the compressor, heater, fan, and pump will turn off.</p>	<p>0 to 2 GPM 0 to 7.5 LPM</p>	<p>0.0 GPM (0.2 GPM optional) 0.0 LPM (0.1 LPM optional)</p>
Fc	<p>Flow Rate Calibration — Allows adjustment of the displayed flow rate to match that of a known standard.</p>	0 to 99.9 gain	Nominal flow
AF	<p>Auto-Refrigeration Set Point — The upper temperature at which the refrigeration system will activate; displayed and settable in °C only. There will be no refrigeration or cooling at set points above the AF setting.</p>	<p>No heater option 20° to 40°C With heater option 20° to 50°C</p>	<p>No heater option 40°C With heater option 50°C</p>
Cb	<p>Compressor Band — The temperature at which the compressor will turn off. This protects the fluid temperature from dropping too low during periods of low or no heat load. The compressor turns back on when the temperature rises above the set point.</p>	-06° to -03°C	-06°C
°C	<p>Calibration Offset — Allows adjustment of the displayed temperature to match that of an independent traceable standard; displayed and settable in °C only.</p>	±1.9°C	0.0°C
PC	<p>Communications Baud Rate — Selects the baud rate for serial (RS232/RS485) communication.</p>	24 (2400), 48 (4800), 96 (9600) or 192 (19200)	96

High Temperature Limit (HL)

This menu item serves two functions. First, it establishes the maximum allowable set point temperature and thus helps prevent an operator from inadvertently selecting a temperature set point above a pre-established value. Secondly, it serves as a high temperature alarm, automatically activating both audio and visual alarm indicators if the measured fluid temperature reaches the HL setting. This also causes the compressor, heater, fan, and pump to turn off.

To change the high limit value, rotate the Select/Set Knob until the desired value is displayed.

HL		35	
----	---	----	---

Low Temperature Limit (LL)

This menu item also serves a dual function. First, it establishes the minimum allowable set point temperature and thus helps prevent an operator from inadvertently selecting a temperature set point below a pre-established value. Secondly, it serves as a low temperature alarm, automatically activating both audio and visual alarm indicators if the measured fluid temperature drops to the LL setting. This also causes the compressor, heater, fan, and pump to turn off.

To change the low limit value, rotate the Select/Set Knob until the desired value is displayed.

LL		0.0	
----	---	-----	---

High Ambient Temperature Limit (HA)

	NOTE: This value is always set in °C.
--	--

This menu item protects the Chiller from overheating due to a high ambient temperature. Should the ambient temperature rise above the limit value, the audio and visual alarms will activate and the compressor, heater, fan, and pump will turn off.

To change the high ambient temperature value, rotate the Select/Set Knob until the desired value is displayed on the Temperature Readout.

HA		40	
----	---	----	---

Maximum Fluid Pressure (FP)

This is the maximum allowable fluid pressure and can be set in either PSI or kPa (the LED adjacent to the display indicates the active unit of measure). Should the fluid pressure rise above the maximum fluid pressure value, the audio and visual alarms will activate and the compressor, heater, fan, and pump will turn off.

To change the fluid pressure limit value, rotate the Select/Set Knob until the desired value is displayed on the Temperature Readout.

	NOTE: When FP first appears, the PSI LED will be lit. To view the FP value in kPa, press the Units/Menu Button again. The FP will remain on the display, and the kPa LED will light up.
---	--

FP	• PSI		80	
----	-------	---	----	---

FP	• kPa x 100		5.5	
----	-------------	---	-----	---

 **NOTE:** Chillers with positive displacement and turbine pumps also incorporate a built-in safety that automatically maintains fluid pressure below a valve-regulated pressure value. It maintains this maximum outlet pressure by diverting the flow of process fluid to the reservoir (i.e., begin internally recirculating the fluid). A maximum pressure value is set at the factory, but is user-adjustable. See “*Adjusting the High Pressure Bypass Setting*” for information on changing the maximum outlet pressure value.

Minimum Flow Rate (FL)

 **NOTE:** If flow rates are below 1.5 GPM (6 LPM), this feature is not recommended as nuisance alarms may result.

This is the minimum allowable flow rate and can be set in either GPM or LPM (the LED adjacent to the display indicates the active unit of measure). Should the fluid flow rate drop below the minimum value, the audio and visual alarms will activate, and the compressor, heater, fan, and pump will turn off.

To change the minimum flow rate value, rotate the Select/Set Knob until the desired flow rate value is displayed on the Temperature Readout.

With FL set to “0”, the flow alarm is disabled, and the Chiller will continue to operate with the output flow blocked.

 **NOTE:** When FL first appears, the GPM LED will be lit, indicating the FL value is GPM. To view the FL value in LPM, press the Units/Menu Button again. The FL will remain on the display and the LPM LED will light up.

FL	• GPM		0.2	
----	-------	---	-----	---



FL	• LPM		1.0	
----	-------	---	-----	---

Flow Rate Calibration (Fc)

 **NOTE:** Your Chiller’s flow rate is calibrated at the factory at the nominal flow value for the installed pump. Further adjustment is not necessary.

This menu item allows you to adjust the flow rate display to match that of a known standard.

1. Press and hold the Units/Menu Button until HL appears on the display.
2. Press and release the Units/Menu Button until the second FL appears (LPM LED will be lit – Fc will be the next parameter).
3. Press and hold the Units/Menu Button.
4. While holding the Units/Menu Button, press and release the Select/Set Knob.
5. When CAL appears on the Temperature Readout, release the Units/Menu Button.
6. Rotate the Select/Set Knob until the desired offset is displayed. Press the Select/Set Knob or simply allow the display to time out to accept the displayed value.

Fc		0.0	
----	---	-----	---

Auto-Refrigeration Temperature (AF)

	NOTE: This value is always displayed/set in °C.
---	--



This menu item allows you to select the temperature at which refrigeration is activated. When the set point exceeds the auto-refrigeration temperature by more than 1.0°C, the cooling and the fan are turned off.

To change the auto-refrigeration temperature, rotate the Select/Set Knob until the desired value is displayed.

AF		35	
----	---	----	---

Compressor Band (Cb)

This menu item allows you to set a temperature below set point at which the compressor will turn off. This protects the fluid temperature from dropping too low during periods of low or no heat load. The compressor will turn back on when the fluid temperature rises above set point.

Cb		-06	
----	---	-----	---

Calibration Offset (°1)

	IMPORTANT: To prevent the operator from accidentally changing the calibration offset, a special keystroke sequence is required to access this function.
---	--

This menu item allows you to adjust the Chiller's temperature reading to match that of a traceable standard. It allows you to offset the displayed temperature value by as much as ±1.9°C.

	NOTE: Calibration offset values are always set and displayed in °C.
---	--

1. Press and hold the Units/Menu Button until HL appears on the display.
2. Press and release the Units/Menu Button until AP appears on the display.
3. Press and hold the Units/Menu Button.
4. While holding the Units/Menu Button, press and release the Select/Set Knob.
5. When CAL appears on the Temperature Readout, release the Units/Menu Button. The current calibration offset value will appear on the Temperature Readout and alternate with the fluid temperature reading (allowing you to simultaneously adjust the offset and see the effect on the temperature reading).
6. Rotate the Select/Set Knob until the desired calibration offset is displayed. Press the Select/Set Knob or simply allow the display to time out to accept the displayed value.

°C		0.0	
----	---	-----	---

Baud Rate (PC)

This menu item allows you to establish the baud rate for serial communication. Allowable settings are 0 (no serial communication), 24 (2400 baud), 48 (4800 baud), 96 (9600 baud), and 192 (19200 baud).

To change the displayed setting, rotate the Select/Set Knob until the desired baud rate is displayed.

Press the Select/Set Knob or allow the display to time out to accept the displayed value.



Display, Alarm and Error Messages

When certain conditions are detected, a message code flashes on the display and the local audio alarm sounds. Depending on the nature of the condition, power to various systems components, such as the compressor, heater, fan, and pump, is removed. When the condition is rectified, push the front panel Power Button or turn the Power Switch OFF then ON to clear the fault or error.

Message Code	Description	Action Required
EFL	Low fluid level warning — units with fluid level float switch	Warning / Alarm — Fluid level float switch or flow switch is open. Alarm will sound once every 8 seconds for 5 occurrences. If problem has not been corrected after 40 seconds, Fault 05 occurs. Add fluid to the reservoir.
EHA	High ambient temperature warning (front panel)	Warning — The ambient temperature is higher than the set ambient limit. The display alternates between EHA and the fluid temperature; the unit continues normal operation. If this lasts more than 5 seconds, fault 16 occurs. Lower ambient temperature or raise high ambient temperature limit.
EHL	High temperature set point warning	Warning — The temperature set point is higher than the high temperature limit value. The display alternates between EHL and the fluid temperature. The unit continues normal operation. If the fluid temperature rises above the HL setting, Fault 03 is activated. Decrease heat load or increase the HL setting.
ELL	Low temperature limit alarm	Warning — The temperature set point is lower than the low temperature limit value. The display alternates between ELL and the fluid temperature; the unit continues normal operation. If the fluid temperature stays below the LL value for 25 seconds, Fault 02 occurs. Increase temperature set point or decrease low limit value.
LLO	Local Lockout	Normal — Indicates that Local Lockout feature (see <i>Enabling / Disabling the Local Lockout</i>) is enabled. Appears momentarily when Select/Set Knob is pressed to view/change set point value.
CAn	Cancel Local Lockout	Normal — Indicates the Local Lockout feature (see <i>Enabling / Disabling the Local Lockout</i>) has been disabled. Appears momentarily when Local Lockout status is changed from enabled (LLO) to disabled.
EC	External remote control active	Normal — Chiller is in Standby mode until remotely activated (optional).

If a fault should occur, the left display will show Ft, and the right display will show one of the fault codes shown below.



Fault Code	Description	Action Required
02	Low limit temperature alarm	Alarm — Process fluid temperature is below the low temperature limit value for more than 25 seconds. Compressor, heater, and fan are turned off; pump remains on. To clear the fault, turn the unit OFF then ON using the front panel Power Button, and decrease the LL value.
03	High limit temperature alarm	Alarm — Process fluid temperature is above the high temperature limit value for more than 25 seconds. Compressor, heater, and fan are turned off; pump remains on. To clear the fault, turn the unit OFF then ON using the front panel Power Button, and increase the HL value.
04	Over-temperature alarm	Alarm — Process fluid temperature is above Chiller's factory set high temperature safety cutoff. Heater, compressor, and fan turned off; pump remains on. Lower process temperature.
05	Low liquid level alarm (select models only)	Delayed Alarm — Activated when the liquid level in the reservoir falls below an acceptable level for over 40 seconds. Compressor, heater, fan, and pump are turned off. Add fluid to reservoir.
07	Low flow alarm	Alarm — Flow rate has dropped below minimum flow rate setting for more than 10 seconds. Compressor, heater, fan, and pump are turned off. Note: Disabled during first 2 minutes of operation. Correct cause of low flow rate or decrease minimum flow rate setting.
08	High pressure alarm	Alarm — Fluid outlet pressure has exceeded the high-pressure limit value for over 10 seconds. Compressor, heater, fan, and pump are turned off. Decrease outlet pressure by removing blockage or increase high-pressure limit value.
09	Internal software fault	Fault — One or more settings are out of range. Compressor, heater, fan, and pump are turned off. Default unit to °C or °F; if fault persists, contact service representative.
10	Electronic power component fault (Triac)	Fault — Heater triac has failed for more than 10 seconds. Compressor, heater, fan, and pump are turned off. Contact service representative.
11	Internal probe fault	Fault — Main temperature control probe has failed for more than 4 seconds. Compressor, heater, fan, and pump are turned off. Contact service representative.
12	External temperature probe fault (select models only)	Fault — External temperature control probe has failed for more than 4 seconds. Compressor, heater, fan, and pump are turned off. Replace external probe or operate instrument using internal temperature probe. Contact service representative if fault persists.
13	Communications fault	Fault — Internal electronics failure. Power to compressor, heater, fan, and pump are turned off. Contact service representative.
14	ADC fault, internal probe	Fault — ADC for internal probe faulty. Power to compressor, heater, fan, and pump are turned off. Contact service representative.
15	ADC fault, external probe	Fault — ADC for external probe faulty. Power to compressor, heater, fan, and pump are turned off. Contact service representative.

Fault Code	Description	Action Required
16	Front panel high ambient temperature alarm	<p>Alarm – Ambient temperature at front panel is higher than high ambient temperature limit. Occurs when ambient temperature exceeds the set ambient limit by 5°C or more. Compressor, heater, fan, and pump are turned off.</p> <p>Lower temperature in area where Chiller is located or increase high ambient temperature limit value.</p>

Enabling / Disabling the Local Lockout

This feature is used to prevent unauthorized or accidental changes to set point and other operational values. When enabled, the values for the following functions can be displayed, but not changed:

- Temperature unit
- Temperature set point
- Pressure / flow rate units

To enable the local lockout, press and hold the Select/Set Knob until LLO is displayed (approximately 5 seconds). Once enabled, LLO will appear momentarily when the Select/Set Knob is pressed to display the set point.

To disable the local lockout, press and hold the Select/Set Knob until CAn appears momentarily as local lockout status changes from enabled (LLO) to disabled (approximately 5 seconds).



IMPORTANT: The Local Lockout feature does not prevent set point changes entered via the RS232 interface.

Routine Maintenance and Troubleshooting

Routine Maintenance

The Chiller is designed to require a minimum of periodic maintenance.

Condenser, Air Vents and Reusable Filter

To keep the system operating at optimum cooling capacity, the condenser, the air vents, and reusable filter should be kept free of dust and dirt. They should be checked on a regular basis and cleaned as required.

The reusable filter is easily accessed from either the left or right side of the unit. Use a mild detergent and water solution to wash off any accumulated dust and dirt. Rinse and dry thoroughly before reinstalling.

Fluid Filter

A removable, highly efficient fluid filter is located downstream of the process fluid inlet. To access the filter for cleaning, remove the top of the Chiller (attached to the rear of the unit with three screws) and unscrew the large threaded filter cap. Pull the filter out of the fitting, rinse off accumulated particulate matter, and reinstall. Check for leaks after reinstalling.

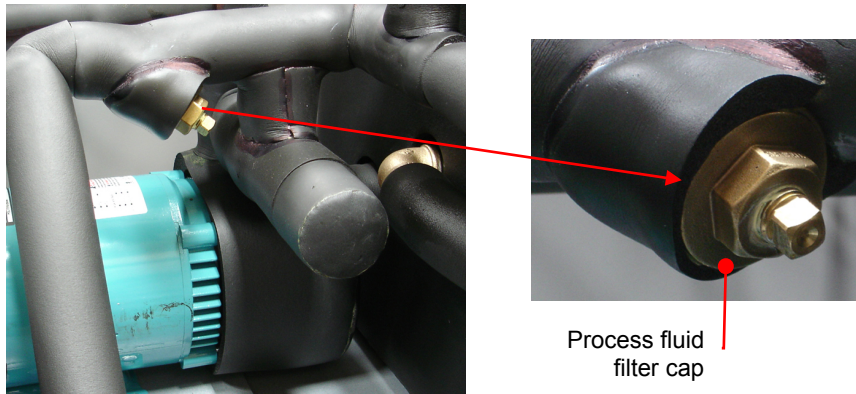

Fluid Level

The fluid level should be periodically checked to determine if the fluid level needs to be topped off. A sight glass viewing port is provided on the rear left side of the Chiller housing for this purpose. Generally, fluid should be added whenever the level in the reservoir is 2 inches (5.1 cm) below the top of the reservoir.



NOTE: On units equipped with the heater option, check fluid level when operating at maximum temperature and allow for fluid expansion. Use of a venting assembly is recommended.

Cleaning

Only mild detergents and water or an approved cleaner should be used on the painted and stainless steel surfaces of the Chiller. Do not allow cleaning liquids or sprays to enter the Controller vents.

Temperature Calibration

At times, there may be a minor temperature difference between the Chiller's displayed temperature and the actual temperature as determined by a certified temperature measurement device. There may also be situations where you want the displayed temperature to match a particular value to have standardization between different instruments. These adjustments can be performed using the Chiller's internal and/or external temperature calibration offset functions. See "*Setting Operational Parameters, Calibration Offset*".

Troubleshooting

	<p>Many problems can be resolved by restoring the factory defaults. If this solves the problem, be careful when restoring your operational settings in order not to repeat the problem.</p> <p>To restore the factory default settings:</p> <ol style="list-style-type: none"> 1. Place the Power Switch on the rear of the unit in the OFF position. 2. Press and hold the Power Button on the front panel while returning the Power Switch to the ON position.
---	--

	<p>WARNING: Service should only be performed by qualified personnel. Extreme caution is required as hazards are present when servicing this equipment.</p>
---	---

	<p>WARNING: When electrical power is ON, dangerous voltages exist within chassis components. Use extreme care when measuring voltages on live circuits.</p>
---	--

Problem	Possible Causes	Corrective Action
Unit does not run (digital displays blank)	No power to unit	Check that the electrical cord or wiring is secure and connected to an operating electrical source. Check that Power Switch on rear of unit is ON.
Unit does not run (three decimal points appear on Temperature Display, two decimal points on Pressure/Flow Rate Display)	Unit in Standby mode	Press Power Button on front panel.
No fluid circulation	Insufficient fluid in reservoir Blockage in circulating system Pump is not operating	Add fluid to reservoir. Remove blockage. Replace pump.
Insufficient circulation	Fluid viscosity too high External tubing diameter too small Restrictions in fluid lines Low line voltage	Replace with lower viscosity fluid. Replace with larger diameter tubing. Check and correct as required. Check and correct as required.
Unit does not cool or cooling is insufficient	Dust build up on air filter or condenser Blocked air ventilation screens Excessive heat load Ambient air temperature too high Low or high line voltage	Clean air filter and/or condenser as required. Remove blockages as required. Check that heat load does not exceed capacity of Chiller; correct as required. Decrease ambient air temperature. Check and correct as required.
Fault code 11 on display	Internal probe failure	Contact service representative.
Fault code 12 on display	Loose external probe connection Faulty external temperature probe	Check and correct as required. Replace as required. NOTE: Chiller may be operated using internal probe until problem is corrected.

Diagnostic Mode



NOTE: The Chiller must be set up to display temperature in °C in order to access the diagnostic mode.

The Chiller incorporates a Diagnostic mode, which displays important operational information that can aid in troubleshooting. To access the Diagnostic mode, place the Power Switch on the rear of the unit in the OFF position and then return it to the ON position while pressing and holding the Select/Set Knob. The diagnostic menu appears on the Pressure/Flow Rate Display; the current value for the diagnostic item appears on the Temperature Readout.



NOTE: Diagnostic items are display values only; they cannot be changed..

Menu Item	Description
At	Ambient temperature at front panel
EC	External control
Ut	Upper (head) temperature
Li	Percent of Line voltage
Ct	Chiller type (model)
Fb	Fuse bits (remote control voltage, contact closures, etc.)
03 (variable numeric value)	Fluid flow rate or pressure; Temperature Display shows current fluid temperature

Technical Information

Controller Specifications

Temperature Set Point Resolution	±1.0°C
Temperature Stability	±0.9°F (±0.5°C)
Temperature Units	°C or °F
Pressure Units	PSI or kPa
Pressure Display Resolution	1 PSI / 0.1 kPa
Flow Rate Units	GPM or LPM
Flow Rate Display Resolution	0.1 GPM / 1 LPM

Performance Specifications – DCA200 Chillers

		DCA200 Air-Cooled
Compressor	Nominal HP	2
Temperature Range (without heater option)	°F	41° to 95°F
	°C	5° to 35°C
Temperature Range (with heater option)	°F	41° to 194°F
	°C	5° to 90°C
Temperature Stability	°F	±0.9°F
	°C	±0.5°C
Cooling Capacity (60Hz units) ¹	Tons	1.99
	Watts	7000
	BTU/hour	23,885
Cooling Capacity (50Hz units) ¹	Tons	1.75
	Watts	6160
	BTU/hour	21,038
Nominal Evaporator Flow ²	US GPM	4.82
Refrigerant		R134A
Pressure	PSIG	7.5
Pump	HP	3/4
Fan(s)	HP	2 @ 1/6
Condenser Discharge Air Flow	CFM	1680
Water Condenser Flow – Tower Water	US GPM	N/A
Water Condenser Connections	Inches	N/A
Process Connections (inlet / outlet)	Inches	0.75
Reservoir Tank Capacity	US Gallons (liters)	7 (26.5)
Dimensions (L x W x H)	Inches	30.5 x 37 x 42
	cm	78 x 94 x 107
Shipping Weight	Pounds	520
	kg	236

1. Capacity based on 68°C (20°C) entering air and 68°F (20°C) leaving water.

2. Chiller flow rate based on 2.4 US GPM ton (0.54m³/hr/ton).

Electrical Specifications — DCA200 Chillers

2 HP AIR-COOLED	NO HEATER		3000 WATT HEATER		7500 WATT HEATER		9000 WATT HEATER			
	MAX. OPERATING AMPERAGE	FUSE / CIRCUIT BREAKER SIZE	MAX. OPERATING AMPERAGE	FUSE / CIRCUIT BREAKER SIZE	MAX. OPERATING AMPERAGE	FUSE / CIRCUIT BREAKER SIZE	MAX. OPERATING AMPERAGE	FUSE / CIRCUIT BREAKER SIZE		
DCA203D1/S1	21.9	35	34.4	45	NA					
DCA203D5/S5	20.5	35	33	45						
DCA203D6/S6	22.9	35	35.4	45						
DCA203D7/S7	21.4	35	33.9	45						
DCA203C4	17.8	30	30.3	40						
DCA203F	20.6	30	33.1	45						
DCA203G	Consult Factory									
DCA204D1/S1	18.8	30	26	40	36.8	50	40.5	55		
DCA204D2/S2	22.4	35	29.6	40	40.4	50	44.1	55		
DCA204D5/S5	16.2	25	23.4	35	34.2	50	37.9	50		
DCA204D6/S6	20.0	30	27.2	40	38	50	41.7	55		
DCA204D7S7	17.6	30	24.8	35	35.6	50	39.3	50		
DCA204C3	22.5	35	29.7	40	40.5	50	44.2	55		
DCA204C4	16.4	25	23.6	35	34.4	50	38.1	50		
DCA204F	16.8	30	24	35	34.8	50	38.5	50		
DCA204G	20.0	30	27.2	40	38	50	41.7	55		
DCA206D1/S1	9.5	15	13.1	20	NA					
DCA206D2/S2	11.4	17.5	15	20					20.3	30
DCA206D5/S5	8.3	15	11.9	20					22.2	30
DCA206D6/S6	10.1	15	13.7	20					19.1	30
DCA206D7S7	8.8	15	12.4	20					20.9	30
DCA206C3	10.5	15	14.1	20					19.6	30
DCA206C4	8.2	15	11.8	20					21.3	30
DCA206F	8.5	15	12.1	20					19	30
DCA206G	10.0	15	13.6	20					19.3	30
DCA208D1/S1	9.4	15	13	20					20.8	30
DCA208D2/S2	10.7	17.5	14.3	20					20.2	30
DCA208D5/S5	8.3	15	11.9	20					21.5	30
DCA208D6/S6	9.6	15	13.2	20					19.1	30
DCA208D7S7	8.5	15	12.1	20					20.4	30
DCA208C3	11.2	17.5	14.8	20					19.3	30
DCA208C4	8.4	15	12	20					22	30
DCA208F	8.6	15	12.2	20					19.2	30
DCA208G	10.1	15	13.7	20	19.4	30				
					20.9	30				

Environmental Conditions	Indoor use only
Maximum Altitude:	2000 meters
Operating Ambient:	5° to 35°C
Relative Humidity:	80% for temperatures to 30°C
Installation Category:	II
Pollution Degree:	2

Performance Specifications – DCA300 and DCW300 Chillers

3 HP		DCA300 Air-Cooled	DCW300 Water-Cooled
Compressor	Nominal HP	3	
Temperature Range (without heater option)	°F °C	41° to 95°F 5° to 35°C	
Temperature Range (with heater option)	°F °C	41° to 194°F 5° to 90°C	
Temperature Stability	°F °C	±0.9°F ±0.5°C	
Cooling Capacity (60Hz units) ¹	Tons	2.99	3.11
	Watts	10,500	10,936
	BTU/hour	35,859	37,348
Cooling Capacity (50Hz units) ¹	Tons	2.63	2.77
	Watts	9240	9624
	BTU/hour	31,556	32,868
Nominal Evaporator Flow ²	US GPM	6.92	7.46
Refrigerant		R134A	
Pressure	PSIG	14	
Pump	HP	3/4	
Fan(s)	HP	2 @ 1/6	N/A
Condenser Discharge Air Flow	CFM	2170	N/A
Water Condenser Flow – Tower Water	US GPM	N/A	9.33 (20-40 psi / 1.4-2.8 bar)
Water Condenser Connections	Inches	N/A	0.75
Process Connections (inlet / outlet)	Inches	0.75	
Reservoir Tank Capacity	US Gallons (liters)	7 (26.5)	
Dimensions (L x W x H)	Inches cm	30.5 x 37 x 42 78 x 94 x 107	
Shipping Weight	Pounds	570	
	kg	259	

1. Capacity of air-cooled units based on 68°C (20°C) entering air and 68°F (20°C) leaving water; capacity of water-cooled units based on 85°F (29°C) entering water.

2. Chiller flow rate based on 2.4 US GPM ton (0.54m³/hr/ton).

Electrical Specifications — DCA300 & DCW300 Chillers

3 HP AIR-COOLED	NO HEATER		3000 WATT HEATER		7500 WATT HEATER		9000 WATT HEATER			
	MAX. OPERATING AMPERAGE	FUSE / CIRCUIT BREAKER SIZE	MAX. OPERATING AMPERAGE	FUSE / CIRCUIT BREAKER SIZE	MAX. OPERATING AMPERAGE	FUSE / CIRCUIT BREAKER SIZE	MAX. OPERATING AMPERAGE	FUSE / CIRCUIT BREAKER SIZE		
DCA303D1/S1	39.6	60	52.1	80	NA					
DCA303D5/S5	38.2	60	50.7	80						
DCA303D6/S6	40.6	60	53.1	80						
DCA303D7/S7	39.1	60	51.6	80						
DCA303C4	35.5	60	48	75						
DCA303F	38.3	60	50.8	80						
DCA303G	Consult Factory									
DCA304D1/S1	27.8	45	35	50	45.8	70	49.5	70		
DCA304D2/S2	31.4	45	38.6	60	49.4	70	53.1	70		
DCA304D5/S5	25.2	40	32.4	50	43.2	70	46.9	70		
DCA304D6/S6	29	45	36.2	60	47	70	50.7	70		
DCA304D7S7	26.6	40	33.8	50	44.6	70	48.3	70		
DCA304C3	31.5	50	38.7	60	49.5	70	53.2	70		
DCA304C4	25.4	40	32.6	50	43.4	70	47.1	70		
DCA304F	25.8	40	33	50	43.8	70	47.5	70		
DCA304G	29	45	36.2	60	47	70	50.7	70		
DCA306D1/S1	12.8	20	16.4	25	NA					
DCA306D2/S2	14.7	20	18.3	30					23.6	35
DCA306D5/S5	11.6	20	15.2	25					25.5	35
DCA306D6/S6	13.4	20	17	25					22.4	35
DCA306D7S7	12.1	20	15.7	25					24.2	35
DCA306C3	13.8	20	17.4	25					22.9	35
DCA306C4	11.5	20	15.1	25					24.6	35
DCA306F	11.8	20	15.4	25					22.3	35
DCA306G	13.3	20	16.9	30					22.6	35
DCA308D1/S1	12.7	20	16.3	25					24.1	35
DCA308D2/S2	14	20	17.6	30					23.5	35
DCA308D5/S5	11.6	20	15.2	25					24.8	35
DCA308D6/S6	12.9	20	16.5	25					22.4	35
DCA308D7S7	11.8	20	15.4	25					23.7	35
DCA308C3	14.5	25	18.1	30					22.6	35
DCA308C4	11.7	20	15.3	25					25.3	35
DCA308F	11.9	20	15.5	25					22.5	35
DCA308G	13.4	20	17	25	22.7	35				
					24.2	35				

3 HP WATER-COOLED	NO HEATER		3000 WATT HEATER		7500 WATT HEATER		9000 WATT HEATER	
	MAX. OPERATING AMPERAGE	FUSE / CIRCUIT BREAKER SIZE	MAX. OPERATING AMPERAGE	FUSE / CIRCUIT BREAKER SIZE	MAX. OPERATING AMPERAGE	FUSE / CIRCUIT BREAKER SIZE	MAX. OPERATING AMPERAGE	FUSE / CIRCUIT BREAKER SIZE
DCW304D1/S1	27.8	45	35	60	45.8	70	49.5	70
DCW304D2/S2	31.4	50	38.6	60	49.4	70	53.1	75
DCW304D5/S5	25.2	40	32.4	50	43.2	70	46.9	70
DCW304D6/S6	29	45	36.2	60	47	70	50.7	70
DCW304D7/S7	26.6	40	33.8	50	44.6	70	48.3	70
DCW304C3	31.5	50	38.7	60	49.5	70	53.2	70
DCW304C4	25.4	40	32.6	50	43.4	70	47.1	70
DCW304F	25.8	40	33	50	43.8	70	47.5	70
DCW304G	29	45	36.2	60	47	70	50.7	70
DCW306D1/S1	12.8	20	16.4	25	NA		23.6	35
DCW306D2/S2	14.7	25	18.3	30			25.5	35
DCW306D5/S5	11.6	20	15.2	25			22.4	35
DCW306D6/S6	13.4	20	17	25			24.2	35
DCW306D7/S7	12.1	20	15.7	25			22.9	35
DCW306C3	13.8	20	17.4	25			24.6	35
DCW306C4	11.4	20	15.1	25			22.3	35
DCW306F	11.8	20	15.4	25			22.6	35
DCW306G	13.3	20	16.9	25			24.1	35
DCW308D1/S1	12.7	20	16.3	25			23.5	35
DCW308D2/S2	14	20	17.6	30			24.8	35
DCW308D5/S5	11.6	20	15.2	25			22.4	35
DCW308D6/S6	12.9	20	16.5	25			23.7	35
DCW308D7/S7	11.8	20	15.4	25			22.6	35
DCW308C3	14.5	20	18.1	30			25.3	35
DCW308C4	11.7	20	15.3	25			22.5	35
DCW308F	11.9	20	15.5	25			22.7	35
DCW308G	13.4	20	17	30			24.2	35

Environmental Conditions Indoor use only
Maximum Altitude: 2000 meters
Operating Ambient: 5° to 35°C
Relative Humidity: 80% for temperatures to 30°C
Installation Category: II
Pollution Degree: 2

Pump Performance

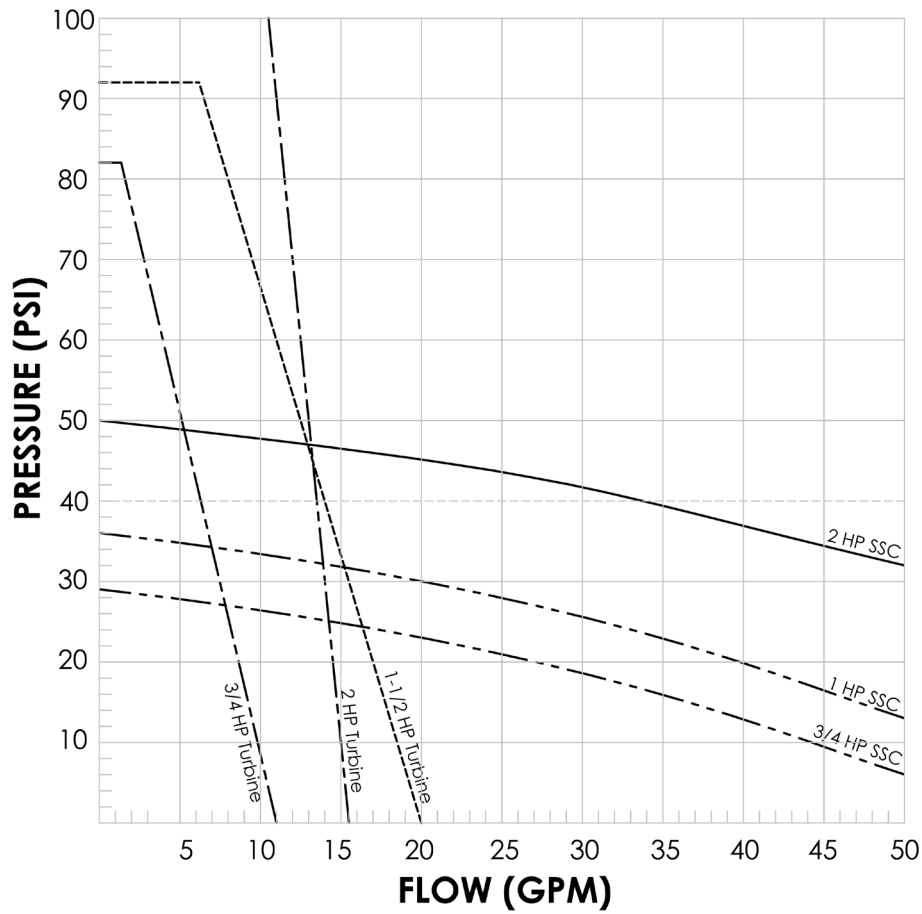

CHILLERS NOMINAL DESIGN FLOWS

2 HP 4.82 GPM
3 HP 6.92 GPM

Pumps					230 Volt Single Phase	208-230V / 380-460V 50/60 Hz 3 Phase
	Size	Pump Model	2 HP DCA200	3 HP DCA300 / DCW300	Part Numbers	
Stainless Steel Centrifugal Pumps	3/4 HP	C4	<input checked="" type="checkbox"/>	<input checked="" type="checkbox"/>	215-742	215-740
	1 HP	F	<input checked="" type="checkbox"/>	<input checked="" type="checkbox"/>	215-735	215-733
	2 HP	G	<input checked="" type="checkbox"/>	<input checked="" type="checkbox"/>	215-737	215-678
Bronze Turbine Pumps	3/4 HP	D5	<input checked="" type="checkbox"/>	<input checked="" type="checkbox"/>	215-499	215-487
	1.5 HP	D1	<input checked="" type="checkbox"/>	<input checked="" type="checkbox"/>	215-534	215-483
	2 HP	D6	<input checked="" type="checkbox"/>	<input checked="" type="checkbox"/>	215-336	215-354
Stainless Steel Turbine Pumps	3/4 HP	S5	<input checked="" type="checkbox"/>	<input checked="" type="checkbox"/>	215-474	215-475
	1.5 HP	S1	<input checked="" type="checkbox"/>	<input checked="" type="checkbox"/>	215-808	215-536

Specifications subject to change without notice.

RS-232 / RS-485 Communications

Serial Connector — A 9-pin D-connector (optional) is provided on the back panel of the Chiller for RS232 / RS485 data communication. A serial cable that uses only the following pins should be used to connect the Chiller to the computer:

RS-232	
Pin # 2	data read (data from computer)
Pin # 3	data transmit (data to computer)
Pin # 5	signal ground

RS-485	
Pin # 3	DAT (+) on "B"
Pin # 5	signal ground
Pin # 9	DAT (-) on "A"

RS-232 / RS-485 Protocol — The controller uses the following RS-232 / RS-485 protocol:

- Data bits — 8
- Parity — none
- Stop bits — 1
- Flow control — none
- Baud rate — selectable (Chiller and PC baud rates must match).

Communications Commands — Commands must be entered in the exact format shown. Do not send a [LF] (line feed) after the [CR] (carriage return). Be sure to follow character case exactly. A question mark (?) indicates that the Chiller could not execute the command (either because it was in an improper format or the values were outside the allowable range). A response followed by an exclamation point (!) indicates that a command was executed correctly. A response must be received from the Chiller before another command can be sent. All responses are terminated with a single [CR].

Command Description	Command Format	Values	Return Message
Set command echo	SEi[CR]	Echo: i = 1 No Echo: i = 0	![CR]
Set on / off	SOi[CR]	On: i = 1 Off: i = 0	![CR]
Set set point	SSxxx[CR]	x = ASCII digit	![CR]
Read set point temperature	RS[CR]		![CR]
Read temperature	RT[CR]		![CR]
Read temperature units	RU[CR]	C or F	C[CR] or F[CR]
Read status	RW[CR]	1 = Run 0 = Standby	1[CR] or 0[CR]
Read pressure in PSI	RP[CR]		![CR]
Read pressure in kPa	RK[CR]		![CR]
Read flow in GPM	RG[CR]		![CR]
Read flow in LPM	RL[CR]		![CR]
Read remote control voltage	RC[CR]		![CR]
Read discharge point of compressor temperature in °C	RH[CR]		![CR]
Read remote temperature probe	RR[CR]		![CR]
Read ambient temperature on PCB	RA[CR]		![CR]

Equipment Disposal (WEEE Directive)

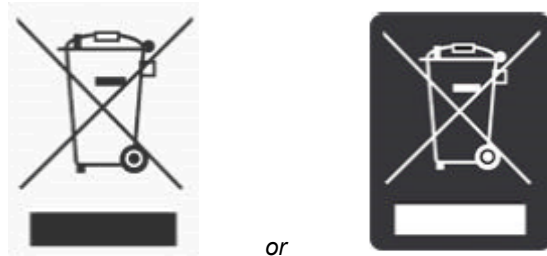

This equipment is marked with the crossed out wheeled bin symbol to indicate it is covered by the Waste Electrical and Electronic Equipment (WEEE) Directive and is not to be disposed of as unsorted municipal waste. **Any products marked with this symbol must be collected separately, according to the regulatory guidelines in your area.**

It is your responsibility to correctly dispose of this equipment at lifecycle-end by handing it over to an authorized facility for separate collection and recycling. It is also your responsibility to decontaminate the equipment in case of biological, chemical and/or radiological contamination, so as to protect the persons involved in the disposal and recycling of the equipment from health hazards. By doing so, you will help to conserve natural and environmental resources and you will ensure that your equipment is recycled in a manner that protects human health.

Requirements for waste collection, reuse, recycling, and recovery programs vary by regulatory authority at your location. Contact your local responsible body (e.g., your laboratory manager) or authorized representative for information regarding applicable disposal regulations.

Service and Technical Support

If you have followed the troubleshooting steps and your Recirculating Chiller fails to operate properly, contact the supplier from whom the unit was purchased. Have the following information available for the customer service person:

- Model, Serial Number, and Voltage (from back panel)
- Date of purchase and your purchase order number
- Suppliers' order number or invoice number
- A summary of your problem

PolyScience Chiller Fluids

Circulating Bath Fluids	Quantity	Part Number
polyclean Algaecide	8 oz / 236 ml	004-300040
polyclean Algaecide	Twelve 8 oz / 236 ml bottles	004-300041
polycool EG -25 (ethylene glycol)	1 gal / 4.5 liter	060340
polycool PG -20 (propylene glycol)	1 gal / 4.5 liter	060320
polycool HC -50 (water-based heat transfer fluid)	1 gal / 4.5 liter	060330
polycool MIX -25 (50/50 blend polycool EG -25 / H ₂ O plus polyclean algaecide)	Five 0.5 gal / 2.27 liter bottles	004-300060

Warranty



NOTE: The Warranty on DuraChill and other custom-designed products applies only to the original end user and cannot be transferred or sold to another end user without written consent from the manufacturer.

The manufacturer's warranty is one year for parts and labor and two years for parts. Please contact your supplier for additional warranty details and service contract information.

The manufacturer agrees to correct for the original user of this product, either by repair, or at the manufacturer's election, by replacement, any defect that develops after delivery of this product for the warranty period(s) stated above. In the event of replacement, the replacement unit will be warranted for 90 days or warranted for the remainder of the original unit's parts or labor warranty period, whichever is longer. If a replacement unit is sent, the defective unit must be returned to the manufacturer within 30 days of receipt of the replacement unit. If the defective unit is not received within 30 days, the manufacturer reserves the right to bill for the replacement unit.

If this product requires service, contact the manufacturer/supplier's office for instructions. If return of the product is necessary, a return authorization number will be assigned and the product should be shipped, (transportation charges pre-paid), to the indicated service center. To insure prompt handling, the return authorization number should be placed on the outside of the package and a detailed explanation of the defect enclosed with the item.

This warranty shall not apply if the defect or malfunction was caused by accident, neglect, unreasonable use, improper service, or other causes not arising out of defects in material or workmanship. There are no warranties, expressed or implied, including, but not limited to, those of merchantability or fitness for a particular purpose which extends beyond the description and period set forth herein.

The manufacturer's sole obligation under this warranty is limited to the repair or replacement of a defective product and shall not, in any event, be liable for any incidental or consequential damages of any kind resulting from use or possession of this product. Some states do not allow: (A) limitations on how long an implied warranty lasts; or (B) the exclusion or limitation of incidental or consequential damages, so the above limitations or exclusions may not apply to you. This warranty gives you specific legal rights. You may have other rights that vary from state to state.

Appendix

Flow Diagram – Air-Cooled Chillers

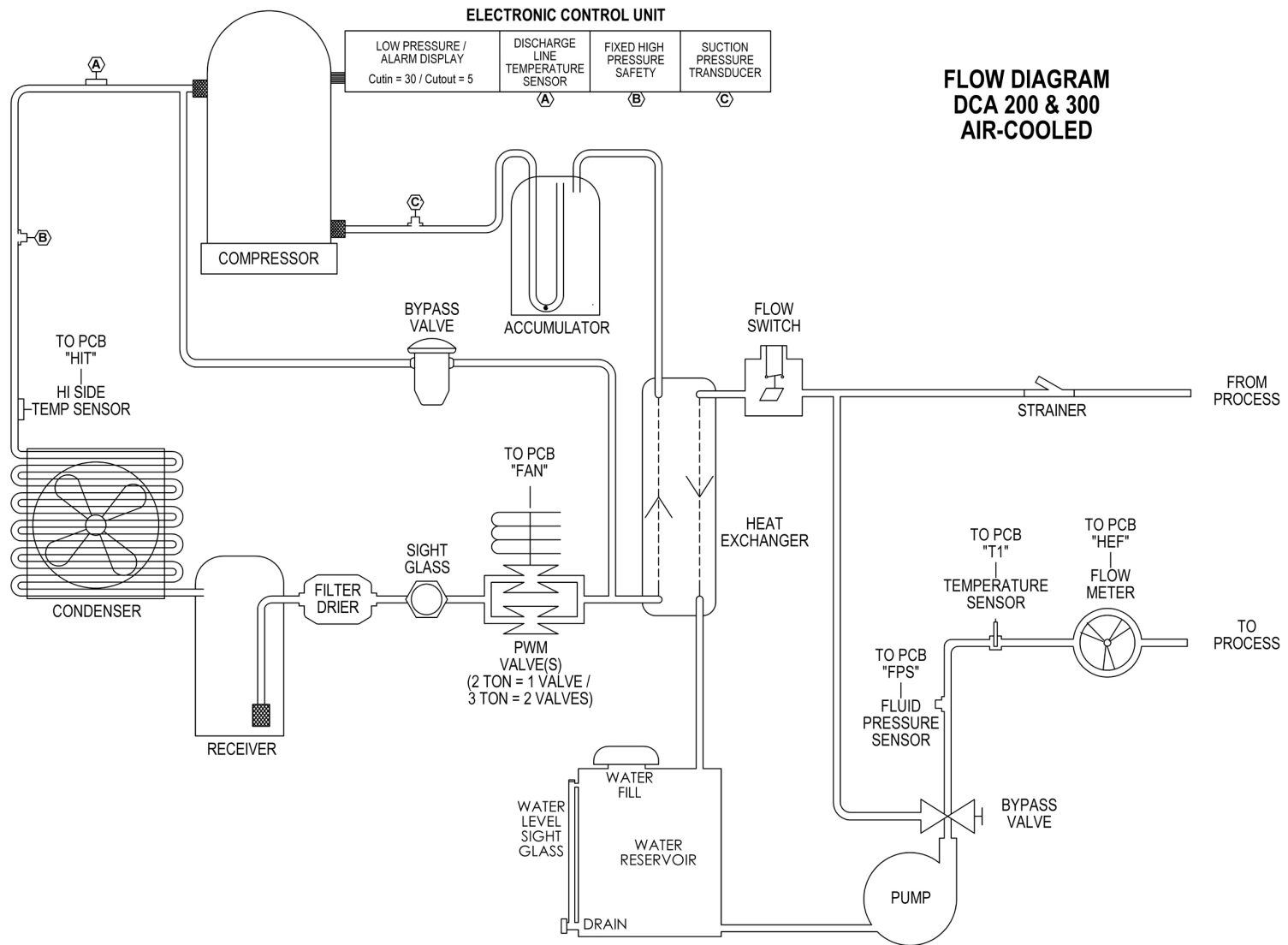

Flow Diagram – Water-Cooled Chillers

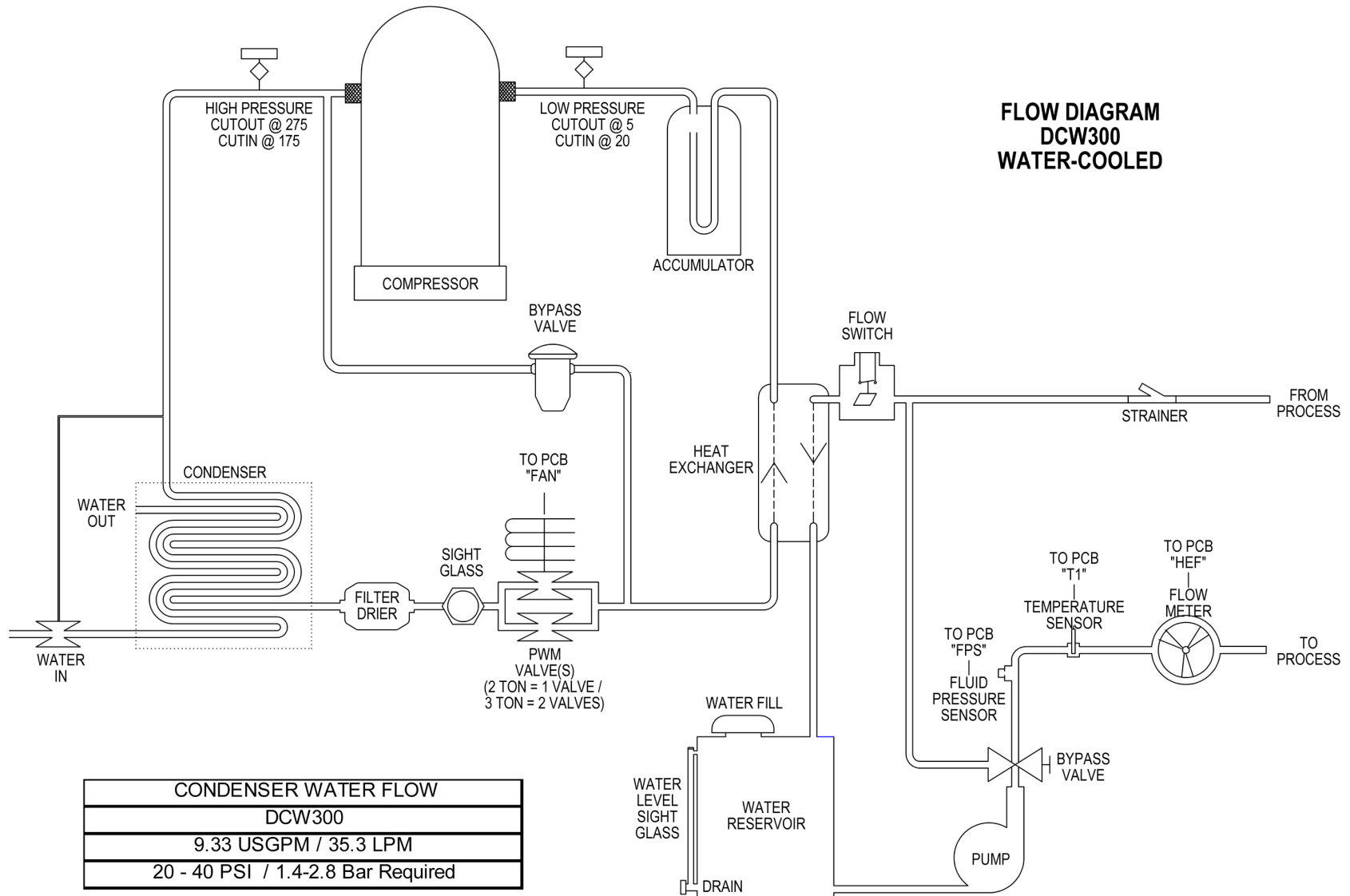

Wiring Diagram – 208-230V, 1 Phase Air-Cooled Chillers

208-230V SINGLE PHASE AIR-COOLED

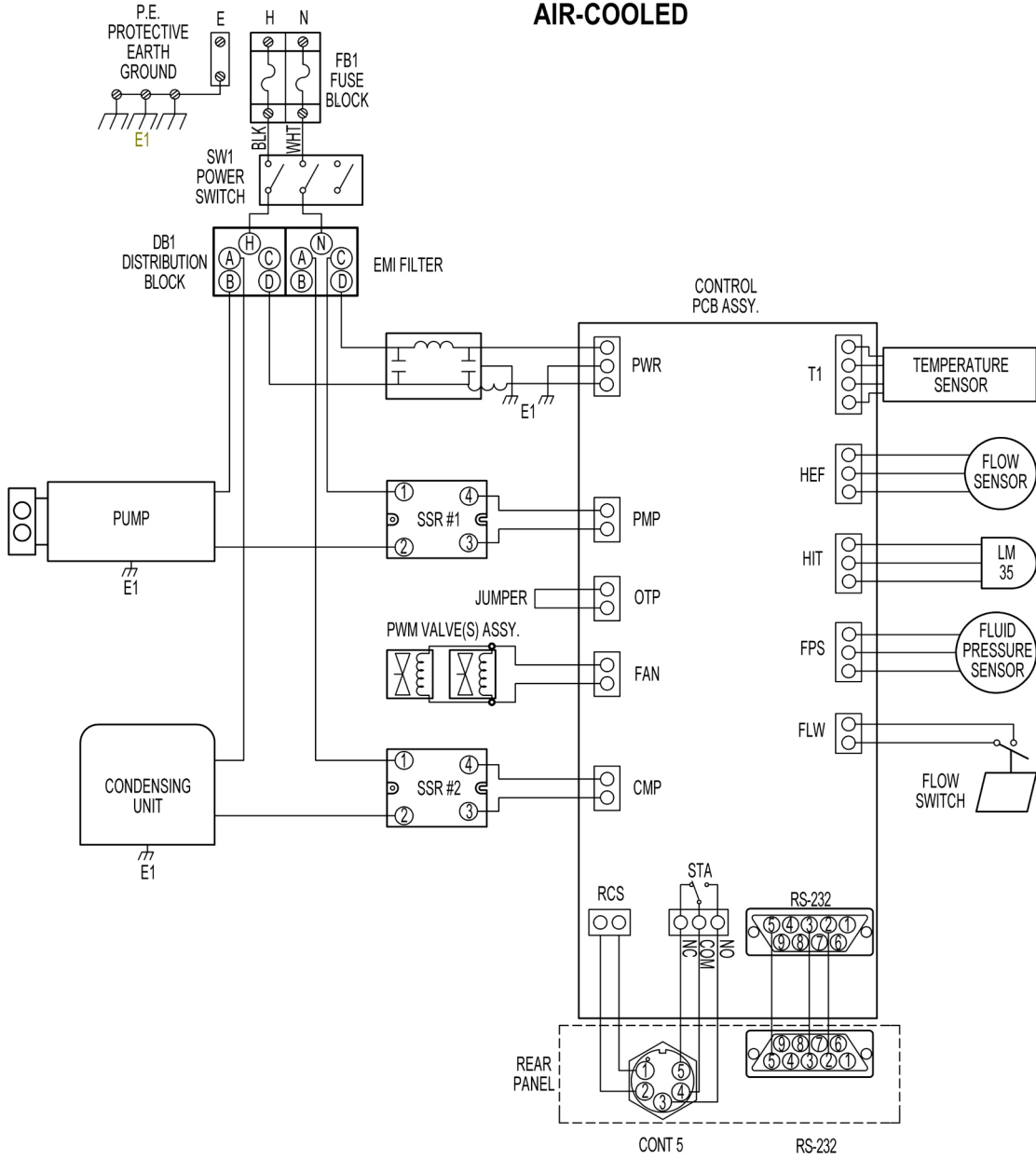

Wiring Diagram – 208-230V, 380-460V 3 Phase Air- and Water-Cooled Chillers

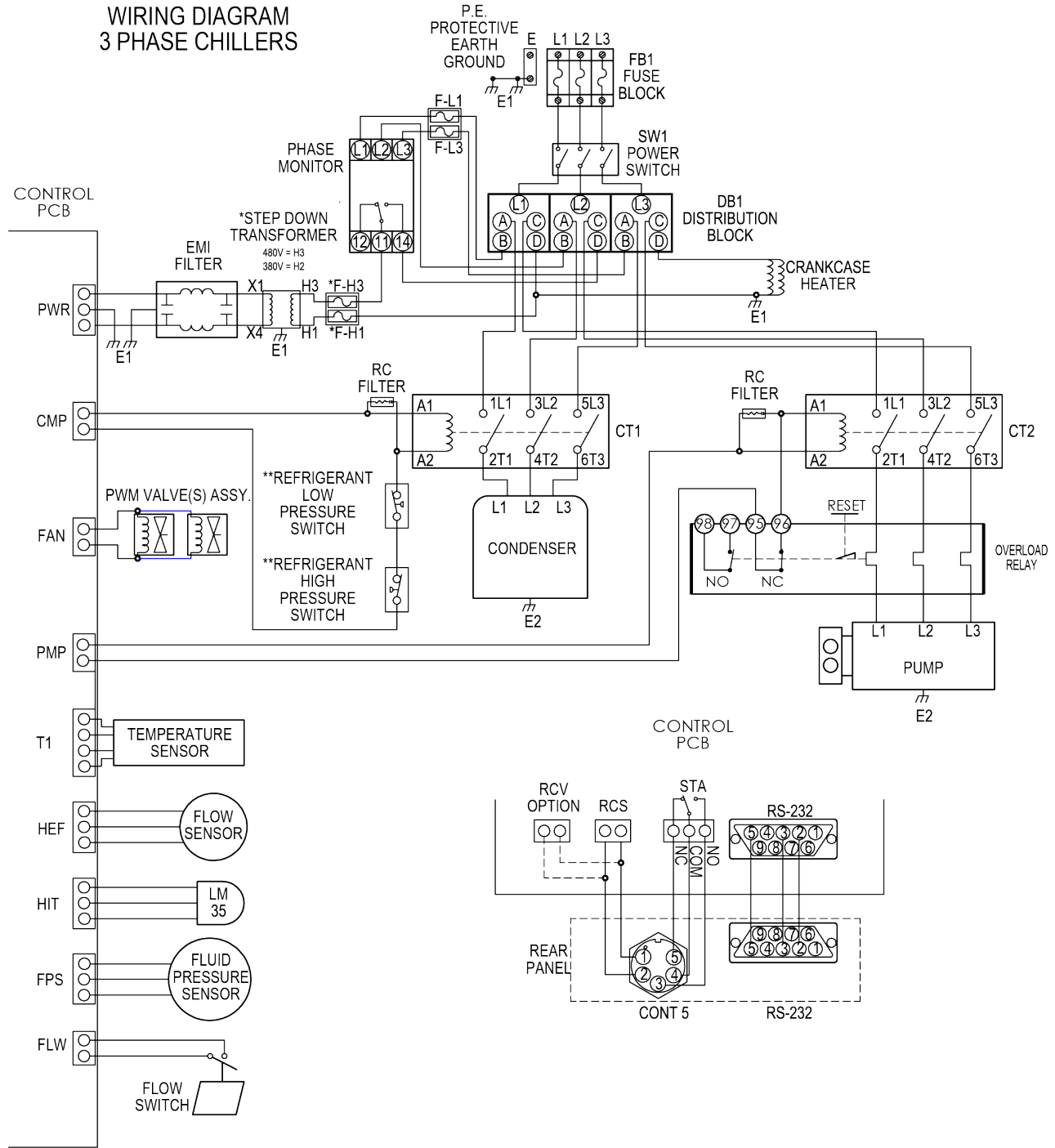

* STEP DOWN TRANSFORMER & PRIMARY FUSES ONLY ON 380V & 460V 3 PHASE UNITS ONLY.

**LOW AND HIGH REFRIGERANT PRESSURE SWITCHES SHOWN ARE FOR WATER-COOLED CHILLERS ONLY.

(NOTE: ALL AIR-COOLED CONDENSER UNITS HAVE AN ELECTRONIC CONTROLLER WITH PRESSURE & TEMPERATURE SENSORS.)