

AC POWER SOURCE

Variable Frequency Power System

AFC SERIES

Product Manual

If you meet any problem, you should seek immediate assistance from branches of Preen that the equipment was purchased or customer service & support department of Preen.

Preen pursues policy of continual product development and reserves the right to change the equipment design without notice.

This product manual was issued at August, 2007.

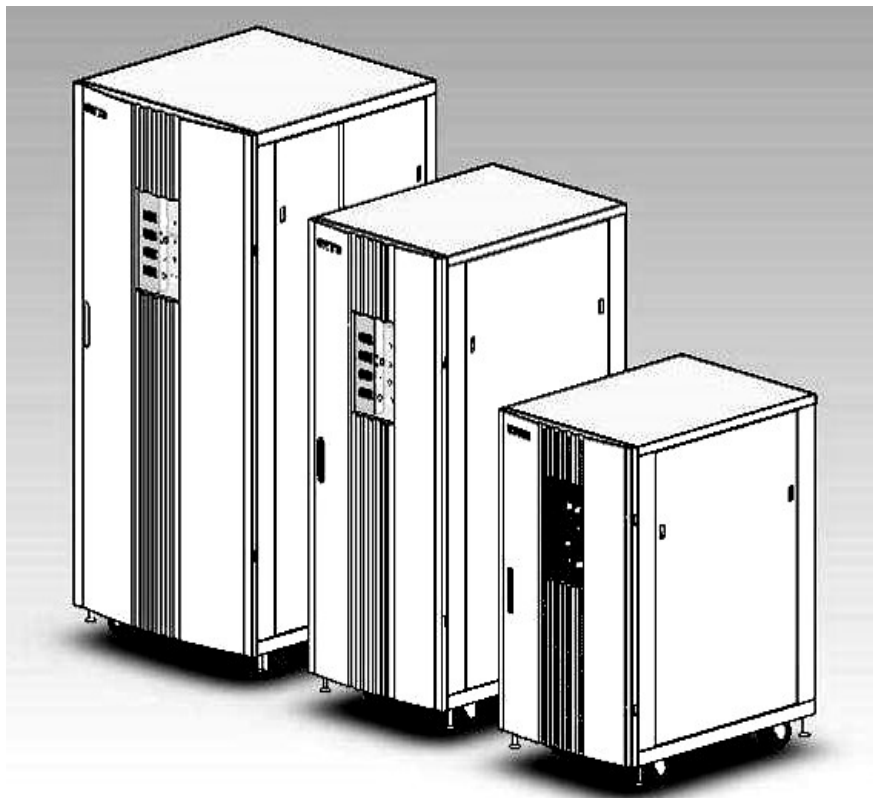

Copyright by Preen

All rights reserved.

Safety Notice

1. High voltage is in equipments. If the person does not belong to Preen or is not authorized by Preen, he is refused to open the cover, or he will be at the risk of electric shock.
2. When variable frequency power supply needs to be moved or rewired, input should be broken, and the power supply is completely shut down for 10 minutes; otherwise internal capacitors may still have electricity, so it is dangerous to get electric shock.
3. To protect users' safety, this series power supply must have good grounding protection. Before use it should be reliable grounding.
4. The environment and preservation method affect life and reliability of the power supply. Therefore, the product should be avoided long-term working in the following environment:
 - High, low and damp places beyond provisions of technical parameters (temperature: 0°C~45°C, relative humidity: 0%~90%);
 - Direct sunlight or near heat source sites;
 - Vibrating and vulnerable sites;
 - Places with dust, corrosive materials, salt and flammable gas.
5. Keep vent clean. If not, the inter temperature of the power supply will rise, then shorten components life, and affect the equipment life.
6. Liquid or other objects are not allowed to enter the power supply cabinet.
7. In case of fire break out, use the dry powder fire extinguishers. Use of liquid fire extinguishers will cause electric shock.
8. If not use for a long time, the variable frequency power supply must be stored in dry condition. Standard storage temperature range: -40°C~+70°C.

Index

Chapter 1 Product Intruduction	1
1.1 Why use it?	1
1.2 Static variable frequency power source introduction.....	1
1.3 Classification	1
1.4 Feature	1
Chapter 2 Working Principle and Structure of AFC Series	2
2.1 PWM control technology.....	2
2.2 PWM calculation and modulating method	3
2.3 AFC series variable frequency power supply work principle.....	5
2.4 System function frame	6
2.5 Specification	7
2.6 Front panel.....	8
2.7 Operation Part Instruction.....	11
2.8 Structure and Size	13
Chapter 3 Installation.....	15
3.1 Unpacking and Inspection	15
3.2 Installation Procedure	15
3.2.1 Installation notice.....	15
3.2.2 Installation step	16
Chapter 4 Operation.....	20
4.1 Operation mode	20
4.1.1 AC power inversion mode	20
4.1.2 Fault mode	20
4.2 Normal operation	20
4.2.1 Systme initial start	20
4.2.2 Normal operation	21
4.2.3 Out of power and shut down.....	22
Chapter 5 Maintenance	23
5.1 Maintenance notice.....	23
5.2 Fan	23
5.3 System inspection by eyes	23
5.4 Quarterly maintenance.....	24
5.5 Yearly maintenance	25
Chapter 6 Troubleshooting	26
Appendix Guarantee Card.....	28

Chapter 1 Product Introduction

1.1 Why use it?

Because the utility around the world are different, the exported electrical products need that the power supply stimulate the power system in different countries, the imported also need the power supply transferred the voltage and frequency in our country to ensure the normal operation. In the past, to achieve the above objective, generators have been used. But low efficiency, noise, cost, poor stability, and a certain degree of environment pollution, the generator is gradually replaced by a static variable frequency power source.

1.2 Static variable frequency power source introduction

Static variable frequency power supply contrast to the power source named from the motor-driven generator operation mode. With the rapid development of the electronic technology in the world and the large-scale application of high-power semiconductor switching devices, the static variable frequency power source has gradually become the main product in the market. It has gone through from mechanical to electronic transformation. With the rapid development of the global industry, variable frequency power supply applications are increasingly widespread.

1.3 Classification

At present, variable frequency power supply on the market can be divided into three kinds from the principles. One of them is under the control of sinusoidal pulse width modulation, and use IGBT devices, which was characterized by power, high efficiency (greater than 90%), small size, good stability. It has become the mainstream in the market; the second is a linear amplification as a variable frequency power source, which was characterized by small-power, high precision, small interference in some of the higher accuracy occasion. It is no substitute product. The third is to use resonant transformer to have a certain frequency and voltage as the power supply, but its frequency be fixed and adjustment difficulty, poor stability, be subject to interference, so its application has been limited in the market.

1.4 Feature

AFC series, the same as the other series variable frequency power supply, transfer the voltage and frequency of the utility to another through the power conversion circuit. It is one series of products which have adapted laminated bus bar technology, been redesigned control system, and realized the modular configuration. We not only simplify the production process and reduce the production costs, but also improve reliability. The features include:

- Capacity: 0.5kVA~2000kVA;
- Input power factor>0.85;
- Adapt laminated bus bar technology, reduce the inductance of the inverter circuit, and improve reliability;
- Individual air channel;
- Reliable control
- Full and steady protection;
- Judge and display error;
- Humanized design.

Chapter 2 Working Principle and Structure of AFC Series

2.1 PWM control technology

The four parts of AFC series variable frequency power supply: input, rectifier, inverter and output. Inverter is core technology in the four parts. Taking into account the complexity of the control algorithms and control circuit, PWM control technology will be described in detail.

PWM (Pulse Width Modulation) control - Pulse width modulation technology is a control method that equally gets required waveform (including shape and amplitude) by modulating serial pulse width. PWM control technology is widely used in inverter circuit.

Theoretical basis of PWM control – When narrow pulse with same impulse (impulse is area of narrow pulse) and different shape plus to inertial tache, the effects are basically same (the output response waveform basically the same to low frequency, only little difference in high frequency). As shown in Figure 2-1.

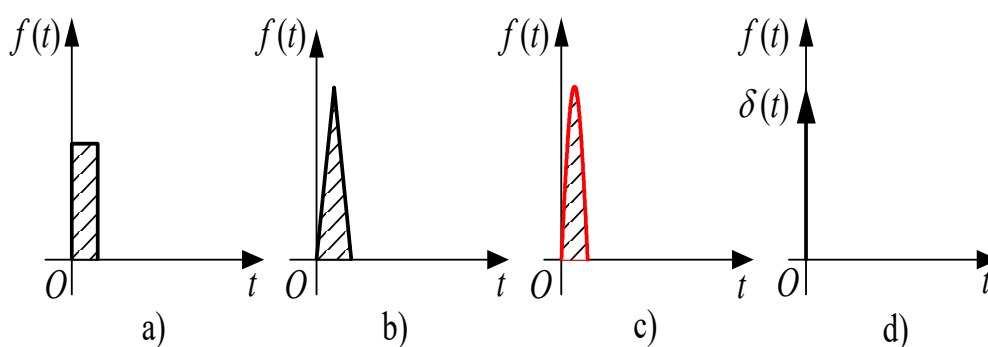

Figure 2-1 various narrow pulse with different shape and same impulse

Using series pulse with same amplitude and different width to replace a half sine wave--- this half sine wave is divided into N with same width and different amplitude, and is instead by rectangular pulse with same amplitude and different width. The midpoints are coincidence, the area (impulse) is equal, and the width changes according to sine rule. PWM waveform is that, pulse width changes according to sine rule and the waveform is equal to sine wave. The amplitude of sine waveform will change by modulating pulse width in proportion. As shown in Figure 2-2.

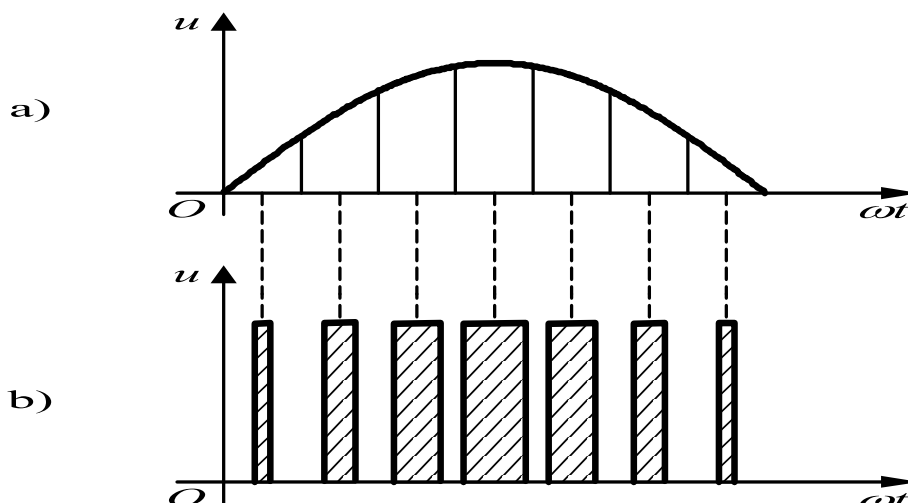

Figure 2-2 PWM wave brings sine wave

PWM wave is equal to sine wave---PWM wave is instead of sine wave according to the equivalent area principle. PWM wave with same amplitude can be easily generated by DC power, so currently most inverter circuits of medium and small power are used PWM technology. Inverter circuit is PWM control technology typical application. PWM inverter circuit can be divided into voltage and current type, but practical almost PWM inverter circuit is voltage circuit.

2.2 PWM calculation and modulating method

Illustrate for modulation method combining with IGBT single-phase bridge inverter circuit of voltage type (shown in Figure 2-3). At work, V1 and V2 alternant on-off, V3 and V4 also do. In U_o positive half cycle, V1 on and V2 off, V3 and V4 alternant on-off. Load current lag than voltage, and the positive and negative alternate for some time. When Load current is in positive range with V1 and V4 on, $U_o=U_d$. If V4 off, load current continued flow through V1 and VD3, $U_o=0$. When Load current is negative with V1 and V4 still on, I_o is negative. In fact I_o flow from VD1 and VD4, still $U_o=U_d$. If V4 off and V3 on, I_o continued flow from V3 and VD1, $U_o=0$. U_o can get two levels of U_d and zero. In U_o negative half cycle, V2 on and V1 off, V3 and V4 alternant on-off, so U_o can get two levels of $-U_d$ and zero.

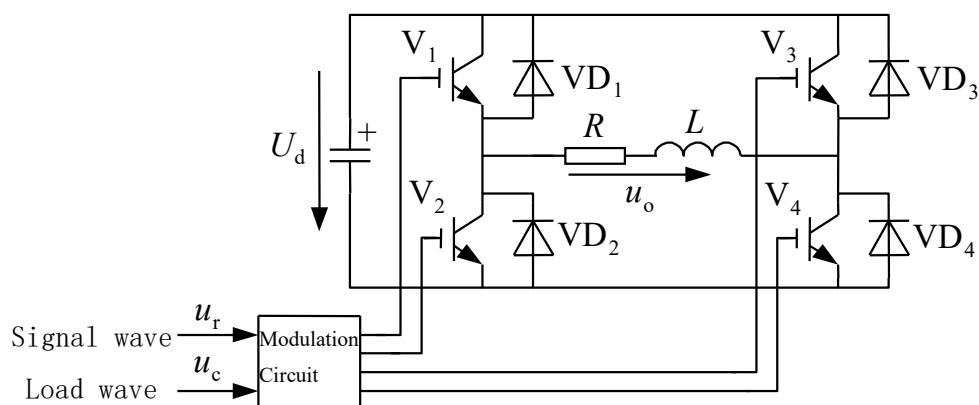

Figure 2-3 single phase bridge type PWM inverter circuit

Unipolar PWM control mode (single-phase bridge inverter): Control on-off of IGBT at u_r and u_c intersection.

In U_r positive half cycle, V_1 on and V_2 off. When $u_r > u_c$, V_4 on and V_3 off, $u_o = U_d$. When $u_r < u_c$, V_4 off and V_3 on, $u_o = 0$.

In U_r negative half cycle, V_1 off and V_2 on. When $u_r < u_c$, V_3 on and V_4 off, $u_o = -U_d$. When $u_r > u_c$, V_3 off and V_4 on, $u_o = 0$. The broken line u_{of} is fundamental component.

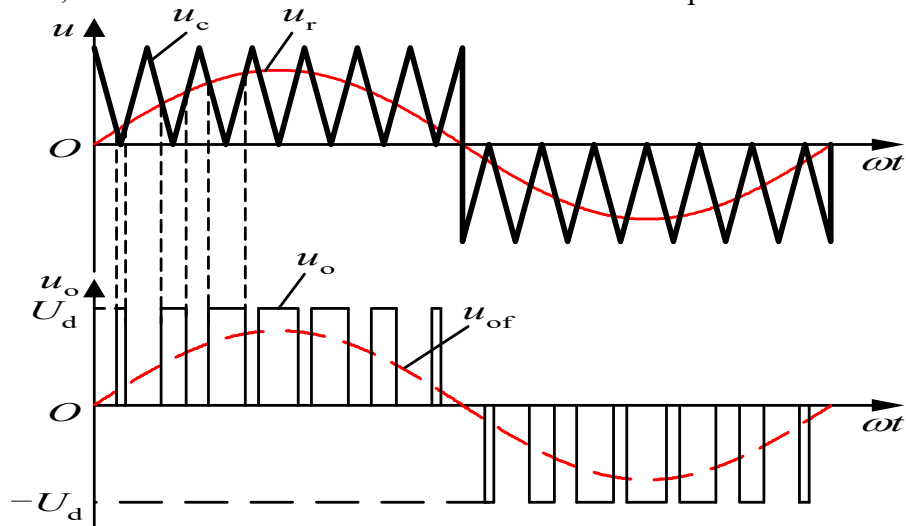

Figure 2-4 unipolar PWM control mode wave

2.3 AFC series variable frequency power supply work principle

AFC series variable frequency power control system mainly include six units: signal unit, PWM wave unit, feedback control unit, display unit, logic control unit, and protection unit. Every cell includes circuit function module.

Signal unit includes:

- Base frequency circuit
- Sine wave circuit

PWM wave unit includes:

- Triangle wave circuit
- PWM wave synthetical circuit

Feedback control unit includes:

- Voltage negative feedback circuit

Display unit includes:

- Voltage, frequency, current, power display circuit

Logic control unit includes:

- Soft start circuit
- Fault disposal circuit
- RESET circuit

Protection unit includes:

- Over load checking circuit
- Over voltage checking circuit
- Over temperature checking circuit
- Over current checking circuit
- Fuse checking circuit

2.4 System function frame

According to function frame from input to output, AFC series variable frequency control system can be divided into 23 function cells. (Shown in figure 2-5)

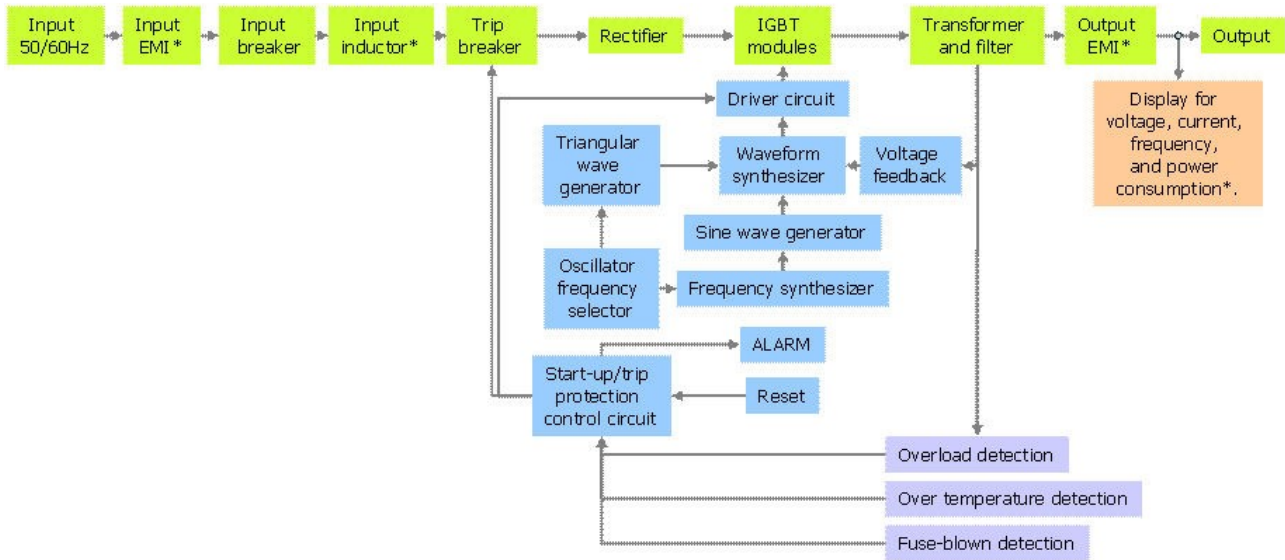

Figure 2-5 AFC series function frame

<Note> The AFC-500W is transistor amplifier type. The circuit and principle are different from IGBT circuit and system frame.

<Note2> This user manual only covers up to 200kVA. For higher kVA AFC series products, this manual does not cover. Please consult factory for above 200kVA user manual.

2.5 Specification

Model	AFC-_____
Circuit type	IGBT Pulse Width Modulation Type (Only 0.5kVA and 1kVA Transistor Amplifier Type)
Output capacity	<input type="checkbox"/> 0.5kVA <input type="checkbox"/> 3kVA <input type="checkbox"/> 5kVA <input type="checkbox"/> 10kVA <input type="checkbox"/> 15kVA <input type="checkbox"/> 30kVA <input type="checkbox"/> 45kVA <input type="checkbox"/> 60kVA <input type="checkbox"/> 80kVA <input type="checkbox"/> 100kVA <input type="checkbox"/> 120kVA <input type="checkbox"/> 160kVA <input type="checkbox"/> 200kVA
Input voltage	_____ phase _____ wire _____ V $\pm 15\%$ <input type="checkbox"/> Other _____
Input frequency	<input type="checkbox"/> 47Hz~63Hz <input type="checkbox"/> Other _____
Output voltage	<input type="checkbox"/> 5V~300V continuously adjustable <input type="checkbox"/> HI/LO changeable: (HI) 10~300V, (LO) 5V~150V <input type="checkbox"/> Standard setting voltage $+10\% \sim +25\%$, $-10\% \sim -30\%$ can pre-set <input type="checkbox"/> Other _____
Output frequency	<input type="checkbox"/> Adjustable frequency : 47~63Hz <input type="checkbox"/> Adjustable frequency : 45~500Hz <input type="checkbox"/> Fixed frequency: 50 / 60Hz <input type="checkbox"/> Fixed frequency: 50/60/2F/4F/400Hz <input type="checkbox"/> Fixed frequency: 400Hz <input type="checkbox"/> Other _____
Load regulation	<input type="checkbox"/> $\leq 1\%$ <input type="checkbox"/> _____
Frequency stability	<input type="checkbox"/> $\leq 0.01\%$ <input type="checkbox"/> _____
Wave	Standard sine wave
Total harmonic distortion	<input type="checkbox"/> $\leq 2\%$ (linear load) <input type="checkbox"/> _____
Efficiency	$\geq 90\%$ (with full load)
Protection	Over-load, short circuit, over-current, over-temperature, input under-voltage, lack of input phase protection, etc.
Panel display	Voltage meter: Res <input type="checkbox"/> 0.1V <input type="checkbox"/> _____ Current meter: Res <input type="checkbox"/> 0.01A <input type="checkbox"/> 0.1A <input type="checkbox"/> _____ Frequency meter: Res <input type="checkbox"/> 0.1Hz <input type="checkbox"/> _____ Power meter: Res <input type="checkbox"/> 0.001kW <input type="checkbox"/> 0.01kW <input type="checkbox"/> 0.1kW <input type="checkbox"/> 1kW <input type="checkbox"/> _____
Output/input connection mode	<input type="checkbox"/> Terminal row <input type="checkbox"/> Other _____
Ambient temperature	Working temperature: $0^{\circ}\text{C} \sim 45^{\circ}\text{C}$ Relative Humidity: $0 \sim 90\%$ (non-condensing)
Altitude	<1500m

2.6 Front panel

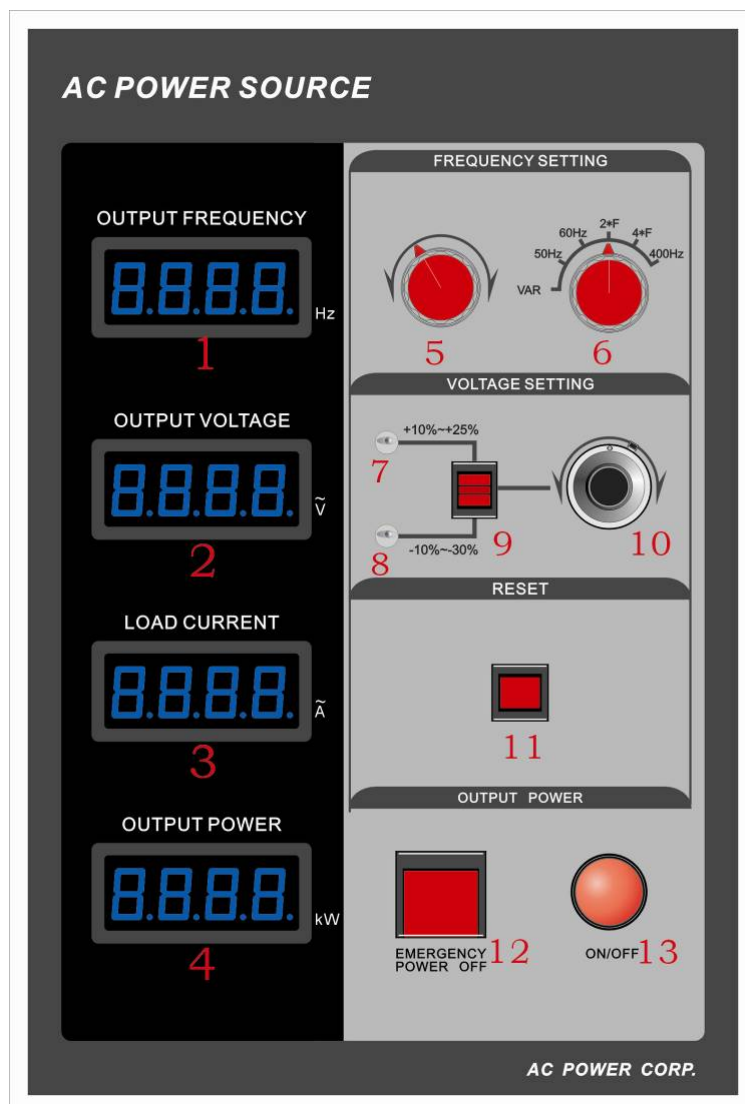
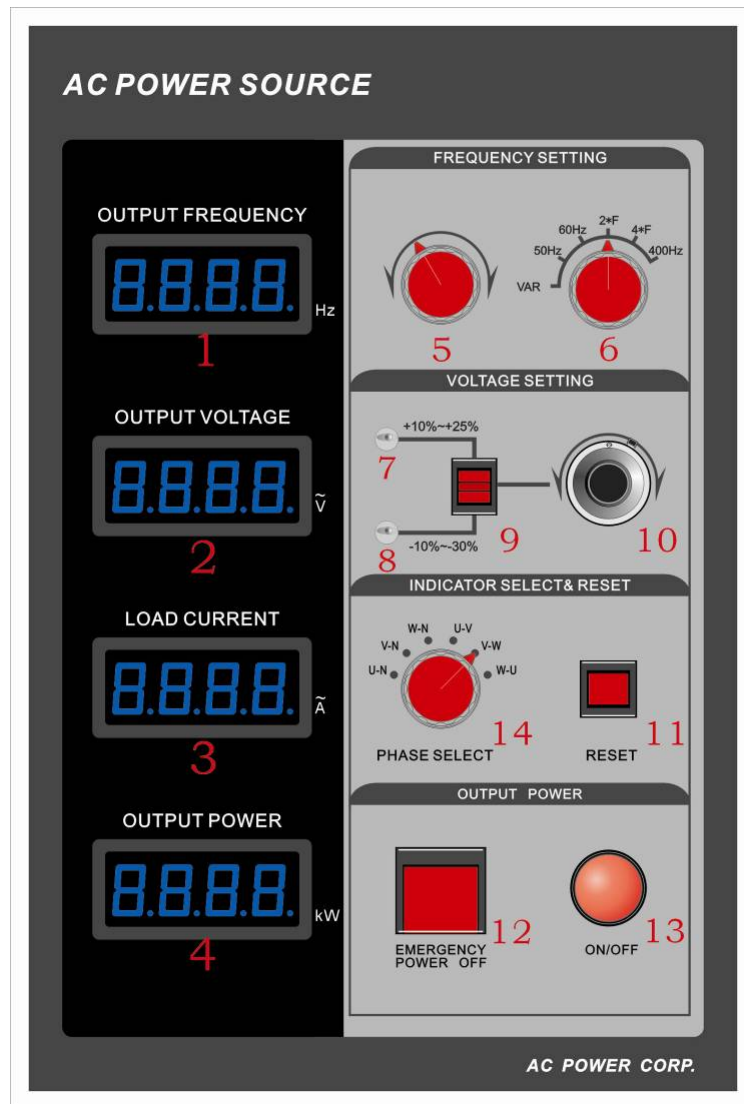

Figure 2-6 panel of AFC single-phase



(a) 6-75kVA series

THREE PHASE FRONT PANEL

IGBT TYPE

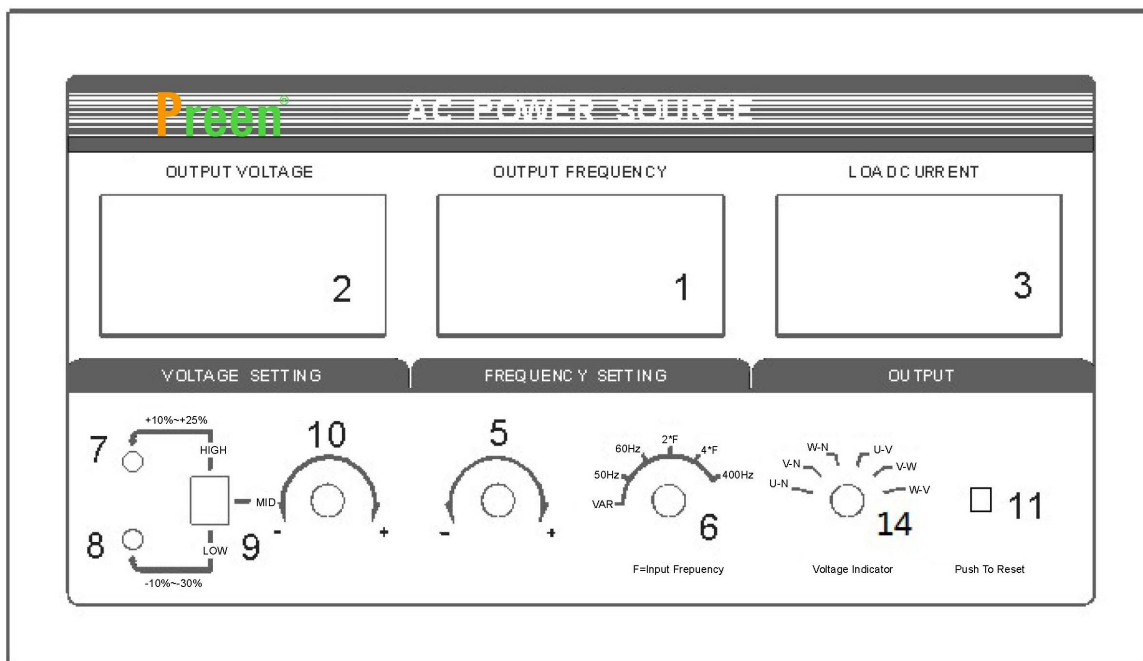

(b) 100-200kVA series

Figure 2-7 panel of AFC three-phase

- [1] — Output frequency display.
- [2] — Output voltage display.
- [3] — Output current display.
- [4] — Output power display.
- [5] — Adjustable frequency knob: Fine tuning for VAL (within default 47-63Hz or based on ordered factory option).
- [6] — Frequency band switch: For selecting output frequency band including: VAL(default 47-63Hz or based on ordered factory option), 50Hz, 60Hz, and optional: 2F, 4F, 400Hz.
- [7] — High-voltage range: output voltage be +10% ~ +25% higher than set.
- [8] — Low-voltage range: output voltage be -10% ~ -30% lower than set.
- [9] — 3 voltage selection switch: High: Set output voltage at range High.
Middle: General mode.
Low: Set output voltage at range LOW.
- [10] — Output voltage adjusting knob: adjust output voltage continuously.
- [11] — RESET key: Soft-start when turn on the machine or re-start after fault protection.
- [12] — Emergency power off button: For emergency shutdown.
- [13] — On/Off button: For output on or off.

「14」 —Phase select button: Select a phase for its reading in L-N or L-L.

2.7 Operation instruction

「1」 —Input breaker.

「2」 —Input terminal block.

「3」 —Output terminal block.

「4」 —HI/LO selecting switch: Press 「HI」 then output voltage 10V~300V; and press 「LO」 then output voltage 5V~150V. The output current in 「LO」 is double than 「HI」 .

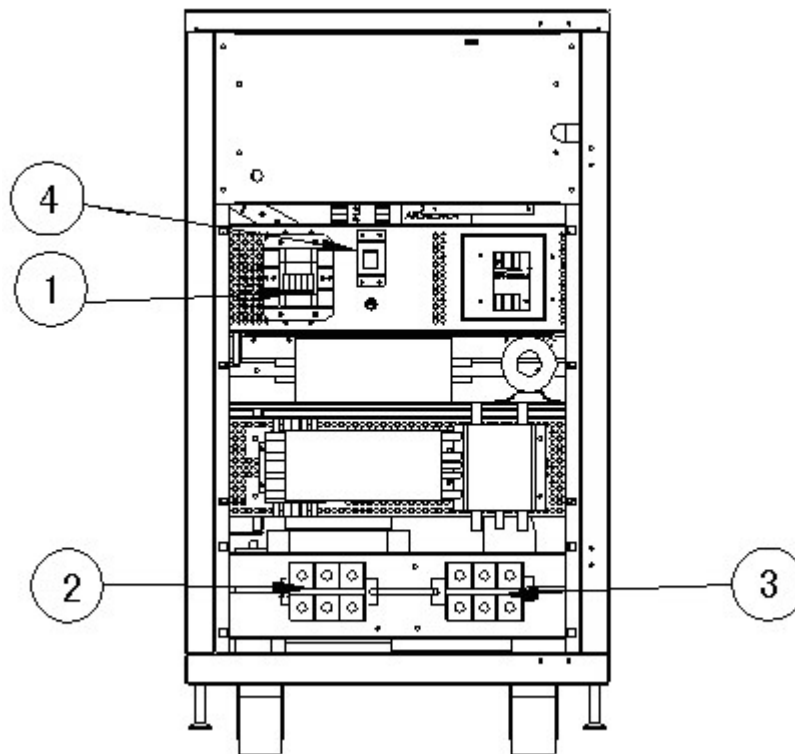

(a) AFC-11XXX series

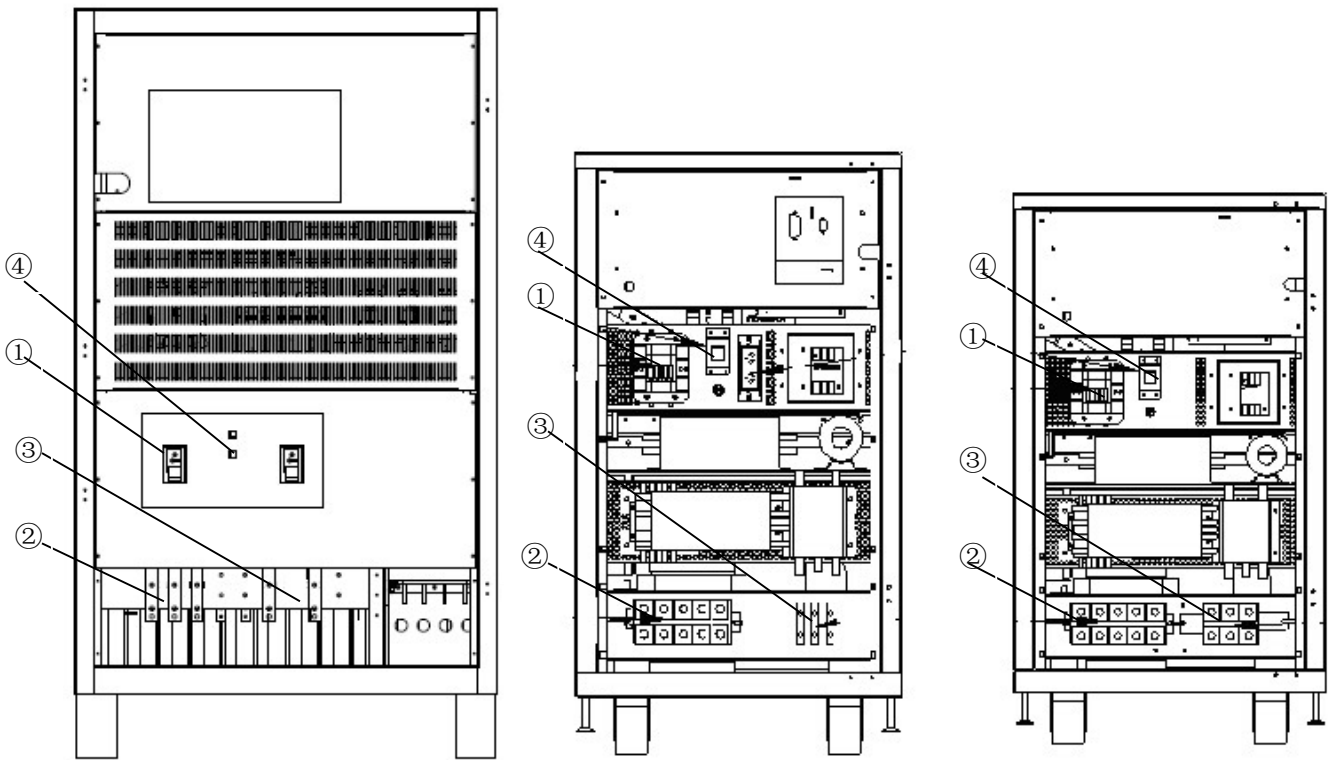

(b) AFC-31XXX series

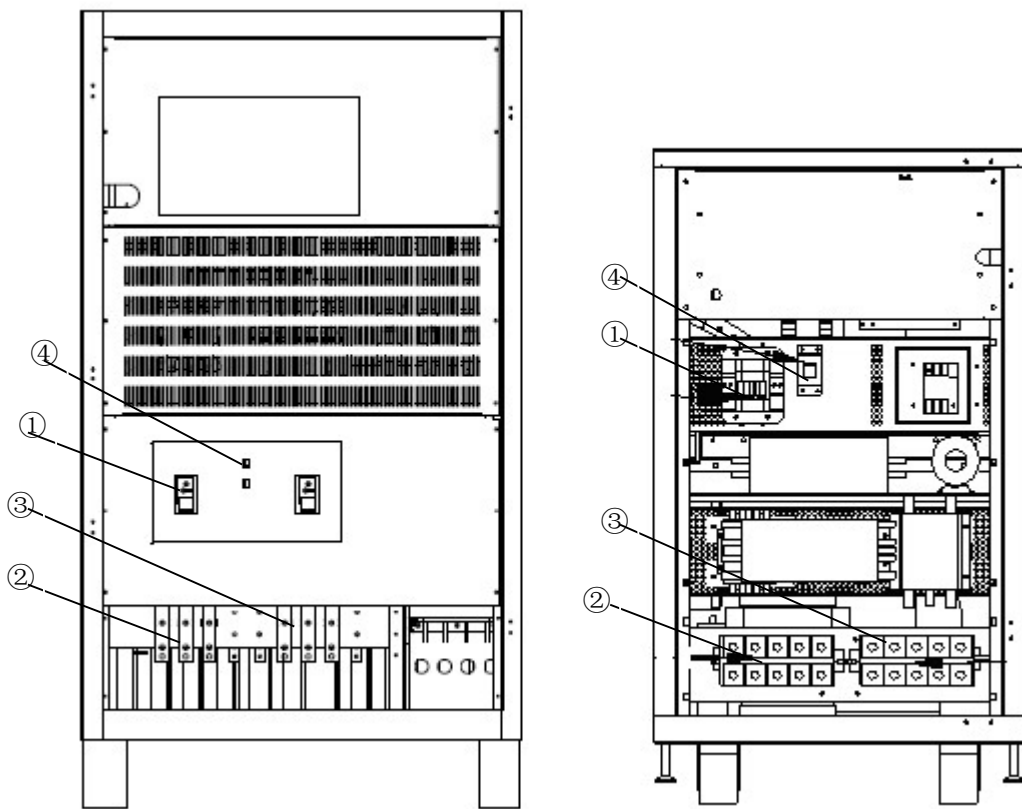

(c) AFC-33XXX series

Figure 2-8 operation part sketch

2.8 Structure and size

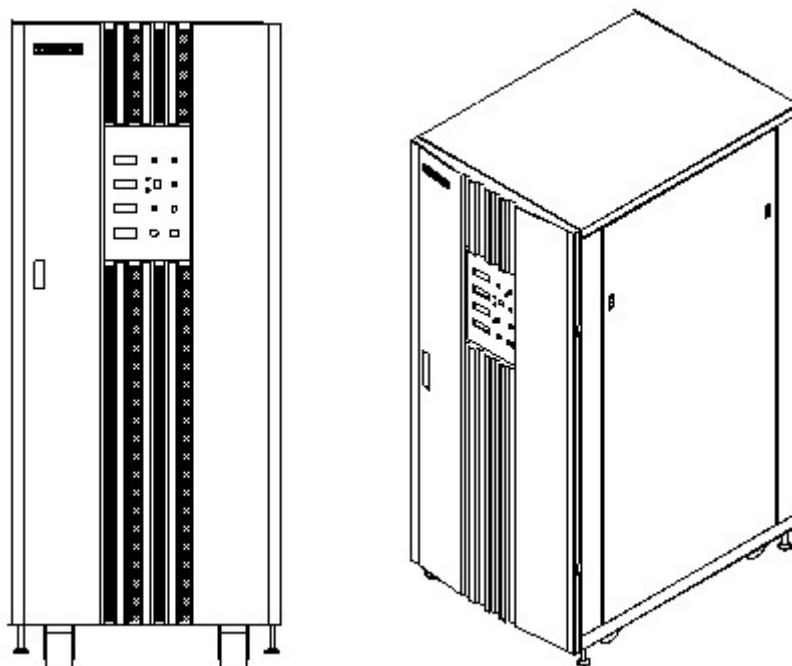

(a) 6-80kVA series

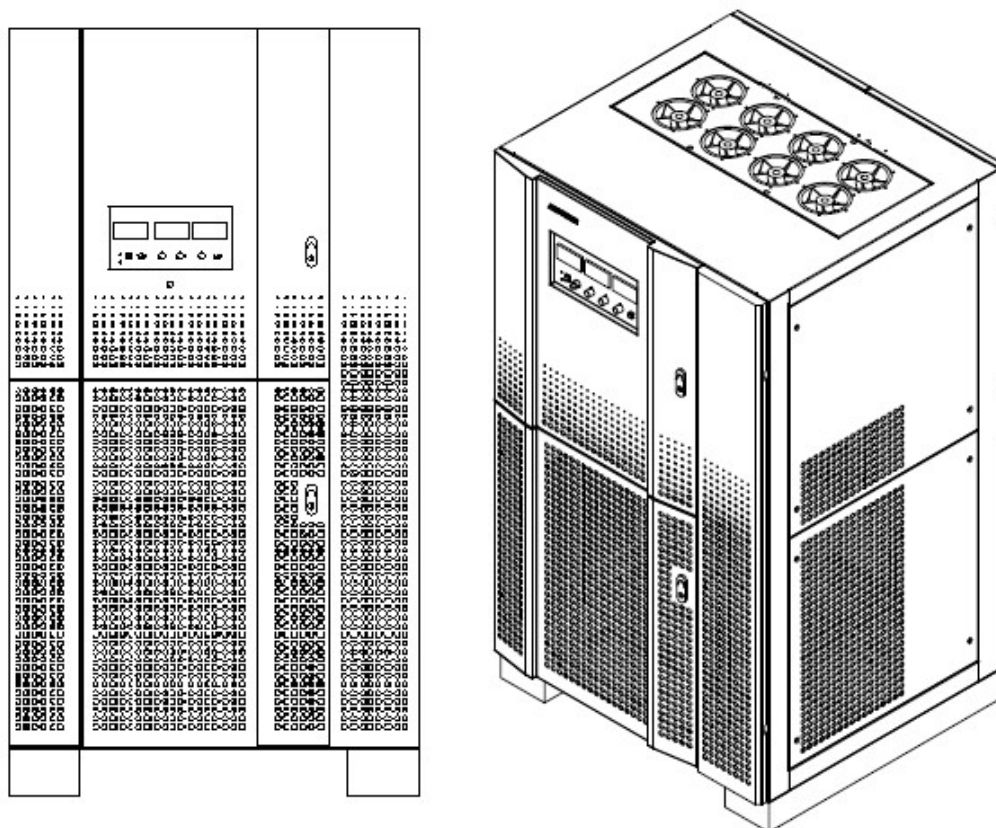

(a) 100-200kVA series

Figure 2-9 structure and size drawing of AFC series

Cabinet size table of AFC series:

Machine model	Size		
	W(mm)	D (mm)	H (mm)
AFC-500W	430	520	200
AFC-11003/11005	430	520	720
AFC-11010 AFC-31010/ AFC-33005	600	850	945
AFC-11015/11030 AFC-31015/31030 AFC-33010/33015/33030	600	850	1340
AFC-31045/31060 AFC-33045/33060	800	860	1545
AFC-31080 AFC-33080/33100	1050	970	1800
AFC-31100/31120 AFC-33120/33160/33200	1150	1240	1900

Chapter 3 Installation

3.1 Unpacking and inspection

- (1). Open the wooden box, bubble and bubble bags with variable frequency power supply in them. The equipment is too heavy, so it should be particularly careful to avoid falling or dumping when removes the equipment.
- (2). Inspect whether the equipment collision and damage during transport. If finding defective, do not turn on the machine and contact with distributors.
- (3). Examine random annex according to shipment annex list. If lack of any, please contact with distributors.

3.2 Installation procedure

3.2.1 Installation notice

- (1). Don't put the variable frequency power supply on uneven or gradient place to avoid abnormal operation.
- (2). Keep the distance from back of the machine to other equipments above 80cm; keep the distance from back of the machine to the wall at least 10cm; and put the variable frequency power supply near ventilation hole to prevent the inverter overheating and damage.
- (3). Avoid putting the inverter in sunlight, rain, or wet place.
- (4). Avoid placing the inverter in the place where contains corrosive gas.
- (5). Don't put out of doors.
- (6). Use correct power distribution mode, to guarantee safety of variable frequency power supply and user's equipments.

3.2.2 Installation step

(1). According to different models of variable frequency power supply, use correct input and output cables. Referring to tables 3-1 and 3-2.

Table 3-1 Input power distribution cable table

(a) Input high voltage

Input: 220V,230V,240V,277V						
Model (Standard)	Input current (A)	Input live line (mm ²)			Input null line (mm ²)	Input earth line (mm ²)
		R	S	T		
AFC-500W	15A	2mm ²			2mm ²	2mm ²
AFC-11003	19A	2.5mm ²			2.5mm ²	2.5mm ²
AFC-11005	32A	4mm ²			2.5mm ²	4mm ²
AFC-11010	65A	16mm ²			10mm ²	16mm ²
AFC-11015	97A	25mm ²			16mm ²	16mm ²
AFC-11030	194A	70mm ²			35mm ²	35mm ²
AFC-31010	22A	2.5mm ²	2.5 mm ²	2.5 mm ²	2.5 mm ²	2.5 mm ²
AFC-31015	32A	4mm ²	4mm ²	4mm ²	2.5mm ²	4mm ²
AFC-31030	65A	16mm ²	16mm ²	16mm ²	10mm ²	16mm ²
AFC-31045	97A	25mm ²	25mm ²	25mm ²	16mm ²	16mm ²
AFC-31060	129A	35mm ²	35mm ²	35mm ²	25mm ²	16mm ²
AFC-31080	197A	70mm ²	70mm ²	70mm ²	35mm ²	35mm ²
AFC-31100	247A	95mm ²	95mm ²	95mm ²	50mm ²	50mm ²
AFC-31120	296A	120mm ²	120mm ²	120mm ²	70mm ²	70mm ²
AFC-33005	11A	1mm ²	1mm ²	1mm ²	1mm ²	1mm ²
AFC-33010	22A	2.5mm ²	2.5 mm ²	2.5 mm ²	2.5 mm ²	2.5 mm ²
AFC-33015	32A	4mm ²	4mm ²	4mm ²	2.5mm ²	4mm ²
AFC-33030	65A	16mm ²	16mm ²	16mm ²	10mm ²	16mm ²
AFC-33045	97A	25mm ²	25mm ²	25mm ²	16mm ²	16mm ²
AFC-33060	129A	35mm ²	35mm ²	35mm ²	25mm ²	16mm ²
AFC-33080	197A	70mm ²	70mm ²	70mm ²	35mm ²	35mm ²

AFC-33100	247A	95mm ²	95mm ²	95mm ²	50mm ²	50mm ²
AFC-33120	296A	120mm ²	120mm ²	120mm ²	70mm ²	70mm ²
AFC-33160	395A	70mm ² *2	70mm ² *2	70mm ² *2	70mm ²	70mm ²
AFC-33200	493A	95mm ² *2	95mm ² *2	95mm ² *2	95mm ²	95mm ²

(b) Input low voltage

Input: 115V,120V						
model	Input current (A)	Input live wire (mm ²)			Input null line (mm ²)	Input earth line (mm ²)
		R	S	T		
AFC-11003	37A	6mm ²			4mm ²	6mm ²
AFC-11005	62A	10mm ²			6mm ²	10mm ²
AFC-11010	124A	35mm ²			25mm ²	16mm ²
AFC-11015	185A	70mm ²			35mm ²	35mm ²
AFC-11030	371A	150mm ²			95mm ²	95mm ²
AFC-31010	41A	6mm ²	6mm ²	6mm ²	4mm ²	6mm ²
AFC-31015	62A	10mm ²	10mm ²	10mm ²	6mm ²	10mm ²
AFC-31030	124A	35mm ²	35mm ²	35mm ²	25mm ²	16mm ²
AFC-33005	21A	2.5mm ²	2.5mm ²	2.5mm ²	2.5mm ²	2.5mm ²
AFC-33010	41A	6mm ²	6mm ²	6mm ²	4mm ²	6mm ²
AFC-33015	62A	10mm ²	10mm ²	10mm ²	6mm ²	10mm ²
AFC-33030	124A	35mm ²	35mm ²	35mm ²	25mm ²	16mm ²

Table 3-2 Output power distribution cable table

Model (Standard)	Output current (A)	Output live line (mm ²)			Output null line (mm ²)	Output earth line (mm ²)
		R	S	T		
AFC-11003	LO: 25.0A HI: 12.5A	2.5mm ²			2.5mm ²	2.5mm ²
AFC-11005	LO: 41.7A HI: 20.8A	6mm ²			4mm ²	6mm ²
AFC-11010	LO: 83.3A HI: 41.7A	16mm ²			10mm ²	16mm ²
AFC-11015	LO: 125.0A HI: 62.5A	35mm ²			25mm ²	16mm ²
AFC-11030	LO: 250A HI: 125A	95mm ²			50mm ²	50mm ²
AFC-31010	LO: 83.3A HI: 41.6A	16mm ²			10mm ²	16mm ²
AFC-31015	LO: 125A HI: 62.5 A	35mm ²			25mm ²	16mm ²
AFC-31030	LO: 250.0A HI: 125.0A	95mm ²			50mm ²	50mm ²
AFC-31045	LO: 375.0A HI: 187.5A	70mm ² *2			70mm ²	70mm ²
AFC-31060	LO: 500.0A HI: 250.0A	95mm ² *2			95mm ²	95mm ²
AFC-31080	LO: 666.7A HI: 333.3A	150mm ² *2			150mm ²	150mm ²
AFC-31100	LO: 833.3A HI: 416.7A	120mm ² *3			95mm ² *2	95mm ² *2
AFC-31120	LO: 1000A HI: 500A	150mm ² *3			120mm ² *2	120mm ² *2
AFC-33005	LO: 13.9A HI: 6.9A	1mm ²	1mm ²	1mm ²	1mm ²	1mm ²
AFC-33010	LO: 27.8A HI: 13.9A	4mm ²	4mm ²	4mm ²	2.5mm ²	4mm ²
AFC-33015	LO: 41.7A HI: 20.8A	6mm ²	6mm ²	6mm ²	4mm ²	6mm ²
AFC-33030	LO: 83.3A HI: 41.7A	16mm ²	16mm ²	16mm ²	10mm ²	16mm ²
AFC-33045	LO: 125.0A HI: 62.5A	35mm ²	35mm ²	35mm ²	25mm ²	16mm ²
AFC-33060	LO: 166.7A HI: 83.3A	50mm ²	50mm ²	50mm ²	25mm ²	25mm ²
AFC-33080	LO: 222.2A HI: 111.1A	70mm ²	70mm ²	70mm ²	35mm ²	35mm ²
AFC-33100	LO: 277.8A HI: 138.9A	120mm ²	120mm ²	120mm ²	70mm ²	70mm ²
AFC-33120	LO: 333.3A HI: 166.7A	150mm ²	150mm ²	150mm ²	95mm ²	95mm ²
AFC-33160	LO: 444.4A	70mm ² *2	70mm ² *2	70mm ² *2	70mm ²	70mm ²

	HI: 222. 2A					
AFC-33200	LO: 555. 6A HI: 277. 8A	120mm ² *2	120mm ² *2	120mm ² *2	120mm ²	120mm ²

Notice

In the above table, suggest cables use multi-core soft copper cables. Users can choose different cables according to input and output current condition. When input or output length is more than 20m, diameter of cables should be doubled.

-
- (2). Use voltage meter to confirm distribution lines without voltage output.
 - (3). Confirm all switches of variable frequency Power supply in "OFF" position.
 - (4). Connect input distribution lines to corresponding input terminals of variable frequency power supply, output load lines should be connected to corresponding output terminals of variable frequency power supply.

Notice

Wiring relation (R, S and T general correspond common red, white and blue; N line must be well connected). It is strictly forbidden to install while at AC Power "ON" status. Consider voltage drop when the distance of input and output wiring is long.

Chapter 4 Operation

4.1 Operation mode

Two types: AC power inversion mode and fault mode.

4.1.1 AC power inversion mode

After installation and connect variable frequency power supply to AC power, turn on input air breaker. After a few seconds the buzzer sounds, then press RESET button on the operation panel for more than one second. When hear the buzzer stop buzzing, the power enters inversion mode. When input AC power is in normal range, the frequency meter and voltage meter on control panel show the current setting output value.

4.1.2 Fault mode

After connecting to AC power but not pressing RESET key, or appearing output over-load, input low-voltage, output over-voltage, over-temperature, FUSE break, and inverter over-current when turning on the machine, the buzzer will sound continually, and voltage and current show no value on operation panel.

Notice

In fault mode, press RESET key to re-start. If RESET key is invalid, it says that the fault has not been eliminated, and troubleshooting needs to be done. When press RESET key, it is not recommended that re-start with load.

4.2 Normal operation

4.2.1 System initial start

In term of the mentioned manner, connect the input and output line (if there is a load, please switch off the output external breaker). Close the input switch (please confirm that the utility is normal, before you close the input switch). From now on, the power system starts, and the main fans operate. The rectifier makes use of soft-start, and the control system checks by itself. After that, the buzzers sound (illuminate that the rectifier has start already and the control system has been checked by itself). At this moment, the tables in the panel light up (voltage\current\power table display “0”, except the frequency table). After you click the RESET button in the operation panel more than 1 second, the buzzers don’t sound any more. There is output power on the power source. Please confirm the frequency, voltage, current, and the power shows compliance with the use requirements (if not consistent, please configure the output voltage and frequency through the operation panel). Close the output switch, output external switch. If there is the normal work with a load, the system initial use of power debugging completed.

 Notice

Before you close the input power switch, please confirm that the input voltage is in the normal range, and the phase sequence is right. To ensure that the initial boot security, it would be grateful if the panel voltage regulator knob counterclockwise transferred to the minimum, that is, anti-clockwise rotation in the end position.

4.2.2 Normal operation

On the normal status, output should be configured on the normal use status by the users.

- (1). Connect the utility to the rectifier, click “RESET” button more than 1second. The buzzers don’t sound any more, and the instrument in the panel directed the voltage and the frequency value after several seconds. Complete boot.
- (2). Choose the required output frequency. You can turn the frequency knob (not need shut down), until you have the required value.
Fixed output frequency: switch the frequency knob to the instructions on the “50Hz” or “60Hz”, you can gain the required fixed output frequency.
Regulated output frequency: switch the frequency knob to the instructions on the “VAR”, turn the frequency adjustable vernier knob, you can gain the required frequency range from “47Hz~63Hz”.
- (3). Standard output voltage adjustment. Make the [Three-phase voltage selection switch] switch to the [MID], and then, turn the [frequency adjustable vernier knob]. You can gain the required output voltage. At this moment, high position of the [three-phase voltage selection switch] correspond to the 110~125 percent of the rated output voltage, low position correspond to the 90~70 percent of the rated output voltage.
- (4). Configure the voltage higher than the rated 10%~25%. Make [three-phase voltage selection switch] switch to the high position, and then, turn the little knob above the high position using a little slotted screwdriver until you get the required output voltage.
- (5). Configure the voltage lower than the rated 10%~30%. Make [three-phase voltage selection switch] switch to the low position, and then, turn the little knob below the low position using a little slotted screwdriver until you get the required output voltage.

 For example

If the required output voltage is “220V±15%”, adjusted by the following steps:

$$220\text{V} \times 1.15 = 253\text{V}$$

$$220\text{V} \times 0.85 = 187\text{V}$$

Make [three-phase voltage selection switch] switch to the [MID] , and then, vernier turn the [output voltage vernier knob] , you can get 220V output voltage.

Switch [three-phase voltage selection switch] to [HIGH] position, and then, turn the knob above this position using a little slotted screwdriver until you gain the 253V output voltage.

Switch [three-phase voltage selection switch] to [LOW] position, and then, turn the knob below this position using a little slotted screwdriver until you gain the 187V output voltage.

-
- (6). After you complete above adjustment, you can close the output switch and external switch if there is nothing trouble.

 Notice

If you connect the load to the power source without setting the output voltage and the frequency, there be something wrong with your load. When the load specify the electromotor, if the motor starting current more than the over-current setting value, the variable frequency power source will be protected. Click the RESET button to restart after over-load situation be eliminated.

4.2.3 Out of power and shut down

Shutdown order: disconnect your load, switch off the output external switch, and then, switch off the output breaker. At last, switch off input breaker. At this time, the displayed disappear, and the fans stop. The power system shut down.

Chapter 5 Maintenance

5.1 Maintenance notice

- (1). Read product manual

Maintenance should pay special attention to these measures and the contents described in the product manual.

- (2). Avoid shock

Firstly, make sure that you have switched the input breaker in the panel to the “OFF” position to avoid shock; there is the electricity in the internal conductive copper, so you must not touch.

- (3). Circuit integrity

When you replace the circuit parts, please ensure the use of specified components. In any cases, do not alter any circuit (do not suggest replace the components on the PCB board. When there is something wrong, you just replace the PCB board).

- (4). Parts fixed and the rehabilitation of the entire line

Some parts are fixed with insulation tape and the rubberized fabric in order to isolate with the PCB board for security. In addition, the internal wiring need to collate, tighten up to prevent interference from heating parts, and high-voltage parts. So recovery action must do.

- (5). Safety check after maintenance

Notice

Check the screw, parts, and wiring placing after you complete the maintenance. You must make sure of the security of the variable frequency power source.

5.2 Fan

The fans expected time is 20000 to 40000 hours in the continuous operation. The higher ambient temperature, the shorter service lifetime. The fans should be checked regularly.

5.3 System inspection by eyes

- (1). Clear regularly, specially, the input and the output air channel to ensure the air flow fluently. When necessary, use dust vacuum.

- (2). Check that there is nothing on the air channel.

5.4 Quarterly maintenance

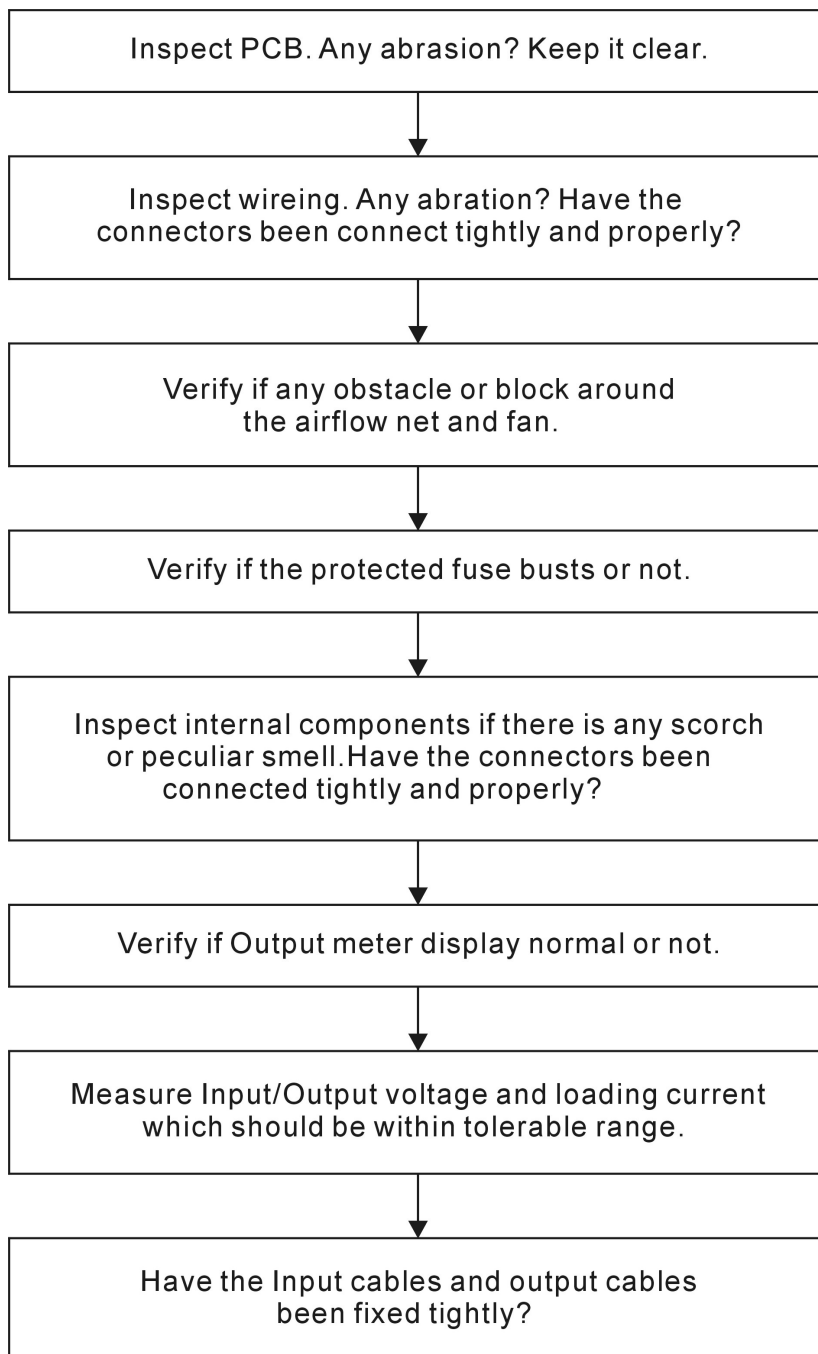

Quarterly maintenance flow chart

5.5 Yearly maintenance

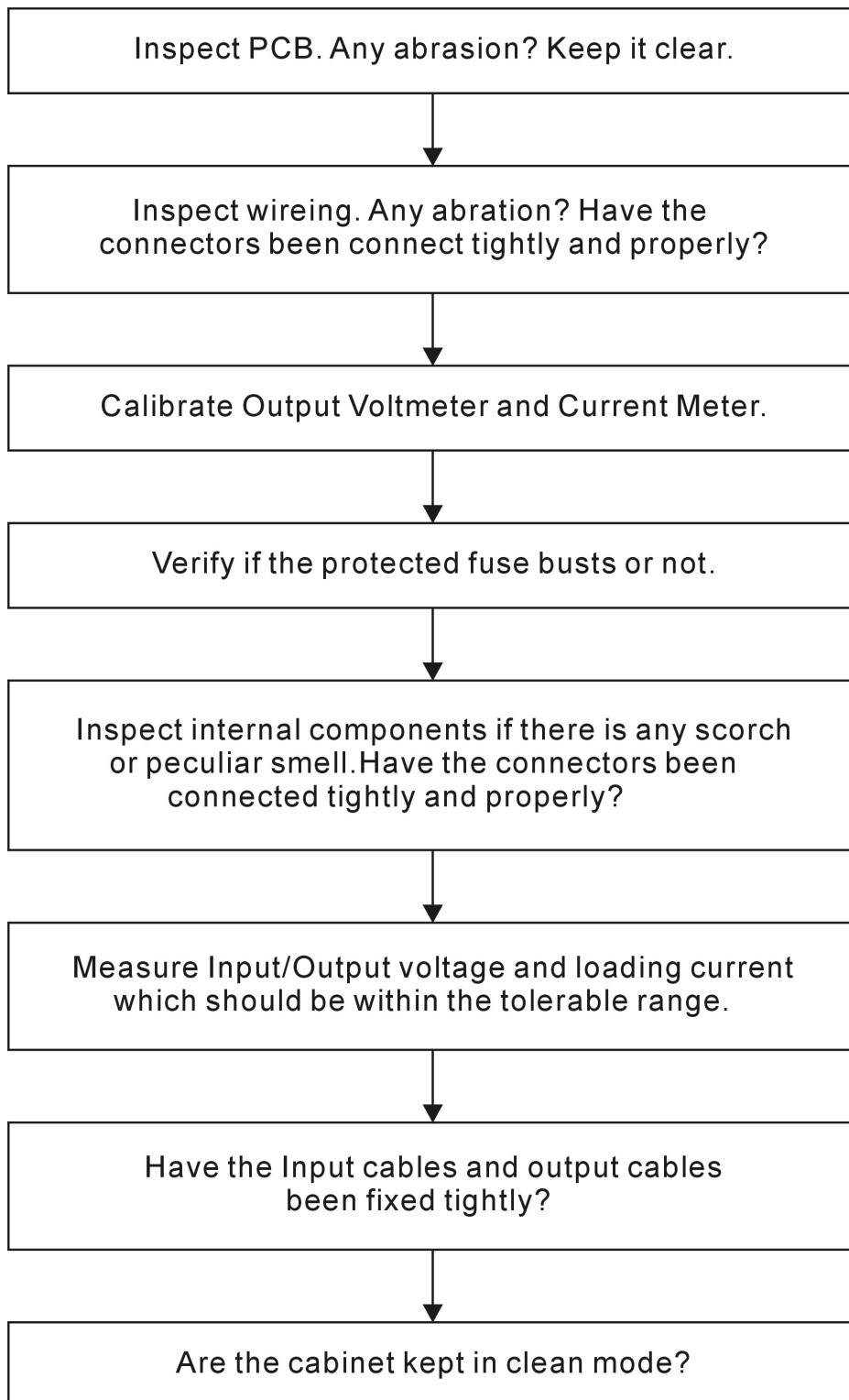

Yearly maintenance flow chart

Chapter 6 Troubleshooting

When AC power source operates abnormally, the possible causes could be narrowed down with the table below.

The error code is available on PCB AFC-PROB-3P (3Phase product) or PCB AFC-1P (single phase 5kva above), after press "RESET" button.

Please report abnormal symptoms with error code to our branches or local distributors for after-service.

NO.	description	analysis	solution
1	Don't start up, and no responses	The utility is abnormal, or connection is abnormal	Check the utility and the phase sequency of input voltage, eliminate the errors, and restart.
2	Connect the utility to the input, but cann't RESET. At this time, LED indicator display "04" in the PCB AFC-PROB-3P or PCB AFC-1P.	Input under-voltage	Check the input voltage, eliminate the errors,and restart
3	Connect the utility to the input, but cann't RESET. At this time, LED indicator display "07" in the PCB AFC-PROB-3P or PCB AFC-1P.	① R phase module error; ② R phase circuit short.	Please inform our branches or local partners for services.
4	Connect the utility to the input, but cann't RESET. At this time, LED indicator display "06" in the PCB AFC-PROB-3P.	① S phase module error; ② S phase circuit short.	Please inform our branches or local partners for services.
5	Connect the utility to the input, but cann't RESET. At this time, LED indicator display "05" in the PCB AFC-PROB-3P.	① T phase module error; ② T phase circuit short.	Please inform our branches or local partners for services.
6	Connect the utility to the input, but cann't RESET. At this time, LED indicator display "08" in the PCB AFC-PROB-3P or PCB AFC-1P.	Over-load	Remove the load till the max current within the specs of AC power source, and restart.
7	Connect the utility to the input, but cann't RESET. At this time, LED indicator display "02" in the PCB AFC-PROB-3P or PCB AFC-1P.	Internal FUSE blews	Check whether the fuse blews, if so, please inform our branches or local partners for services.
8	Connect the utility to the input, but cann't RESET. At this time, LED indicator display "01" in the PCB AFC-PROB-3P or PCB AFC-1P.	The output is over-voltage	Please inform our branches or local partners for services.
9	Connect the utility to the input, but cann't RESET. At this time, LED indicator display "03" in the PCB AFC-PROB-3P or PCB AFC-1P.	The temperature protection circuit is abnormal	Please inform our branches or local partners for services.
10	There is something wrong with the fans	Something is wrong with fans or air duct.	Clear air duct.
11	Display function is abnormal	Malfunction on meter/display or along the concerning circuit to sampling.	Please inform our branches or local partners for services.

Error code definition on PCB AFC-PROB-3P or PCB AFC-1P:

Code	Definition	Code	Definition
00	Start normally	05	IGBT over-current in T phase
01	R、S、T phase over-voltage	06	IGBT over-current in S phase
02	Fault on the fuse breaker	07	IGBT over-current in R phase
03	Over-temperature	08	over-load
04	Input under-voltage	c0	External error



Call Us 1.877.571.7901

Appendix Guarantee Card



Quality

Service

Innovation

Guarantee Card

Dear _____:

Thanks for your support and patronage, the card guarantee that if your purchasing variable frequency power supply product (Model:_____, serial number:_____) is in normal use, and the machine is failure because of careless mistake of program or degradation of component, Preen bears full responsibility for after-sales service with free of charge. within one year.

Notice:

Machine should be correct installation and use. It can not be to modified structure, circuit or spare parts by users.

1. If machine is failure, please call us or send the machine back to our company with proper packaged and indicating the fault. We will serve for you as soon as possible.
2. If continue to save the card after the warranty period, we will charge reasonable fee after completion maintenance.

Deputy: _____

Date: _____