









# AM225T

Extending Scissor Mount with Tilt for Flat-Panels up to 225 lb.



-  37.00 - 63.00 in.
-  225 lb.
-  5.47 in.
-  21.00 - 21.00 in.
-  +10.00°/-0.00°
-  45°
-  800 x 525 max.
-  200 x 200 min.

## Description

The AM225T scissor-style mount supports displays up to 225 lb. and provides smooth and easy adjustments from the wall. It extends 20 in. from the wall, offers ten degrees of continuous tilt and provides 45° of swivel to both sides. Post-installation leveling enables fine-tune vertical adjustment of the display after installation. The AM225 wall mounting brackets are designed to easily attach to 12 or 16 in. studs. The open design makes it easy to set up cable and electrical wiring while the included zip ties keep cables out of the way of the mount's motion path. Built-in lateral shift allows for flexible flat-panel placement.

## AM225T Features

- Extends 21 in. straight out from the wall
- Includes P4263T mount, providing 10° of downward tilt
- 45° of swivel
- Post-installation leveling system
- Open design for easy cable and electrical access
- Built-in lateral shift

# Touchboards

205 Westwood Ave, Long Branch, NJ 07740  
Phone: 866-94 BOARDS (26273) / (732)-222-1511  
Fax: (732)-222-7088 | E-mail: sales@touchboards.com

# AM225T

Extending Scissor Mount with Tilt for Flat-Panels up to 225 lb.

WEIGHT	0.00 lb.
WEIGHT CAPACITY	225 lb.
WIDTH	33.25 in.
HEIGHT	22.60 in.
DEPTH	5.47 in.
DISPLAY RANGE	37.00 - 63.00 in.
TILT	+10.00° / -0.00°
EXTENSION	21.00 - 0.00 in.
SWIVEL	45°
MOUNTING PATTERN	Range 200 x 200 - 800 x 525

## ACCESSORIES



**GB-INWAVPB** MSRP **\$84.00**  
In-wall A/V and Power GearBox™



**SHLF-VC** MSRP **\$90.00**  
Video Conference Shelf for P-Series



**SHLF-VE** MSRP **\$199.00**  
A/V Shelving System for P-Series Mounts

MSRP **\$700.00**

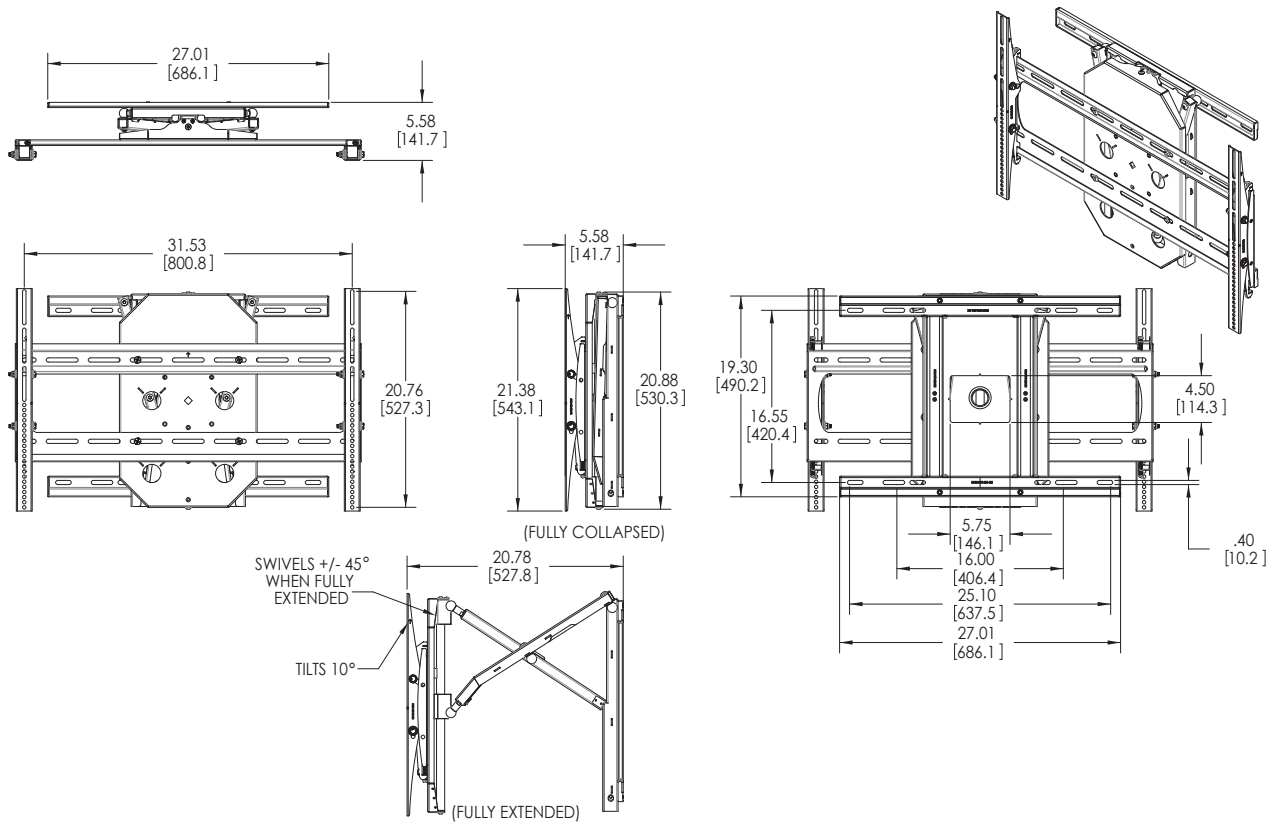

205 Westwood Ave, Long Branch, NJ 07740  
Phone: 866-94 BOARDS (26273) / (732)-222-1511  
Fax: (732)-222-7088 | E-mail: sales@touchboards.com