

8 7 6 5 4 3 2 1

THE INFORMATION CONTAINED IN THIS DRAWING IS THE SOLE PROPERTY OF PREMIER MOUNTS DIVISION OF <PMPI>. ANY REPRODUCTION IN PART OR WHOLE WITHOUT THE WRITTEN PERMISSION OF PREMIER MOUNTS DIVISION OF <PMPI> IS PROHIBITED.

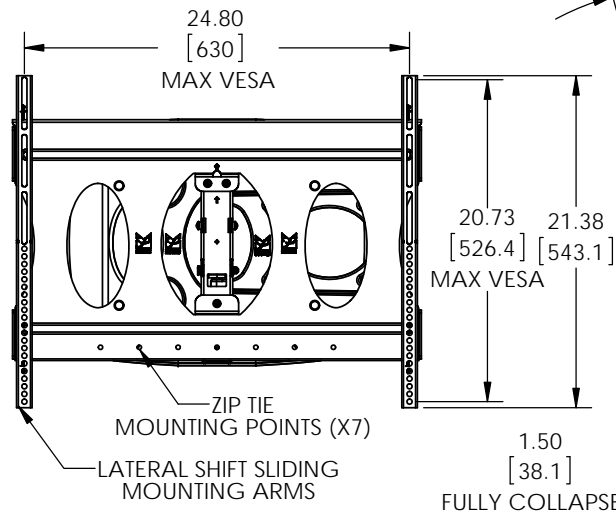
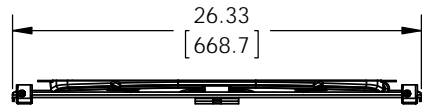

POST-INSTALLATION LEVELING SCREWS

15° TILT

LOCKING SCREWS

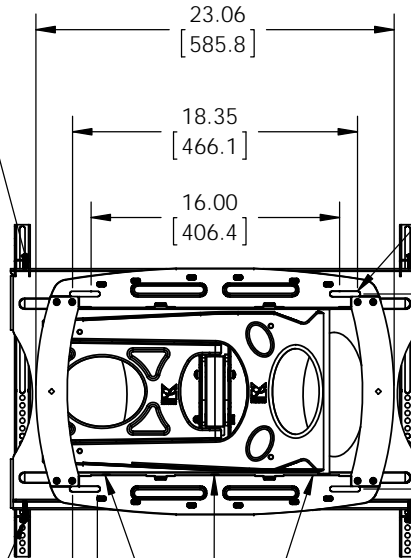

X4 SLOTS FOR LATERAL SHIFT ADJ.

3 ARM LOCATION OPTIONS FOR SWING OUT DIRECTION (TOP AND BOTTOM)

ARM PIVOTS 180°

OPEN FOR IN-WALL BOX (OPTION)

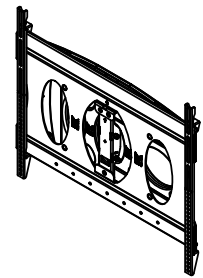

FULLY COLLAPSED

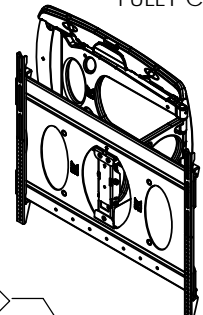

SIDE SWING

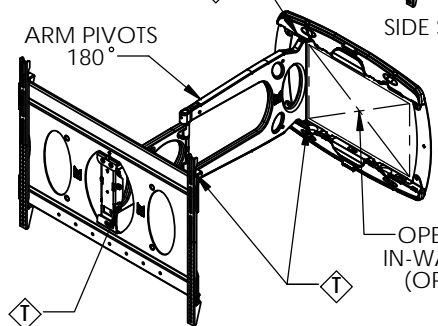

FULLY EXTENDED

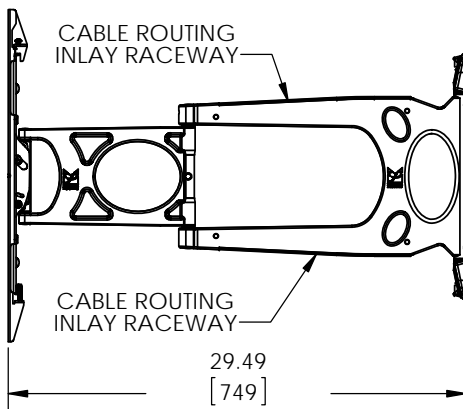

CABLE ROUTING INLAY RACEWAY

CABLE ROUTING INLAY RACEWAY

FULLY EXTENDED

Touchboards

205 Westwood Ave, Long Branch, NJ 07740
 Phone: 866-94 BOARDS (26273) / (732)-222-1511
 Fax: (732)-222-7088 | E-mail: sales@touchboards.com

⚡: TENSION ADJUSTMENT
 WEIGHT CAPACITY: 100 LBS
 DIMENSION ARE IN INCH AND [MM]

PREMIER MOUNTS
 THE ORIGINAL MOUNT COMPANY

ITEM DESCRIPTION:
 LOW PROFILE ULTRA SLIM SWINGOUT ARM

SIZE: B DWG. NO.: AM100

SCALE: 1:8 SHEET 1 OF 1

MOUNTS.COM

8 7 6 5 4 3 2 1