

# Unistrut Attached Flat Panel Menu Board Mounting Solution

Model: UMB-DBT

Weight Capacity: 75 lbs / 34 kg

## Features

- 1** Attaches to commercially available slotted channel strut
- 2** Simple design for rapid install for less downtime
- 3** 0-15° degrees of locking tilt ensures uniform screen angles
- 4** Adjustable foot pads to overcome uneven walls

The UMB-DBT & UMB-DBTS menu board flat panel display brackets are a “no assembly required” system where, out of the box, brackets that hang on the panels and are designed to attach direct to slotted channel strut offering a quick and simple way to install a linear row of displays. This technology, along with less components, enables a fast, hassle-free installation process and a number of configuration options.



Installation safely secures digital signage in place



Allows video walls and digital displays to be positioned flat or up to 15 degrees

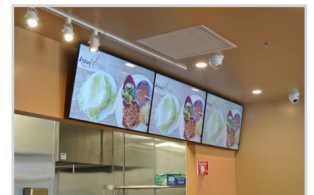

The most cost-effective digital menu board mounts on the market today

# Unistrut Attached Flat Panel Menu Board Mounting Solution

UMB-DBT

## Specifications

Weight 7lbs / 3.17 kg	Color Black	Weight Capacity / Mount 75 lbs.   34 kg	Mounting Pattern 200 x 200 mm (min) x 400 x 400 mm (Max)
Width x Height x Depth 16.5 x 2.63 x 1.9 in   419 x 66.6 x 48.3 mm		Warranty Lifetime	

## Packaging

Width x Height x Depth 23-3/4 x 6-7/8 x 3 3/8   603.3 x 174.6 x 85.7 mm
--

Contents Adapter Arms (x 2)
--------------------------------

## Architectural Drawing

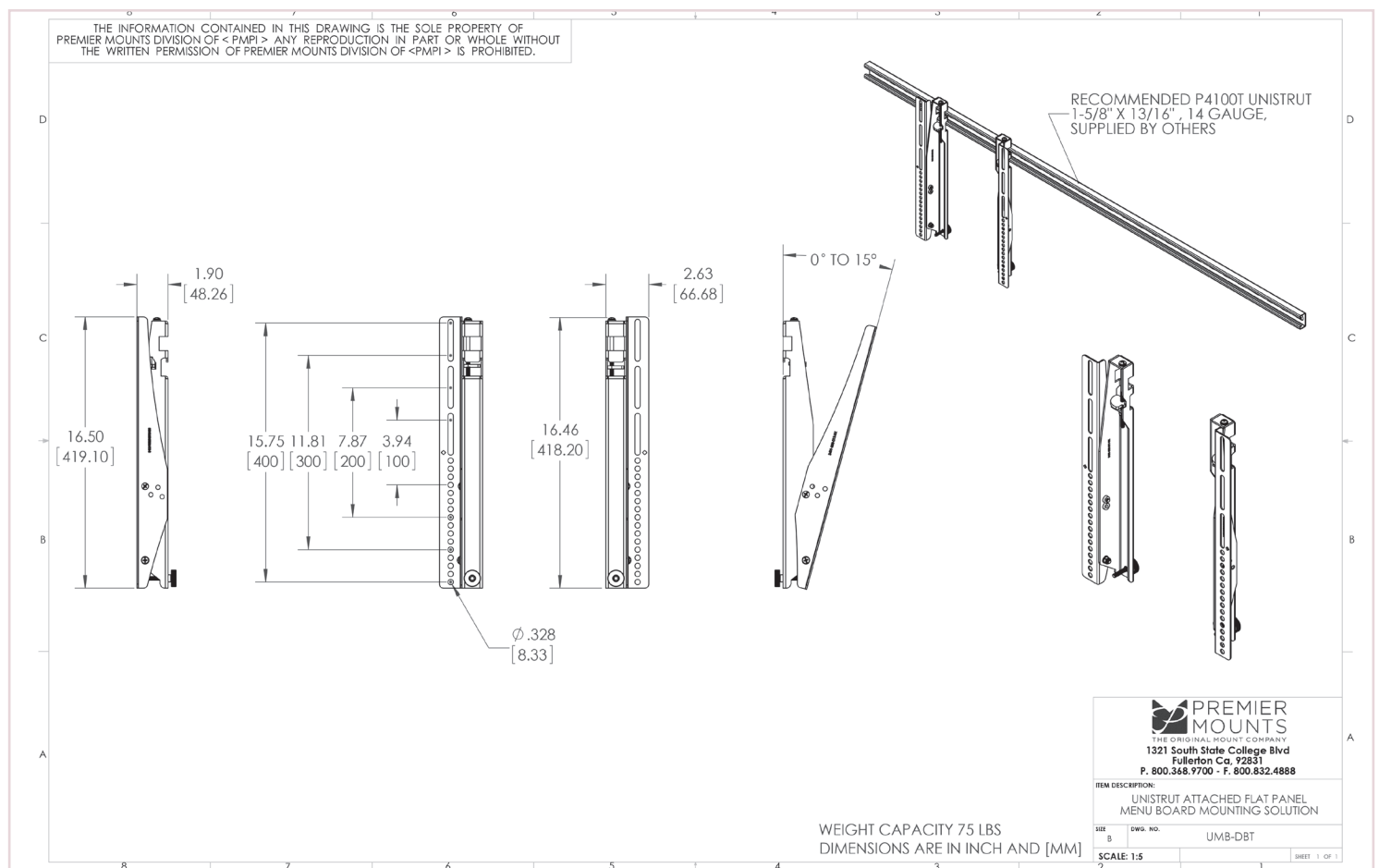

Specifications subject to change without notice

T: 800.368.9700 Int'l: +001.714.632.7100 | www.mounts.com | 1321 S. State College Blvd., Fullerton, CA 92831 USA



Visit [mounts.com](http://mounts.com) to see the complete line of AV solutions from Premier Mounts, including flat-panel mounts, projector mounts, carts/stands, and a full assortment of accessories.  
© 2015 Premier Mounts. All rights reserved.

Rev. 04-15-09