

8 7 6 5 4 3 2 1

THE INFORMATION CONTAINED IN THIS DRAWING IS THE SOLE PROPERTY OF PREMIER MOUNTS DIVISION OF <PMPI> ANY REPRODUCTION IN PART OR WHOLE WITHOUT THE WRITTEN PERMISSION OF PREMIER MOUNTS DIVISION OF <PMPI> IS PROHIBITED.

D
C
B
A

D
C
B
A

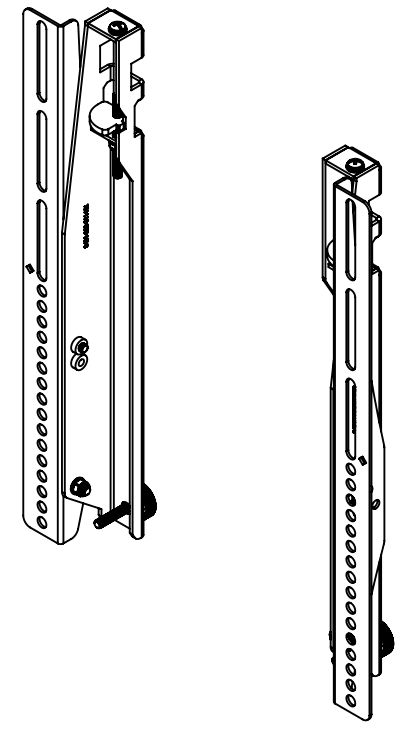
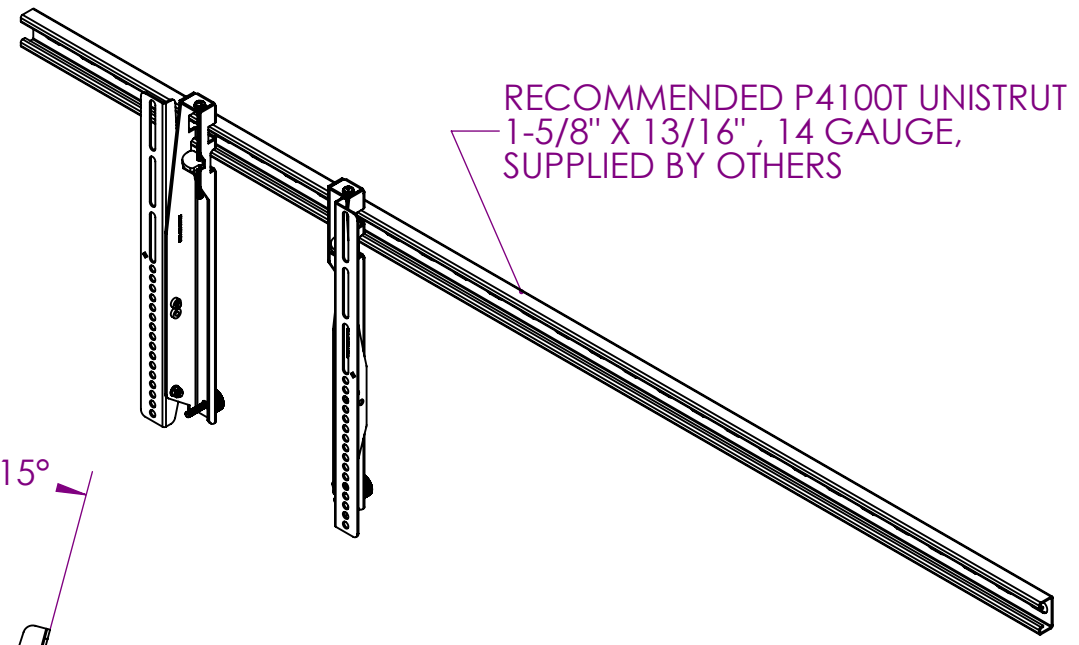
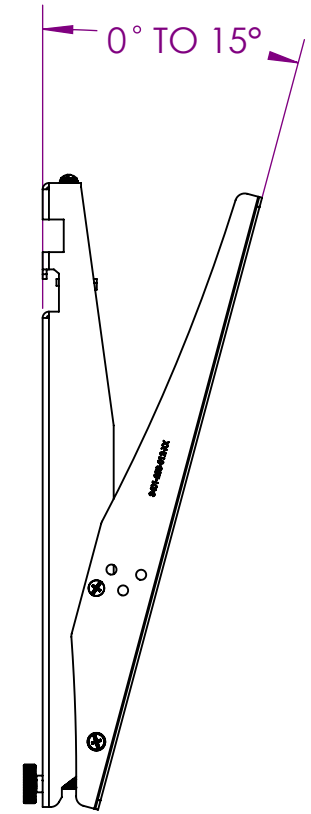
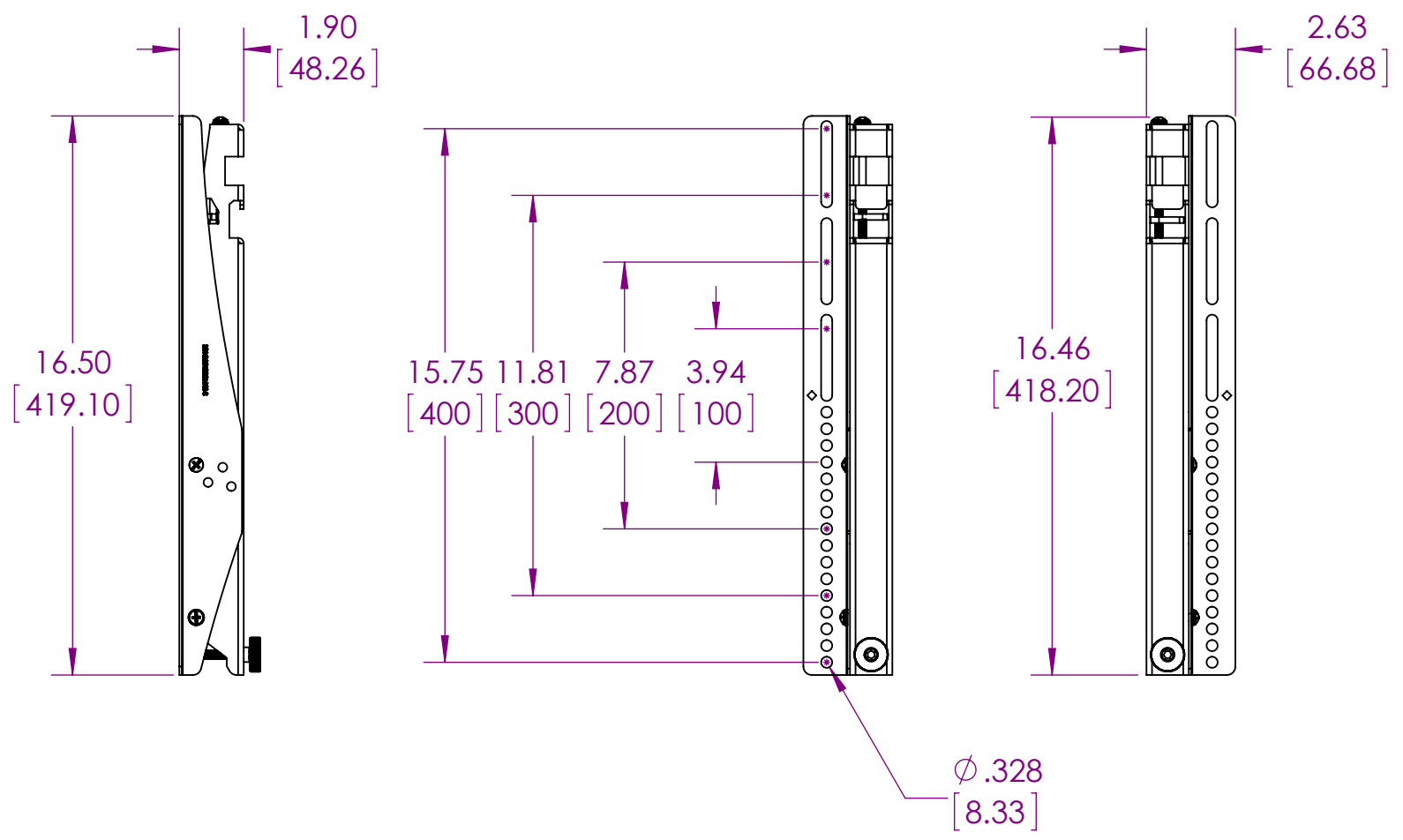

WEIGHT CAPACITY 75 LBS
DIMENSIONS ARE IN INCH AND [MM]

PREMIER MOUNTS
THE ORIGINAL MOUNT COMPANY
1321 South State College Blvd
Fullerton Ca, 92831
P. 800.368.9700 - F. 800.832.4888

ITEM DESCRIPTION:
UNISTRUT ATTACHED FLAT PANEL
MENU BOARD MOUNTING SOLUTION

SIZE B	DWG. NO. UMB-DBT
SCALE: 1:5	
SHEET 1 OF 1	

8 7 6 5 4 3 2 1