

Unistrut Attached Flat Panel Menu Board Mounting Solution

Model: UMB-DBTS

Weight Capacity: 75 lbs / 34 kg

Features

- 1** Attaches to commercially available slotted channel strut
- 2** Simple design for rapid install for less downtime
- 3** 0-15° degrees of locking tilt ensures uniform screen angles
- 4** Adjustable foot pads to overcome uneven walls

The UMB-DBT & UMB-DBTS menu board flat panel display brackets are a “no assembly required” system where, out of the box, brackets that hang on the panels and are designed to attach direct to slotted channel strut offering a quick and simple way to install a linear row of displays. This technology, along with less components, enables a fast, hassle-free installation process and a number of configuration options.

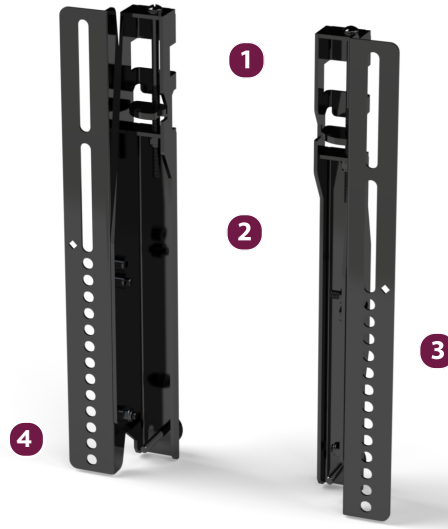

Installation safely secures digital signage in place



Allows video walls and digital displays to be positioned flat or up to 15 degrees

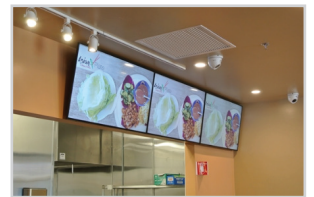

The most cost-effective digital menu board mounts on the market today

Unistrut Attached Flat Panel Menu Board Mounting Solution

UMB-DBTS

Specifications

Weight 6.5 lbs / 2.48 kg	Color Black	Weight Capacity / Mount 75 lbs. 34 kg	Mounting Pattern 200 x 200 mm (min) x ∞ x 300 mm (Max)
Width x Height x Depth 13.5 x 2.6 x 1.9 in 342.9 x 66.7 x 48.3		Warranty Lifetime	

Packaging

Width x Height x Depth 23-3/4 x 6-7/8 x 3 3/8 603.3 x 174.6 x 85.7 mm	Contents Adapter Arms (x 2)
--	--------------------------------

Architectural Drawing

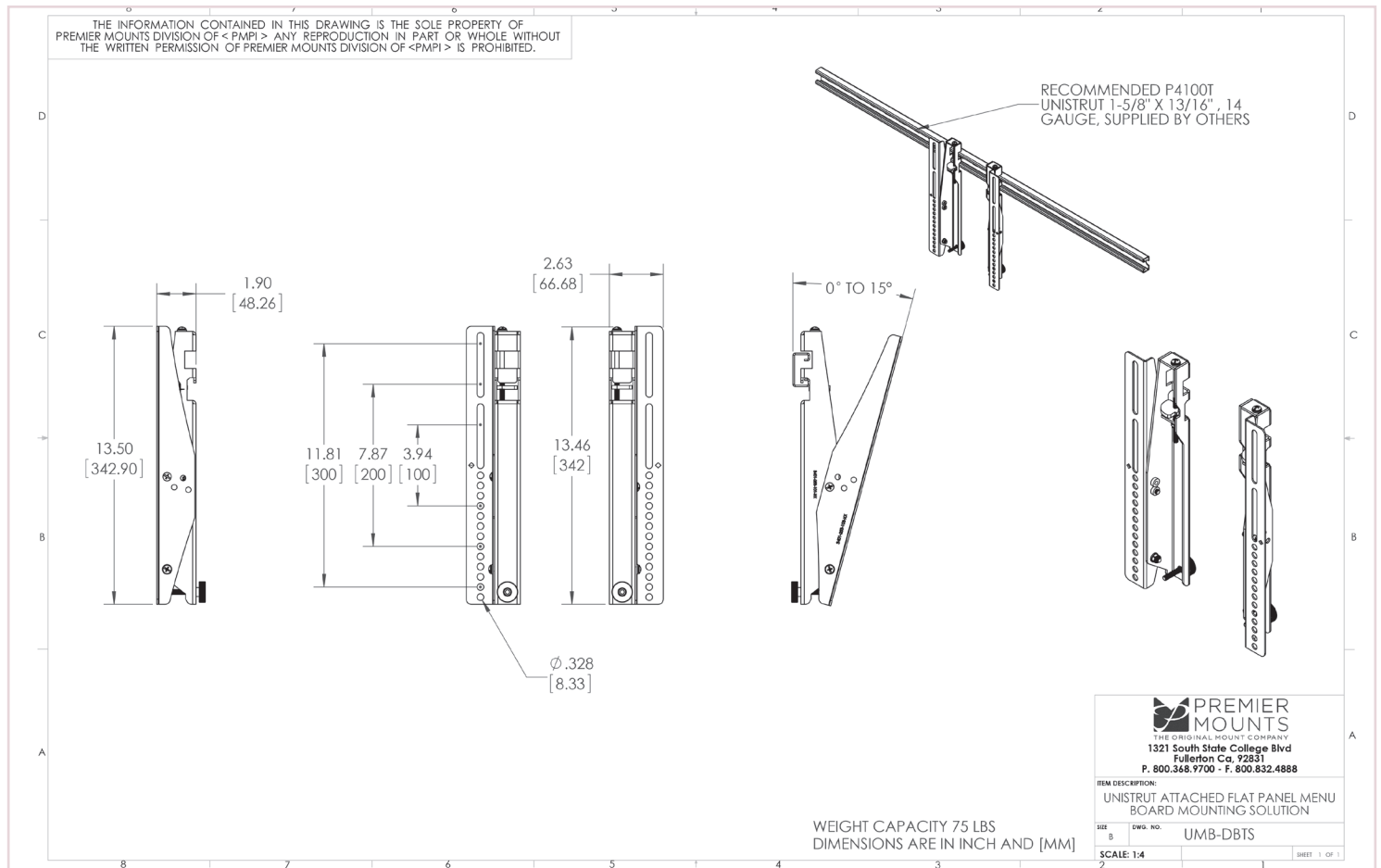

Specifications subject to change without notice