

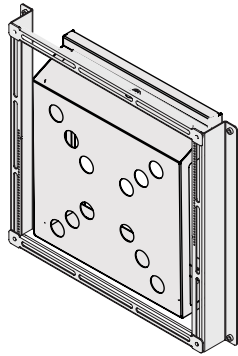

Storage GearBox™ for CTM-MS2 Tilting Mount - Installation Instructions

Introduction



The storage GearBox™ for the CTM-MS2 tilting mount (GB-MS2) securely holds a PC tower or similar-sized A/V equipment in between the flat-panel and mount. This space-saving feature helps efficiently organize your A/V installation for many applications, such as digital signage or corporate use. The GB-MS2 is a great alternative to storing electronics in false ceilings or bulky floor boxes.

Parts List

| | | |
|---------------------------------------|-------------------------|--|
| | | |
| Media Box (Qty 1) | Key (Qty 2) | Extension Bracket (Qty 2) |
| | | |
| Horizontal Support Bracket (Qty 2) | M8 Nylon Nut (Qty 4) | M8 x 12mm Pan Phillips Screw (Qty 4) |

Step 1

Follow the instructions in the CTM-MS2 manual up to page 7.



Stop at the end of the manual's "Installing the Wall Plate" section.

Step 2

Insert a PC tower or similar-sized A/V equipment into the media box.

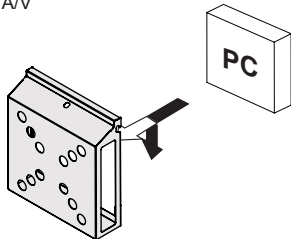

Step 3

- 1) Insert the media box between the brackets and the wall plate.
- 2) Hook the media box on the top rail of the wall plate.



The lock on the media box must be in the unlocked position, or else it will not fit over the rail.

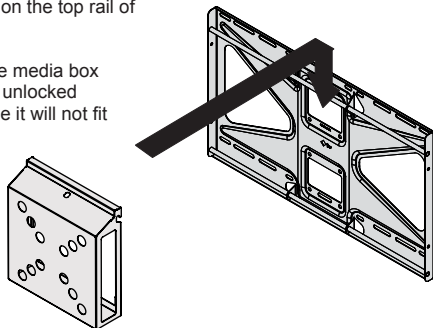

Step 4

Use four (4) M8 x 12mm pan Phillips screws to attach two (2) extension brackets to the mounting brackets of the CTM-MS2 as shown.



Insert the screws through the back of the PEM nuts on the extension brackets.

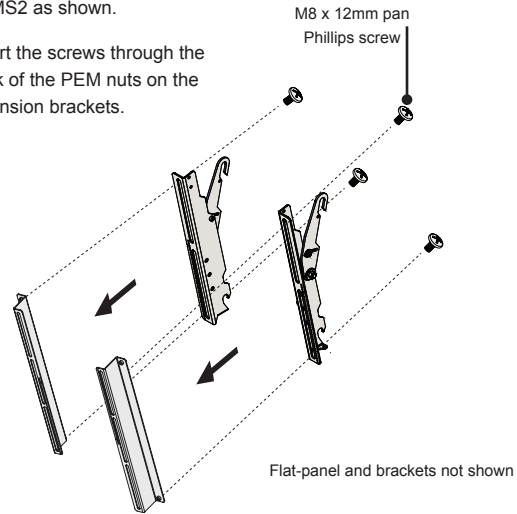

Mounting brackets are included with the CTM-MS2.
Screws are not to scale.

Step 5



Is the mounting pattern on the flat-panel wider than the media box?

If **Yes**, do not use the horizontal support brackets. Skip to **Step 7**.

If **No**, continue to **Step 6**.

• All trademarks are the property of the respective trademark owners.



Step 6

Screws are not to scale.

Use four (4) M8 nylon nuts to attach two (2) horizontal support brackets to the extension brackets (Figure 1).



Insert the nuts on the pegs that are on the backs of the horizontal support brackets (Figure 2).

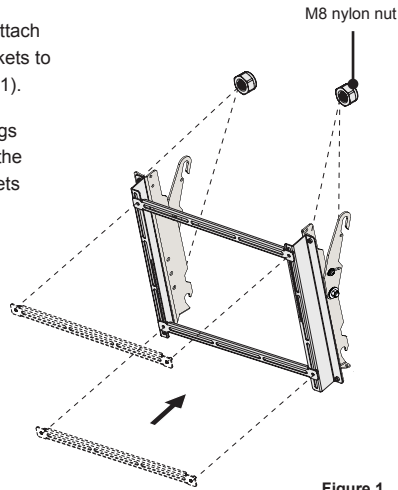

Figure 1

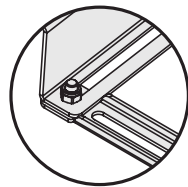

Figure 2

Step 7

Follow the rest of the instructions in the CTM-MS2 manual (starting on page 8) to attach the mounting brackets and extension brackets to the flat-panel and wall plate.

- If you are using the horizontal support brackets, attach the flat-panel mounting hardware to the **horizontal support brackets** instead of the mounting brackets (Figure 1).
- If you are **not** using horizontal support brackets, attach the flat-panel mounting hardware directly to the **extension brackets** instead of the mounting brackets (Figure 2).



The flat-panel mounting hardware is included with the CTM-MS2.

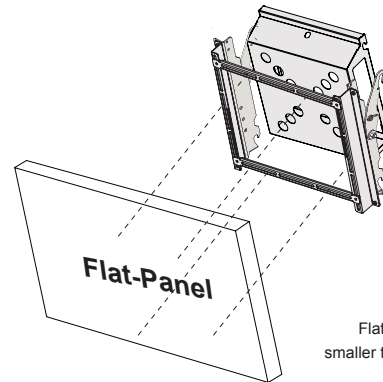

Figure 1

Flat-panel mounting pattern smaller than width of media box. CTM-MS2 not shown.

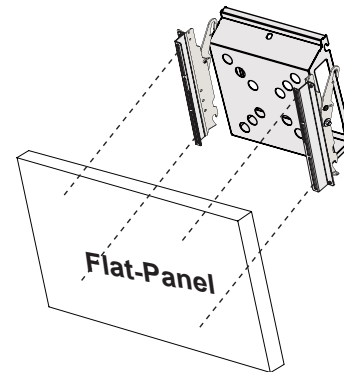
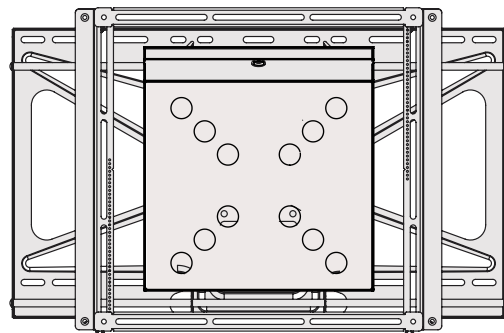

Figure 2

Flat-panel mounting pattern wider than media box. CTM-MS2 not shown.

Step 8

Once the flat-panel is hung, route cables and electrical wiring through the openings in the CTM-MS2 and media box.



Front view of CTM-MS2 and GB-MS2 with horizontal support brackets



205 Westwood Ave, Long Branch, NJ 07740
 Phone: 866-94 BOARDS (26273) / (732)-222-1511
 Fax: (732)-222-7088 | E-mail: sales@touchboards.com