

INSTALLATION INSTRUCTIONS

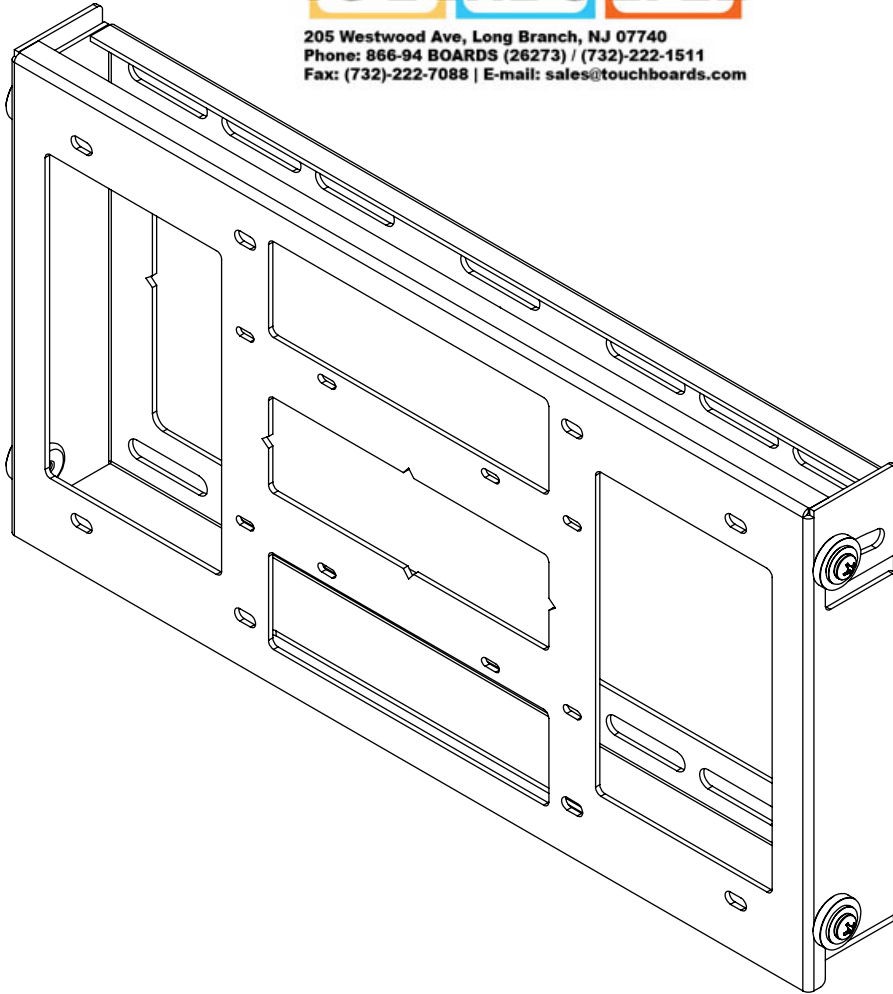

205 Westwood Ave, Long Branch, NJ 07740
Phone: 866-94 BOARDS (26273) / (732)-222-1511
Fax: (732)-222-7088 | E-mail: sales@touchboards.com



GB-VESA42

VESA Tilting GearBox Mount

NORTH AMERICA

3130 East Miraloma Avenue
Anaheim, CA 92806 USA
USA and Canada
Phone: 1-800-368-9700
Fax: 1-800-832-4888
Other Locations
Phone: (001)-714-632-7100
Fax: (001)-714-632-1044

EUROPE

Swallow House,
Shilton Industrial Estate,
Shilton, Coventry, England CV79JY
Phone: +44 (0) 2476 614700
Fax: +44 (0) 2476 614710



Contents

Weight Limit..... 2

Warning Statements..... 2

Installation Tools..... 3

Parts List..... 3

Mounting Hardware..... 4

Features..... 5

Installing the Wall Plate..... 6

 Determining the Mounting Surface..... 6

 Wood Stud Installation..... 6

 Concrete Installation..... 8

Mounting Hardware..... 9

 Selecting the Mounting Hardware..... 9

 Universal Spacer Installation..... 10

Attaching the Mounting Bracket to the Flat Panel..... 10

Attaching the Flat Panel to the Wall Plate..... 10

Securing the GB-VESA42 Mount..... 11

Technical Specifications..... 11

Warranty..... 12

Weight Limit

Maximum Flat Panel Weight: **50 lbs.**

THE WALL STRUCTURE MUST BE CAPABLE OF SUPPORTING AT LEAST FIVE TIMES THE WEIGHT OF THE FLAT PANEL. IF NOT, THE WALL STRUCTURE MUST BE REINFORCED.

Warning Statements



PRIOR TO THE INSTALLATION OF THIS PRODUCT, THE INSTALLATION INSTRUCTIONS MUST BE READ AND COMPLETELY UNDERSTOOD. KEEP THESE INSTALLATION INSTRUCTIONS IN AN EASILY ACCESSIBLE LOCATION FOR FUTURE REFERENCE.



PROPER INSTALLATION PROCEDURE BY A QUALIFIED SERVICE TECHNICIAN MUST BE FOLLOWED, AS OUTLINED IN THESE INSTALLATION INSTRUCTIONS. FAILURE TO DO SO COULD RESULT IN PROPERTY DAMAGE, SERIOUS PERSONAL INJURY, OR EVEN DEATH.



SAFETY MEASURES MUST BE PRACTICED AT ALL TIMES DURING THE ASSEMBLY OF THIS PRODUCT. USE PROPER SAFETY EQUIPMENT AND TOOLS FOR THE ASSEMBLY PROCEDURE TO PREVENT PERSONAL INJURY.



PREMIER MOUNTS DOES NOT WARRANT AGAINST DAMAGE CAUSED BY THE USE OF ANY PREMIER MOUNTS PRODUCT FOR PURPOSES OTHER THAN THOSE FOR WHICH IT WAS DESIGNED OR DAMAGE CAUSED BY UNAUTHORIZED ATTACHMENTS OR MODIFICATIONS, AND IS NOT RESPONSIBLE FOR ANY DAMAGES, CLAIMS, DEMANDS, SUITS, ACTIONS OR CAUSES OF ACTION OF WHATEVER KIND RESULTING FROM, ARISING OUT OF OR IN ANY MANNER RELATING TO ANY SUCH USE, ATTACHMENTS OR MODIFICATIONS.



At least two qualified people should perform the assembly procedure. Personal injury and/or property damage can result from dropping or mishandling the flat panel.



If mounting to wall studs or ceiling studs, make sure that the mounting screws are anchored into the center of the wall studs or ceiling studs. Use of an edge-to-edge stud finder is recommended.



It is recommended that a maximum of 5/8" plaster board be used when mounting to wooden studs.



Be aware of the mounting environment. If drilling and/or cutting into the mounting surface, always make sure that there are no electrical wires in wall. Cutting or drilling into an electrical line may cause serious personal injury.



Make sure there are no water or natural gas lines inside the wall where the mount is to be located. Cutting or drilling into a water or gas line may cause severe property damage or personal injury.



This product is intended for indoor use only. Use of this product outdoors could lead to product failure and/or serious personal injury.



Do not install near sources of high heat. Do not install on a structure that is prone to vibration, movement or chance of impact.











Contact Premier Mounts with any questions:
(800) 368-9700
techsupport@mounts.com

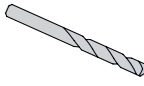
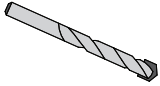
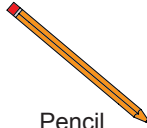
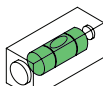

Installation Tools

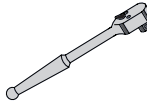
The following tools may be required, dependent upon your particular installation. These tools are not provided by Premier Mounts, but you can purchase them at your local hardware store.

 Electronic Stud Finder	 Hand Held Drill	 1/4" Wood Drill Bit	 5/16" Masonry Drill Bit**	 Pencil	 Level
 Protective Eyewear	 Hammer**	 Tape Measure	 Phillips Tip Screwdriver	 Socket Wrench	 M10 Socket**

** Optional tools for concrete installations.

Parts List

Your Premier Mounts product is shipped with all proper installation hardware and components. Make sure that none of these parts are missing and/or damaged before beginning installation. If there are parts missing and/or damaged, please stop the installation and contact Premier Mounts (800) 368-9700.

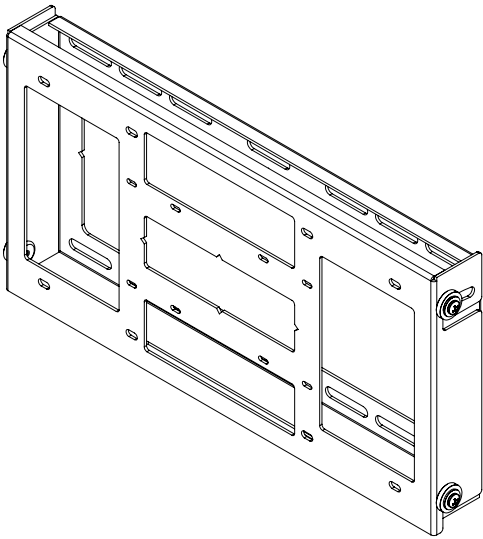
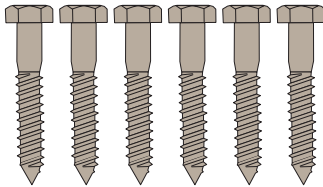
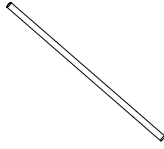
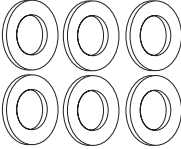
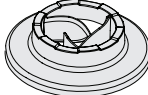
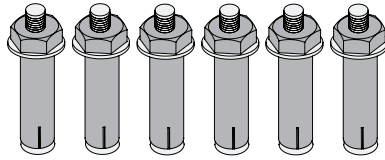
GB-VESA42 Wall Mount Components		
	 5/16" x 3" Lag Bolts (Qty 6)	 Thread Depth Indicator (Qty 1)
	 5/16" Flat Washers (Qty 6)	 Universal Spacers (Qty 30)
	 5/16" Concrete Wedge Anchors (Qty 6)	



Parts List (cont'd)

Mounting Hardware

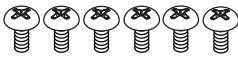
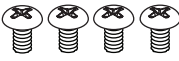
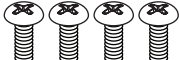
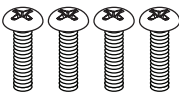
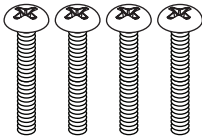
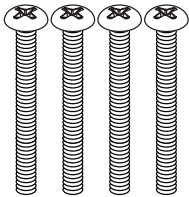
M4 x 10mm Phillips Head Screw (Qty 6)	
M5 x 10mm Phillips Head Screw (Qty 4)	
M5 x 16mm Screw (Qty 4)	
M5 x 20mm Phillips Head Screw (Qty 4)	
M5 x 30mm Phillips Head Screw (Qty 4)	
M5 x 45mm Phillips Head Screw (Qty 4)	

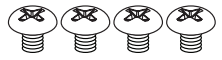
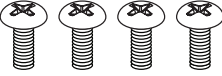
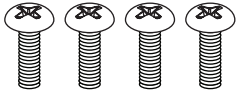
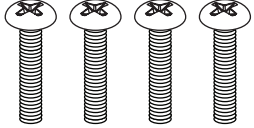
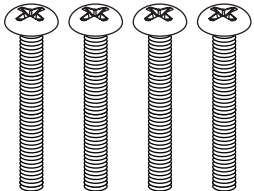
M6 x 10mm Phillips Head Screw (Qty 4)	
M6 x 16mm Phillips Head Screw (Qty 4)	
M6 x 20mm Phillips Head Screw (Qty 4)	
M6 x 30mm Phillips Head Screw (Qty 4)	
M6 x 45mm Phillips Head Screw (Qty 4)	



Features

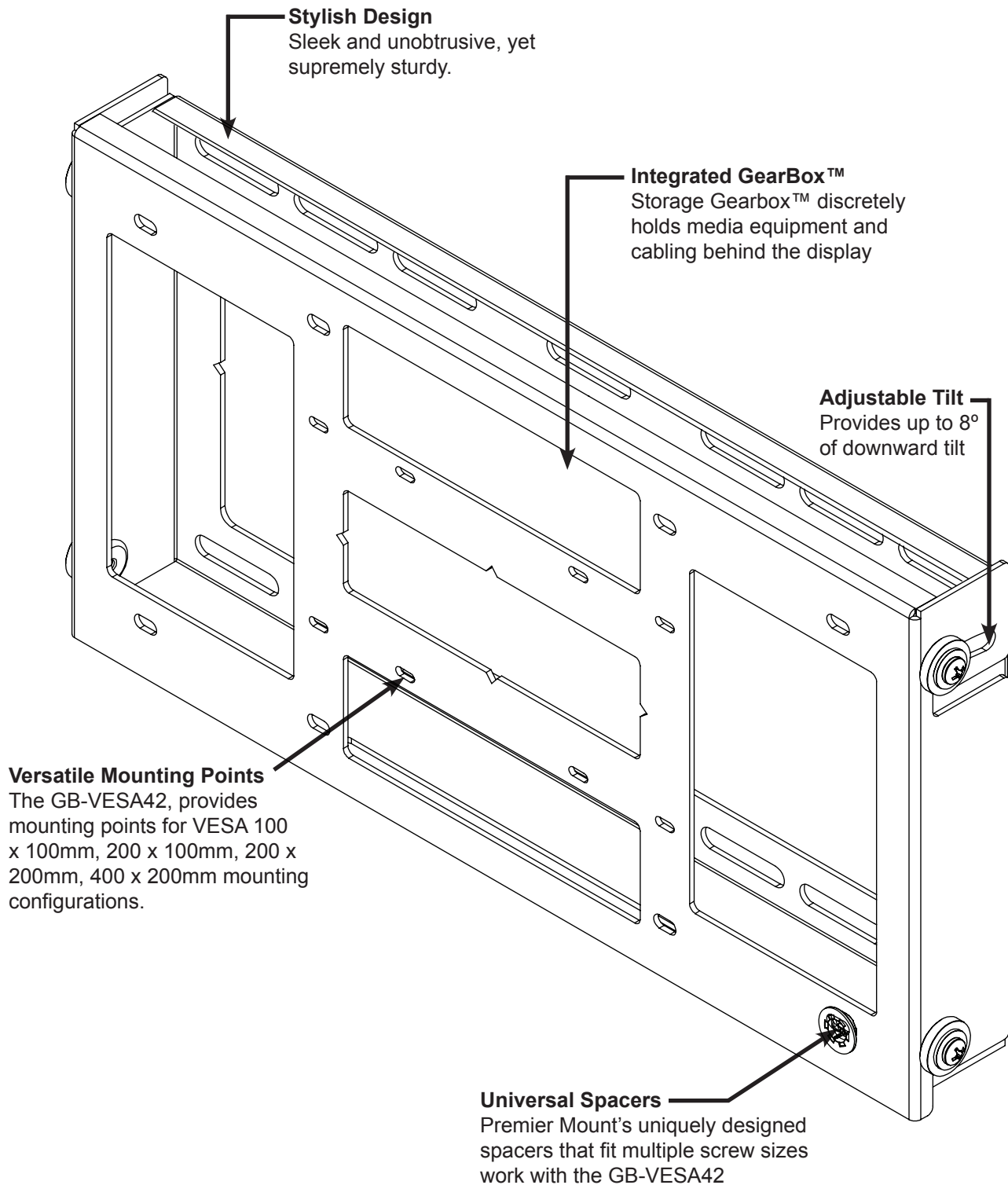



Installing the Wall Plate

Determining the Mounting Surface

If you will be installing your GB-VESA42 mount to wood studs, proceed to the “**Wood Stud Installation**” section.
If you will be installing your GB-VESA42 mount to a concrete wall, proceed to the “**Concrete Installation**” section.

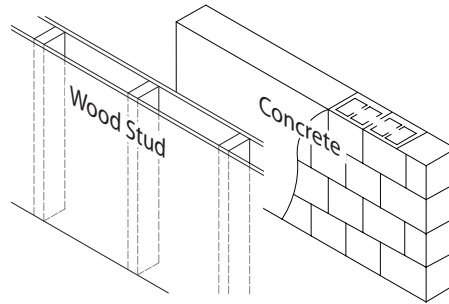

Separating the Mounting Plates

- 1) Loosen the (4) M6x12 screws from all the points labeled (A) on the figure.
- 2) Lift up to separate the front mounting plate from the back wall plate.

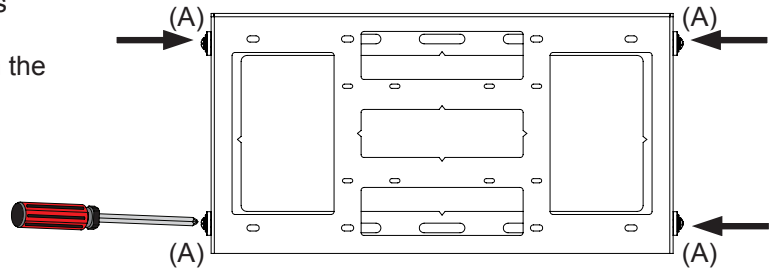

Wood Stud Installation

Step 1

 You must secure the wall plate to two (2) wall studs with a minimum of four (4) lag bolts (2 lag bolts for each stud found).

- 1) Use a stud finder to determine the exact center of wall studs in the vicinity of the wall plate.
- 2) Use a pencil to mark the exact center of the wall stud where you will be installing your GB-VESA42 mount.

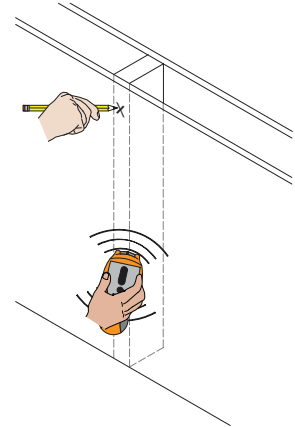

Step 2

 Two people are recommended for this step; one person to level the wall plate and another person to mark the wall stud location.

- 1) Place the wall plate against the wall in the desired viewing location.
- 2) Adjust the wall plate to align the mounting points in the wall plate with the center of the wall stud.
- 3) Level the wall plate.
- 4) Use a pencil to mark the upper right mounting location along the center of the wall stud.

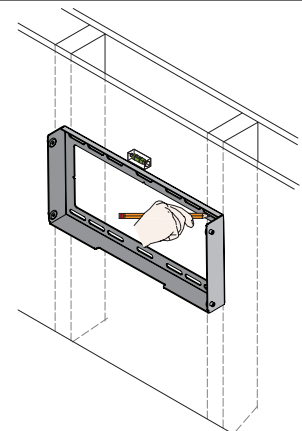



Installing the Wall Plate (cont'd)

Step 3

Drill a "pilot hole" in the center of the upper right mark using a $\frac{1}{4}$ " drill bit and power drill.



Only use a $\frac{1}{4}$ " drill bit when drilling the pilot holes.

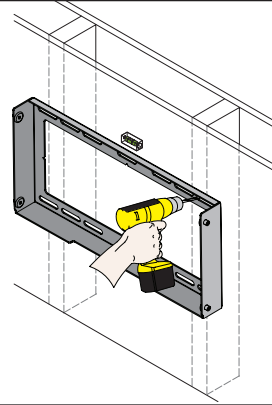

Step 4

- 1) Place the wall plate against the wall and align it with the pilot hole.
- 2) Insert one (1) $\frac{5}{16}$ " x 3" lag bolt and one (1) $\frac{5}{16}$ " washer into the upper right mounting hole and tighten using a socket wrench and $\frac{1}{2}$ " socket.



Do not overtighten the lag bolt.

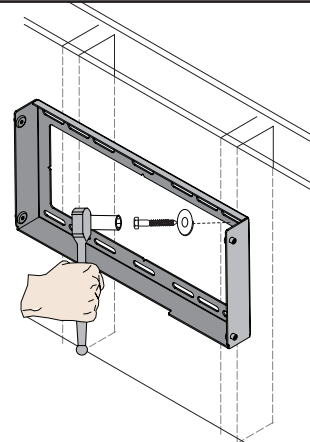

Step 5

- 1) Level the wall plate.
- 2) Use a pencil to mark the remaining three (3) mounting locations along the center of each wall stud.

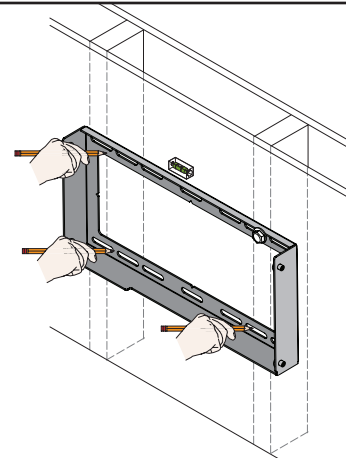

Step 6



Two people are recommended for this step; one person to level the wall plate and another person to drill the pilot holes.

Drill a "pilot hole" in the center of each of the marks with a power drill and a $\frac{1}{4}$ " drill bit.



Only use $\frac{1}{4}$ " drill bit when drilling the pilot holes.

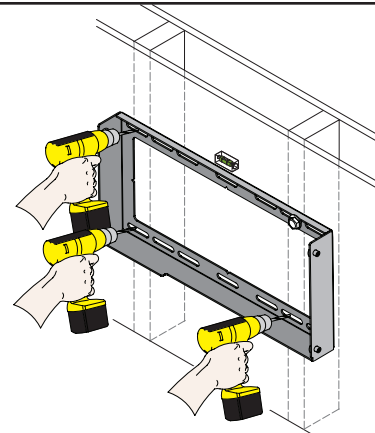



Installing the Wall Plate (cont'd)

Step 7

- 1) Insert one (1) $\frac{5}{16}$ " x 3" lag bolt and one (1) $\frac{5}{16}$ " washer into each pilot hole.
- 2) Tighten all lag bolts using a socket wrench and $\frac{1}{2}$ " socket.

 Do not overtighten the lag bolts when attaching the mount to the wall. Improper installation may result in personal injury or property damage.

Proceed to the "Installing the Front Bracket" section.

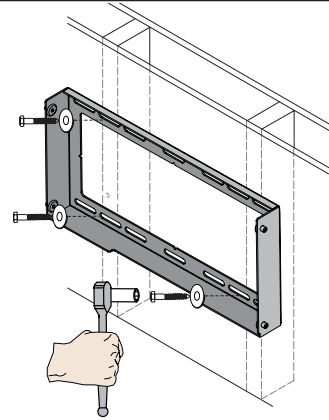

Concrete Installation

 The supplied $\frac{5}{16}$ " concrete wedge anchors must be used for concrete installation.

You will need a $\frac{5}{16}$ " concrete drill bit, which is available at your closest hardware store.

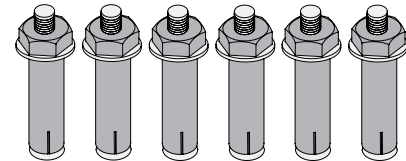

Concrete Wedge Anchors

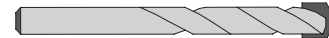

Example of $\frac{5}{16}$ " Concrete Drill Bit (Not Included)

Step 1

 Two people are recommended for this step; one person to level the wall plate and another person to mark the mounting locations.

- 1) Place the wall plate against the wall in the desired viewing location.
- 2) Level the wall plate.
- 3) Use a pencil and mark 2 upper and 2 lower mounting locations where you will be drilling holes for the concrete wedge anchors. Each horizontal location cannot be closer than 12" apart.
- 4) Set the wall plate to one side in a safe location.

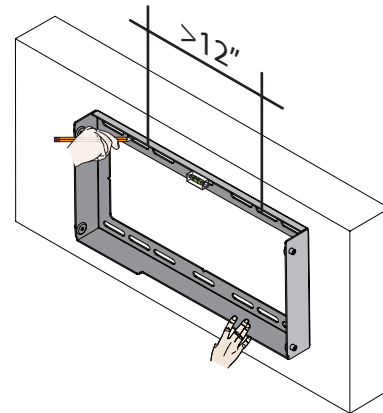

Step 2

Use a power drill and $\frac{5}{16}$ " concrete drill bit to drill a hole at each of the marks.

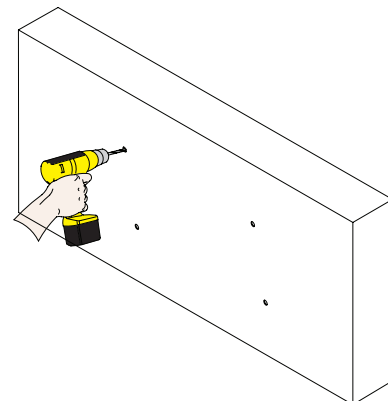



Installing the Wall Plate (cont'd)

Step 3

- 1) Insert a concrete wedge anchor into each hole.
If necessary, lightly tap each concrete wedge anchor into place with a hammer.
- 2) Remove the nuts and washers from all four (4) concrete wedge anchors.
- 3) Replace the washers which you removed from the concrete wedge anchors with the $\frac{5}{16}$ " washers shown in the parts list on Page 3.

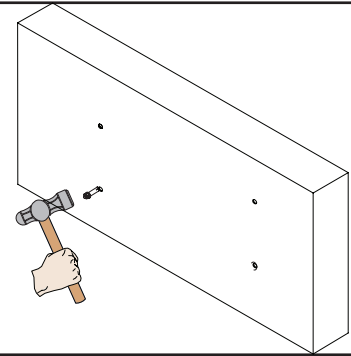

Step 4

- 1) Place the wall plate against the wall over the threaded shafts of the concrete wedge anchors
- 2) Attach the nuts and $\frac{5}{16}$ " washers to each of the concrete wedge anchors and tighten using a socket wrench and an M10 socket.

Do not overtighten the wedge anchor nuts.

Proceed to the "**Mounting Hardware**" section.

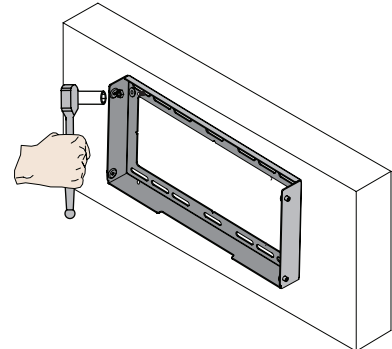

Mounting Hardware

Selecting the Mounting Hardware

- 1) Insert the Thread Depth Indicator into the thread inserts found on the bottom or top of the flat panel.
- 2) Use a pencil to mark the depth of the thread insert on the Thread Depth Indicator, as shown in Figure 1.
- 3) Insert the Thread Depth Indicator into the remaining thread inserts to compare and verify their depth.
- 4) Locate the correct diameter screw for the threaded insert.

If the screw you selected is longer than the mark on the Thread Depth Indicator, as shown in Figure 2 and Figure 3, do not use this screw. The screw length must not bypass the mark.

- 5) Test each size of the screws provided.

The correct screws should thread easily into the mount point and not pull out when tension is applied.

Does your flat panel have:

- Recessed mounting points?
- Uneven mounting points?
- A curved back?
- Any obstruction near the mount point?

If **Yes**, you must install Universal Spacers. Proceed to the "**Universal Spacer Installation**" section.

If **No**, skip to the "**Flat Panel Plate Installation**" section.

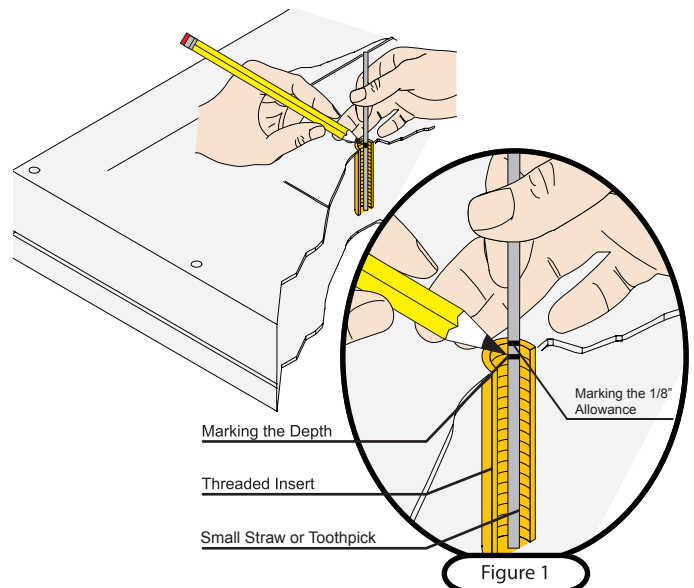

Figure 1

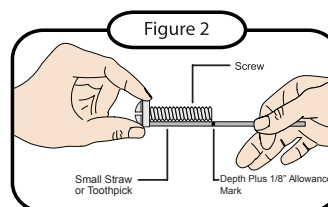

Figure 2

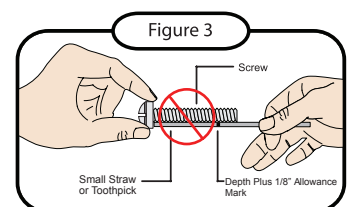



Figure 3



Mounting Hardware (cont'd)

Universal Spacer Installation

Premier Mounts' Universal Spacers allow you to attach the mounting bracket to flat panels which have recessed or uneven mount points. Each Universal Spacer adds 1/4" to the distance between the mounting bracket and your flat panel.

-  The Universal Spacers must be stacked and oriented as shown.
-  The Universal Spacers must only be installed between the mounting bracket and your flat panel.

The Universal Spacers will fit M4, M5, M6 and M8 screw sizes.

Proceed to the "Attaching the Mounting Bracket to the Flat Panel" section.

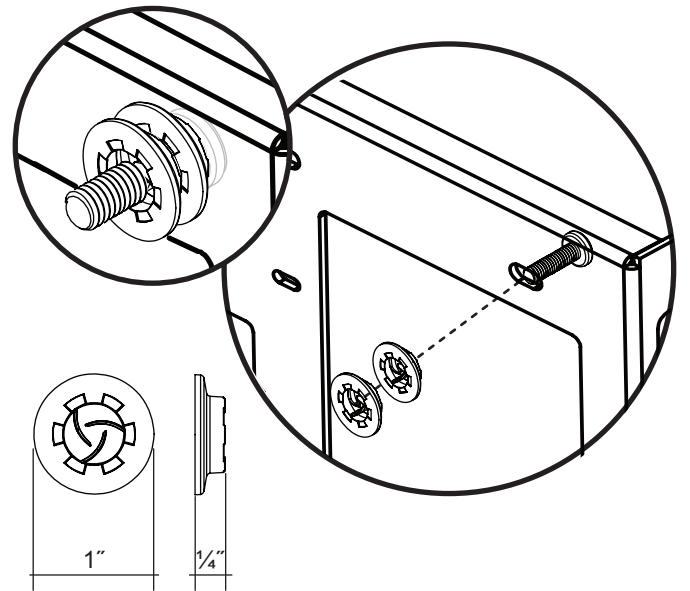

Attaching the Mounting Bracket to the Flat Panel

This section presumes that you have read and understood these sections:

- Selecting the Proper Mounting Hardware
- Universal Spacer Installation



- 1) Place your flat panel screen-side down on a soft, flat surface.
- 2) Identify the number and location of the thread inserts on the back of your flat panel.
- 3) Align the holes on each mounting bracket with the thread inserts on the back of your flat panel.
- 4) Secure the mounting bracket to your flat panel by inserting a minimum of two (4) screws.

-  Do not overtighten the mounting hardware.

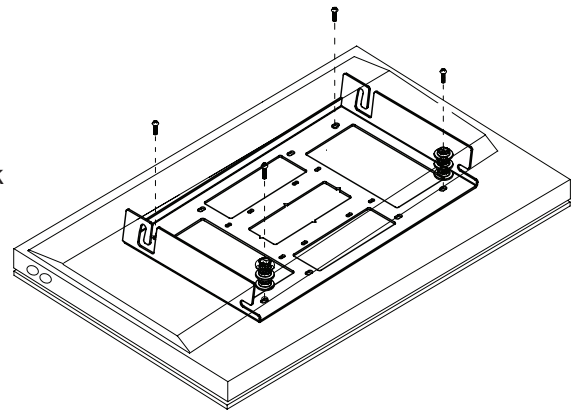
Proceed to the "Attaching the Flat Panel to Back Plate" section.



Attaching the Flat Panel to the Wall Plate

-  This section requires two people.
-  Do not release your flat panel until you are certain that the slots on the upper part of the mounting plate are securely hooked and the bottom slots are resting on in the upper hinge pins of the wall panel.

- 1) Raise the flat panel past the top and bottom hinge pins on the wall plate.
- 2) Slide the flat panel down slowly, keeping it close to the wall.
- 3) Hook the upper mounting slots of the mounting bracket onto the hinge pins of the wall plate so that the top is secure and the bottom slots of the mounting bracket are resting on the lower hinge pins of the wall plate.

-  Make sure the brackets are safely resting on the hinge pins before letting go of the display.

Proceed to the "Securing the GB-VESA42 Mount" section.

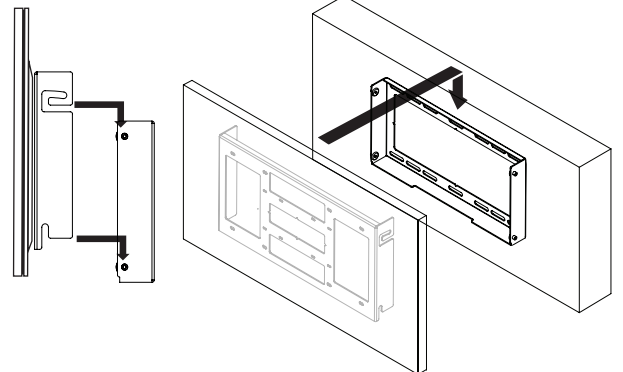



Securing the GB-VESA42 Mount

Secure the mount in place by tightening the (4) M6x12 screws (A) removed at the start of installation.

Do not overtighten the screws.

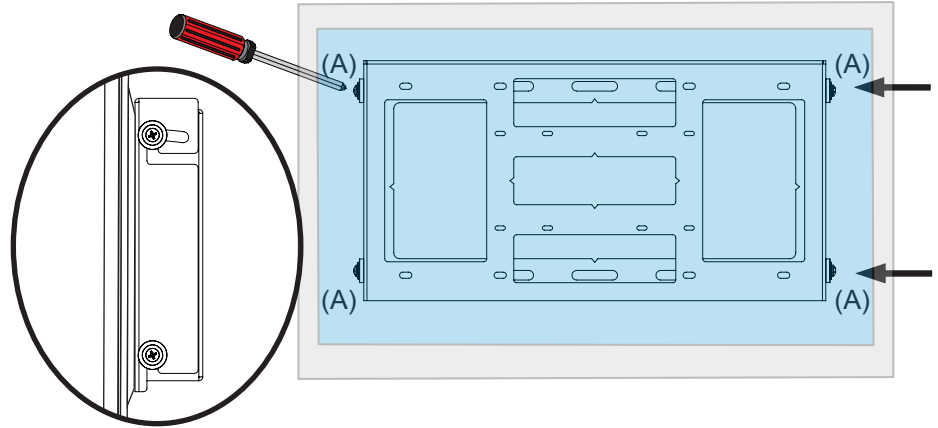

Technical Specifications

All measurements are in inches [millimeters].

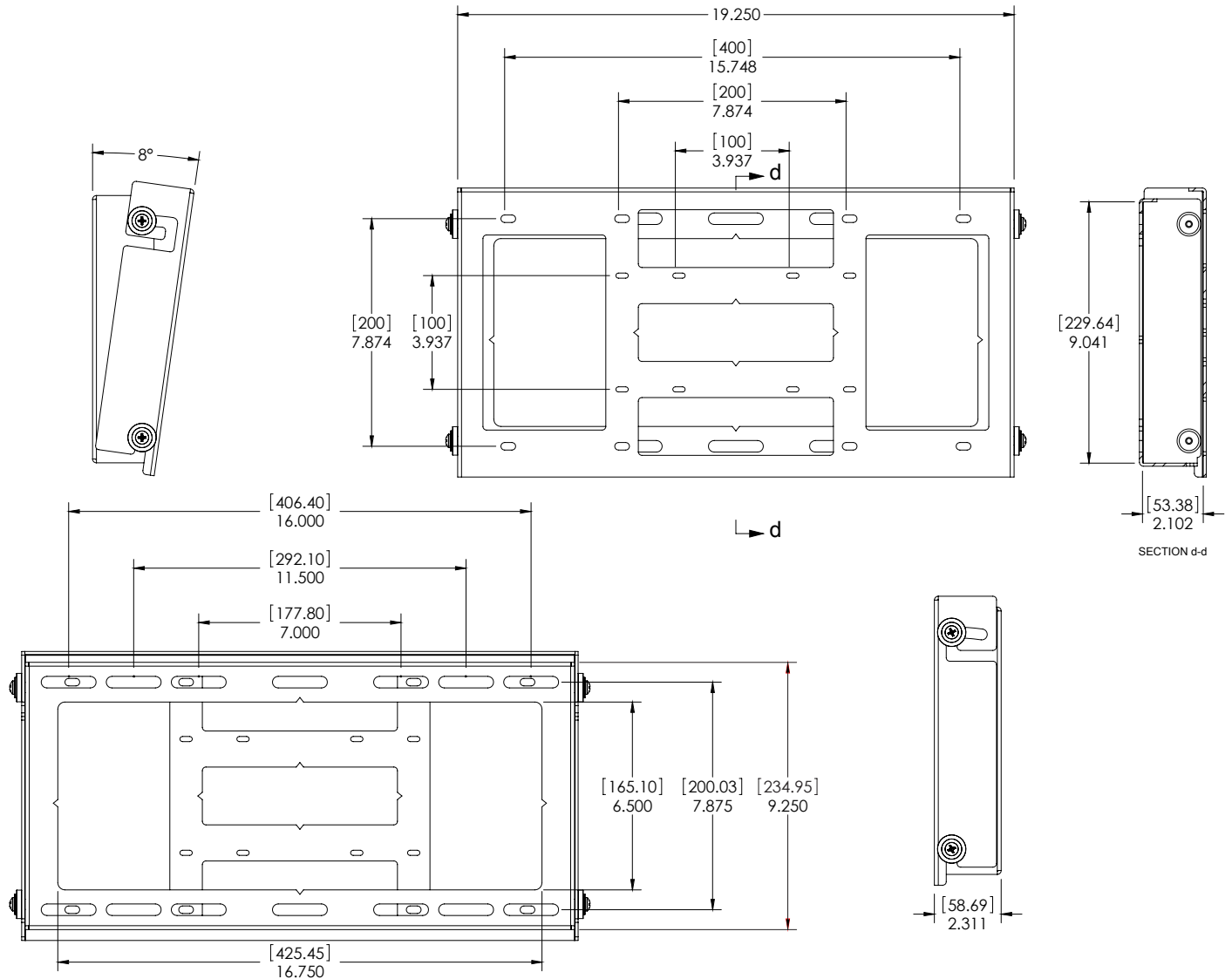



Warranty

PREMIER MOUNTS LIMITED LIFETIME WARRANTY

What and Who is Covered by this Limited Warranty and for How Long

Premier Mounts warrants this product to be free from defects in material and workmanship for the lifetime of the original owner of this product. The limited warranty is valid only for the original purchaser of the product.

What Premier Mounts Will Do

At the sole option of Premier Mounts, Premier Mounts will repair or replace any product or product part that is defective. If Premier Mounts chooses to replace a defective product or part, a replacement product or part will be shipped to you at no charge, but you must pay any labor costs.

What is Not Covered; Limitations

PREMIER MOUNTS DISCLAIMS ANY LIABILITY FOR DAMAGE TO MOUNTS, ADAPTERS, DISPLAYS, PROJECTORS, OTHER PROPERTY, OR PERSONAL INJURY RESULTING, IN WHOLE OR IN PART, FROM IMPROPER INSTALLATION, MODIFICATION, USE OR MISUSE OF ITS PRODUCTS.

PREMIER MOUNTS DISCLAIMS ALL OTHER WARRANTIES, EXPRESS OR IMPLIED, INCLUDING WARRANTIES OF MERCHANTABILITY AND FITNESS FOR A PARTICULAR PURPOSE. PREMIER MOUNTS IS NOT RESPONSIBLE FOR INCIDENTAL OR CONSEQUENTIAL DAMAGES, INCLUDING BUT NOT LIMITED TO, INABILITY TO USE ITS PRODUCTS OR LABOR COSTS FOR REMOVING AND REPLACING DEFECTIVE PRODUCTS OR PARTS. SOME STATES DO NOT ALLOW THE EXCLUSION OR LIMITATION OF INCIDENTAL OR CONSEQUENTIAL DAMAGES, SO THE ABOVE LIMITATION OR EXCLUSION MAY NOT APPLY TO YOU.

What Customers Must Do for Limited Warranty Service

If you discover a problem that you think may be covered by the warranty you MUST REPORT it in writing to the address below within thirty (30) days. Proof of purchase (an original sales receipt) from the original consumer purchaser must accompany all warranty claims. Warranty claims must also include a description of the problem, the purchaser's name, address, and telephone number. General inquiries can be addressed to Premier Mounts Customer Service at 1-800-368-9700. Warranty claims will not be accepted over the phone or by fax.

Premier Mounts
Attn: Warranty Claim
3130 East Miraloma Ave.
Anaheim, CA 92806

How State Law Applies

THIS WARRANTY GIVES YOU SPECIFIC LEGAL RIGHTS, AND YOU MAY ALSO HAVE OTHER RIGHTS WHICH VARY FROM STATE TO STATE.

Disclaimer

Premier Mounts intends to make this manual accurate and complete. However, Premier Mounts makes no claim that the information contained herein covers all details, conditions or variations, nor does it provide for every possible contingency in connection with the installation or use of this product. The information contained in this document is subject to change without notice or obligation of any kind. Premier Mounts makes no representation of warranty, expressed or implied, regarding the information contained herein. Premier Mounts assumes no responsibility for accuracy, completeness or sufficiency of the information contained in this document.