

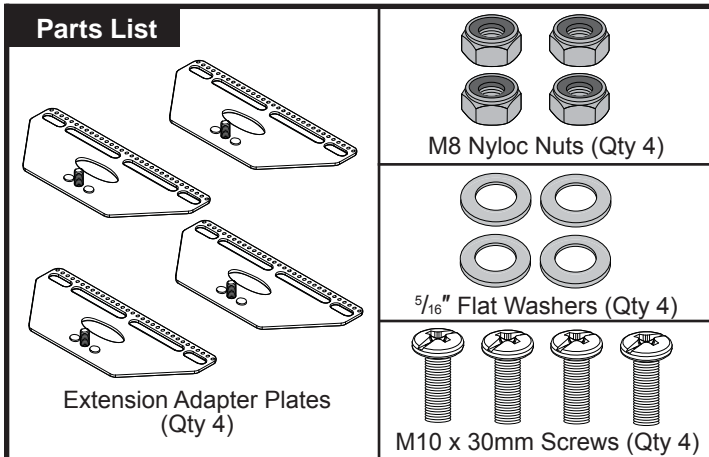

Extension Adapter Plates for 40" to 65" Flat Panels

Model: UFP-1065



 Refer to the following instructions of your specific mount for details on the following:

- Griplate™ Washer Installation
- Universal Spacer Installation

 The extension adapter plates may be used with mounting patterns ranging from 200mm x 200mm to 650mm x 840mm.

Adapter Plate Installation

Step 1

Attach the extension adapter plates to the flat panel using four mounting screws and four (4) Griplate™ washers.

 Do not tighten the mounting hardware at this time.

 If M10 x 30mm mounting screws are needed for your installation, Griplate™ washers cannot be used. Please use the four (4) 5/16" flat washers (supplied) with the M10 x 30mm screws to attach the adapter plates to the flat panel.

Mounting Screw
Griplate™ Washer

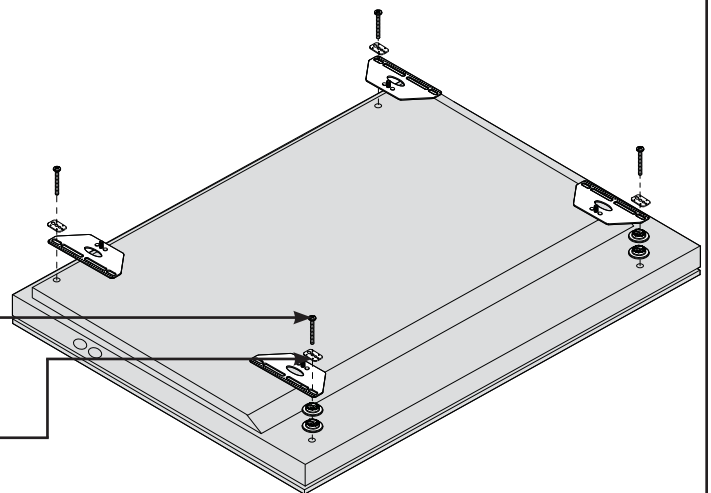

Step 2

- 1) Place the universal bracket arms over the threaded mounting studs that are on the adapter plate.
- 2) Place one (1) 5/16" washer and one (1) M8 nyloc nut on each threaded mount stud.
- 3) Use a socket wrench and 1/2" socket to tighten all M8 nyloc nuts.
- 4) Use a screwdriver and tighten the mounting screws.

 Do not overtighten the mounting screws.

 Make certain that the two alignment stubs on each adapter plate are properly seated in the universal bracket slots. The alignment stubs help keep the universal bracket assembly aligned and level during installation.

