

AM95 Installation Guide

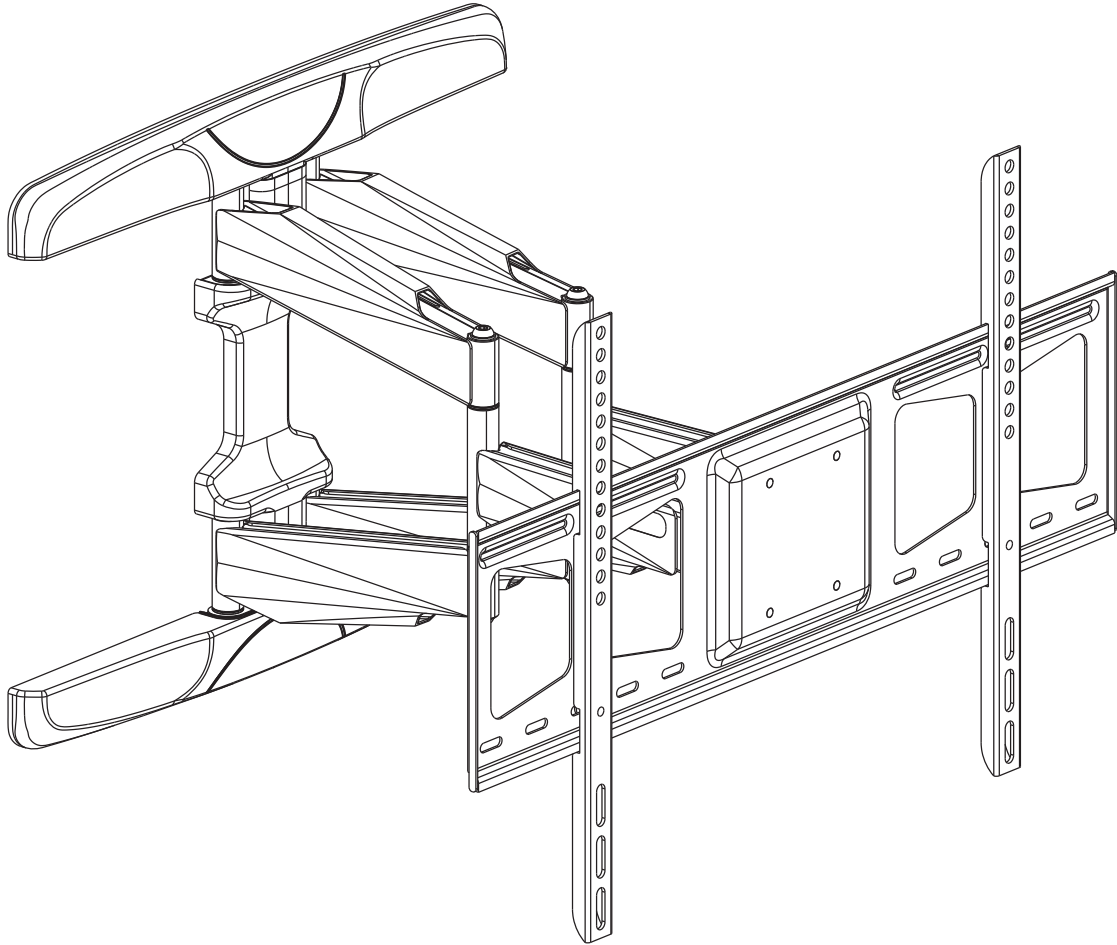

Touchboards

205 Westwood Ave, Long Branch, NJ 07740
Phone: 866-94 BOARDS (26273) / (732)-222-1511
Fax: (732)-222-7088 | E-mail: sales@touchboards.com

 **PREMIER
MOUNTS**

YOUR TRUSTED ADVISOR IN AV MOUNTING SOLUTIONS

www.premiermounts.com | North America 800.368.9700 | International +1-714-632-7100
1321 S. State College Blvd., Fullerton, CA 92831 USA

AM95 Installation Guide

Included Components:

Maximum Flat Panel Weight:
95 lb. / 43.1 kg.

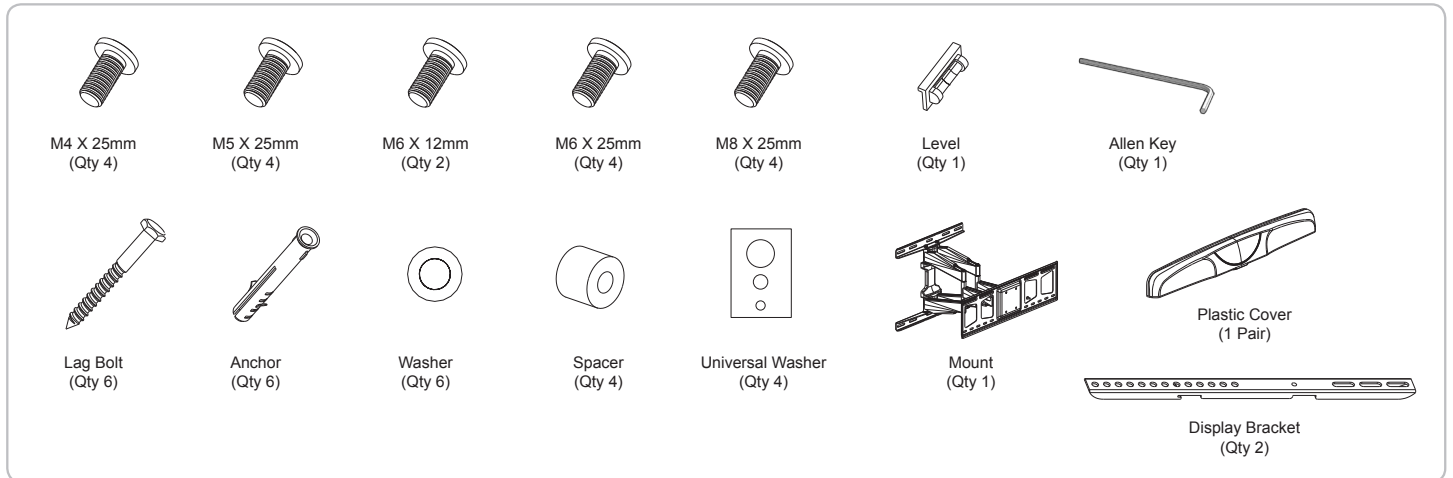

1A

Solid Concrete Mounting

- 1) Place the Mount on the wall and level the mount.
- 2) Mark the six (6) mounting locations using a pencil.
- 3) Drill six (6) marking locations using the appropriate masonry drill bit and drill gun.
- 4) Lightly tap the six (6) concrete anchors into the holes.
- 5) Install the six (6) lag bolts and washers into the anchor to secure the mount to the wall.



Do not over tighten the lag bolts.

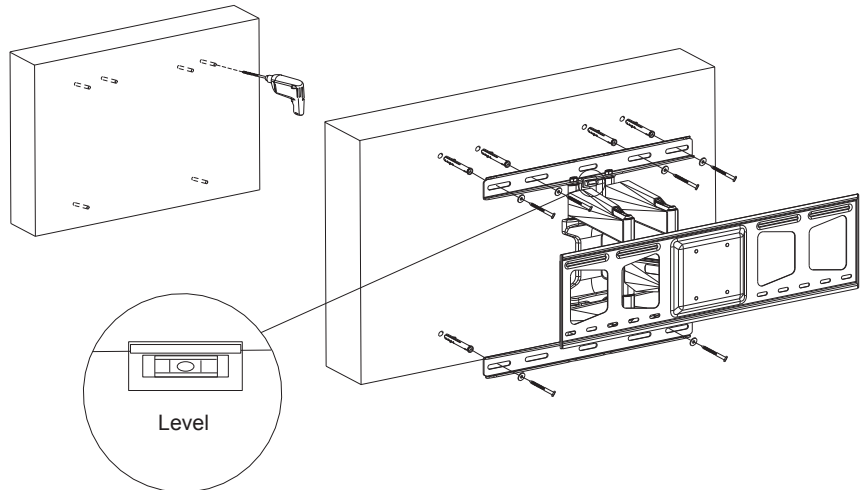

1B

Wood Stud Mounting

- 1) Use a stud finder to find the wood stud behind the wall.
- 2) With a pencil mark the wood stud locations.
- 3) Place the mount over the wood stud locations and mark four (4) mounting locations.
- 4) Drill four (4) holes on the marking locations using a drill bit and a drill gun.
- 5) Install the mount to the wall using four (4) lag bolts and washers.



Do not over tighten the lag bolts.

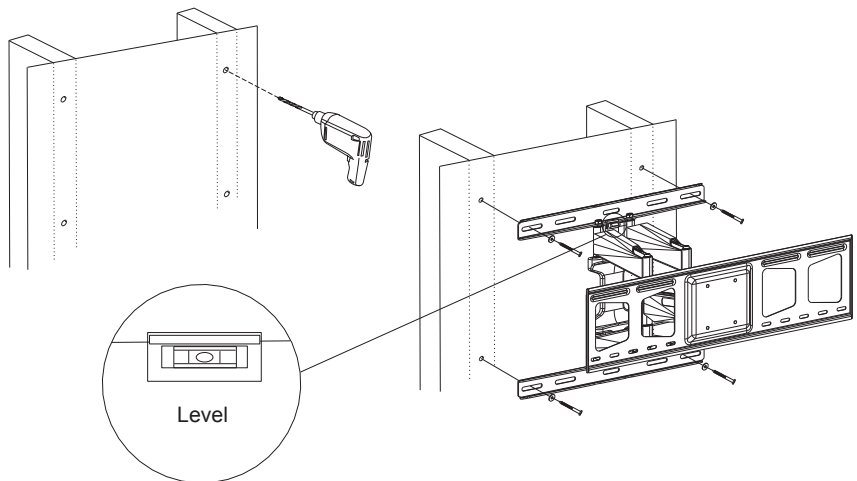

2A

Attaching the Display Brackets

For display's with a flat back

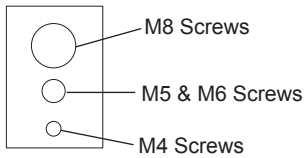

Install the display brackets to the display using four (4) universal washers and four (4) M4, M5, M6 or M8 screws depending on the display.

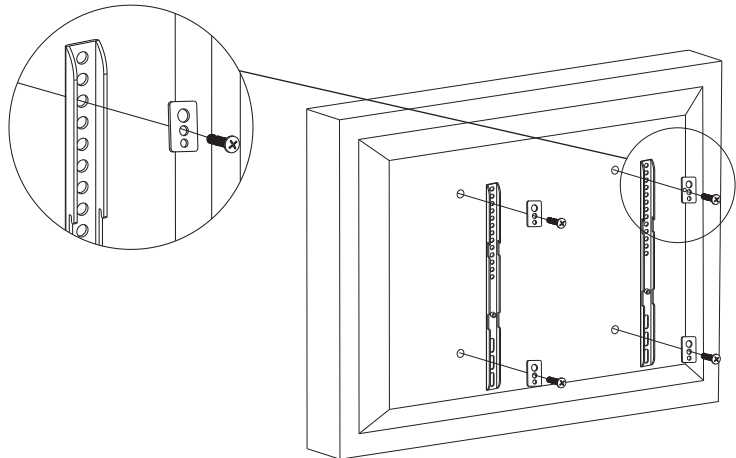

2B

Attaching the Display Brackets

For display's with a curved back or obstruction

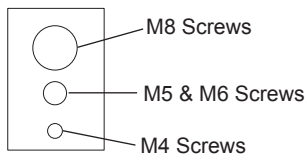

Install the display brackets to the display using four (4) universal washers and four (4) spacers and four (4) M4, M5, M6 or M8 screws depending on the display.

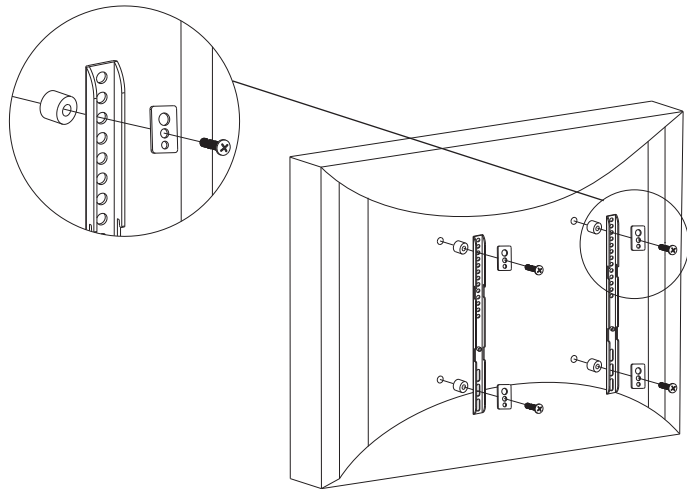

3

Install the plastic covers to the mount.

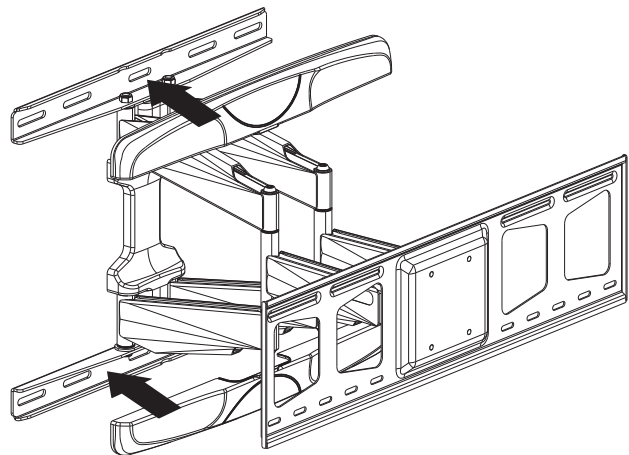

AM95

Installation Guide

4

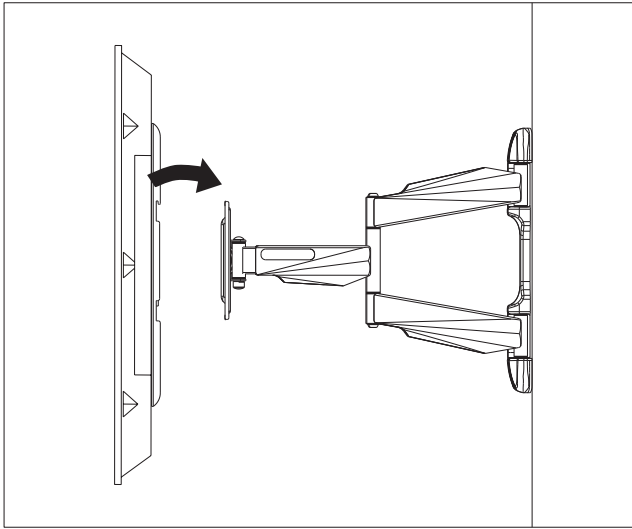

Hang the display to the mount.

5

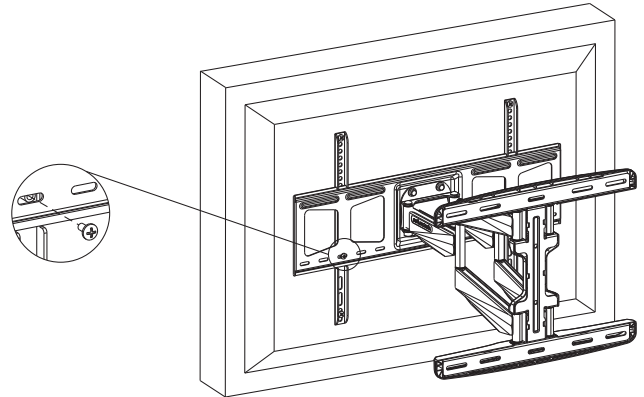

Install the two (2) M6 x 12mm safety screws to the brackets.

6

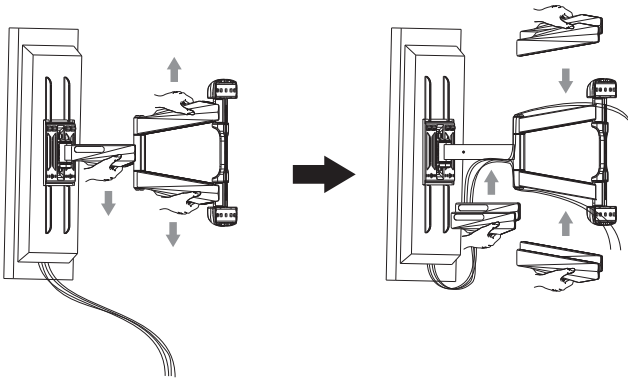

Cable Management

Cable management clips
Cable routing access points

7

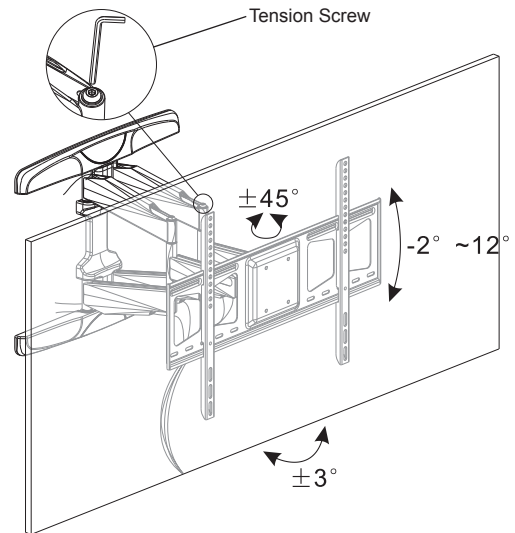

Use the supplied Allen key to tighten or loosen the tension screw.

PREMIER MOUNTS
LIMITED LIFETIME WARRANTY

What and Who is Covered by this Limited Lifetime Warranty

Premier Mounts warrants all mounting products to be free from defects in material and workmanship for the lifetime of the original installation of the product.

What Premier Mounts Will Do

At the sole option of Premier Mounts, Premier Mounts will repair or replace any product or product part that is defective. If Premier Mounts chooses to replace a defective product or part, a replacement product or part will be shipped to you at no charge, but you must pay any related labor costs.

What is Not Covered: Limitations

Premier Mounts disclaims any liability for damage to mounts, adapters, displays, projectors, other property, or personal injury resulting, in whole or in part, from improper installation, modification, use or misuse of its products.

NOTWITHSTANDING ANYTHING TO THE CONTRARY IN THIS WARRANTY, THIS WARRANTY IS LIMITED TO FIVE YEARS FROM THE DATE OF PURCHASE IN THE EVENT THAT THE WARRANTED PRODUCT IS COMMERCIALY RENTED OUT.

Electrical products and components, such as amplifiers, speakers, motors, switches remote controls and related electrical items, are backed by a 3-year warranty.

Premier Mounts disclaims all other warranties, express or implied, including warranties of merchantability and fitness for a particular purpose. Premier Mounts is not responsible for incidental or consequential damages, including but not limited to, inability to use its products or labor costs for removing and replacing defective products or parts. Some states do not allow the exclusion or limitation of incidental or consequential damages, so the above limitation or exclusion may not apply to you.

What Customers Must Do for Warranty Service

If you discover a problem that you think may be covered by the warranty, you must report it in writing to the address below within thirty (30) days. Proof of purchase (an original sales receipt) from the original consumer purchaser must accompany all warranty claims. Warranty claims must also include a description of the problem, the purchaser's name, address, and telephone number. General inquiries can be addressed to Premier Mounts Customer Service at 1-800-368-9700. Warranty claims will not be accepted over the phone or by fax.

Premier Mounts
Attn: Warranty Claim
1321 S. State College Blvd.
Fullerton, CA 92831 USA

How State Law Applies

This warranty gives you specific legal rights, and you may also have other rights which vary from state to state.

Premier Mounts intends to make this manual accurate and complete. However, Premier Mounts makes no claim that the information contained herein covers all details, conditions or variations, nor does it provide for every possible contingency in connection with the installation or use of this product. The information contained in this document is subject to change without notice or obligation of any kind. Premier Mounts makes no representation of warranty, expressed or implied, regarding the information contained herein. Premier Mounts assumes no responsibility for accuracy, completeness or sufficiency of the information contained in this document.

