

Model: **ECM-3763S,
ECM-3763D**

Weight Capacity: 175 lb./79.5 kg Per Head

Features

- 1** Mount displays right out of the box with no adapters needed
 - 2** Works with optional brackets for mini PCs and digital media player adapters
 - 3** Integrated cable management keeps installation clean and organized
- 15° tilt available for both models
 - ECM-3763S supports a single flat panel and suspends from the ceiling with 1.5 in. NPT pipe (not included)
 - ECM-3763D supports two flat panels back-to-back and suspends from the ceiling with 2 in. NPT pipe (not included)
 - ECM-3763D center support features mounting points to receive J-Box for power or A/V (not included)

The ECM Ceiling Mount Series features single & back-to-back flat panel mounts that hold displays up to 175 lb./79.5 kg per head. The ECM-3763S suspends a single display from the ceiling and adapts to 1.5 in. NPT threaded pipe or height adjustable pipe adapter. The ECM-3763D suspends two back-to-back displays from the ceiling and adapts to 2 in. NPT pipe. Both models mount displays right out of the box with no adapters needed, work with optional brackets for mini PCs or digital media player adapters, and offer integrated cable management for a clean and organized installation.



Touchboards
 205 Westwood Ave, Long Branch, NJ 07740
 Phone: 866-94 BOARDS (26273) / (732)-222-1511
 Fax: (732)-222-7088 | E-mail: sales@touchboards.com

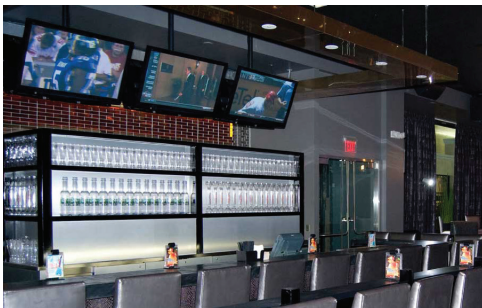

ECM-3763S supports a single flat panel up to 175 lb. ECM-3763D supports two flat-panels up to 350 lb. total



ECM-3763D center support features mounting points to receive J-Box for power or A/V (not included)

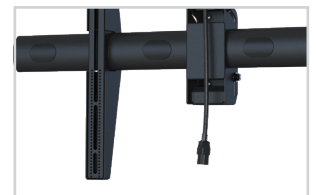

Both mounts feature integrated cable management for a clean, organized look

ECM Ceiling Mount Series for Single & Back-to-Back Flat Panels

ECM-3763S, ECM-3763D

Specifications



Color	Weight	Weight Capacity / Mount	Mounting Pattern
ECM-3763S Black	24.44 lb. 11.1 kg	175 lb. 79.5 kg	200 x 200 mm (Min) - 875 x 505 mm (Max)
ECM-3763D Black	53 lb. 24.1 kg	175 lb. 79.5 kg	200 x 200 mm (Min) - 875 x 505 mm (Max)
Width x Height x Depth		Total Weight Capacity	Warranty
ECM-3763S	37.2 x 21.32 x 3.34 in. 945 x 541 x 85 mm	175 lb. 79.5 kg	Lifetime
ECM-3763D	37.2 x 21.32 x 10.19 in. 945 x 541 x 259 mm	350 lb. 159.1 kg	Lifetime

Packaging

Width x Height x Depth
ECM-3763S 42.75 x 13.38 x 3.5 in. 1086 x 340 x 89 mm
ECM-3763D (Box 1) 42.75 x 13.38 x 3.5 in. 1086 x 340 x 89 mm
ECM-3763D (Box 2) 42.75 x 13.38 x 3.5 in. 1086 x 340 x 89 mm

Contents
ECM-3763S: ECM Molding Covers (x2), Weldment Support Bracket (x2), ECM Mount Assembly (x1), Hardware Pack (x1)
ECM-3763D (2 Boxes): ECM Molding Covers (x4), Weldment Support Bracket (x4), ECM Mount Assembly without Coupler (x2), Hardware Pack (x2), Dual Mount CRM Back-to-Back Assembly (x1)

Accessories

 <p>Adjustable-Height Ceiling Adapter (ECM3763S only) AST-2446</p>	 <p>Adjustable-Height Ceiling Adapter (ECM3763D only) AST-2446-2</p>
--	---

Architectural Drawing

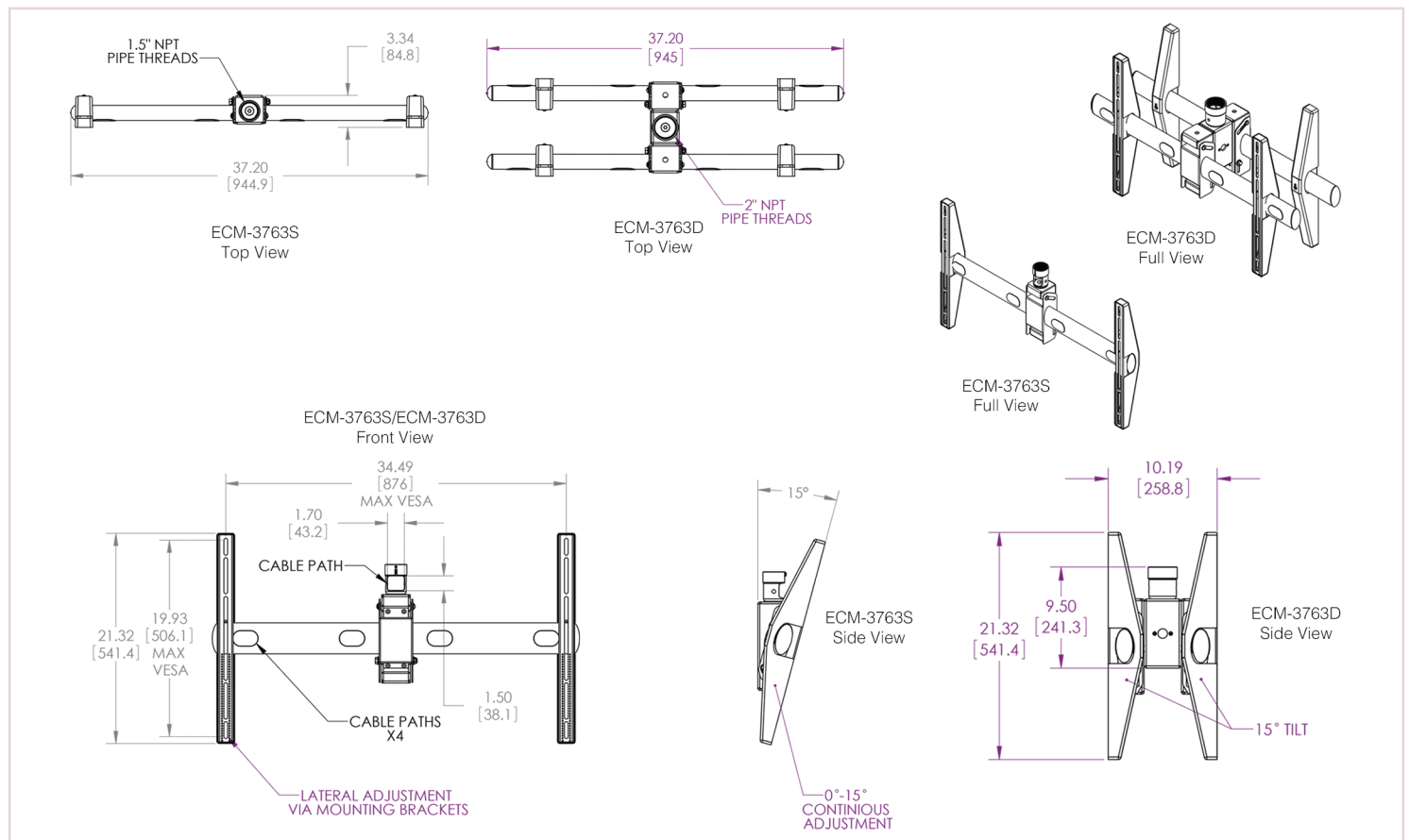

Specifications subject to change without notice

T: 800.368.9700 Int'l: +001.714.632.7100 | www.mounts.com | 1321 S. State College Blvd., Fullerton, CA 92831 USA



Visit mounts.com to see the complete line of AV solutions from Premier Mounts, including flat-panel mounts, projector mounts, carts/stands, and a full assortment of accessories.
© 2015 Premier Mounts. All rights reserved.

Rev. 03-15-09