

Installation Instructions

Introduction

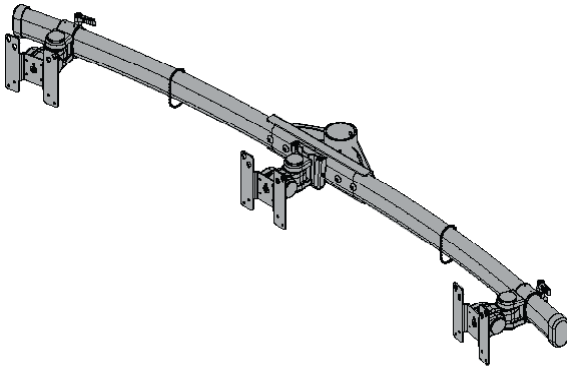

The MM-CB3 is a triple multimonitor mount arm that works with any 2" tubing. Each mounting head provides 90° of omnidirectional tilt. The mounting heads include both 75x75mm and 100x100mm VESA mounting patterns. The arm includes integrated cable management tabs to keep wires and cables protected and organized. The mounting heads can be horizontally adjusted.

Step 1

- 1) Slide your mounting arm adapter bracket over the pole and base (Figure 1) (not included, but should be previously installed).

? Determine the position on the pole desired for your mounting arm.

- 2) Tighten the two (2) pre-installed M8 x 6mm set screws in the back of the MM-CB3 adapter bracket. Tighten with included allen key when in desired position.

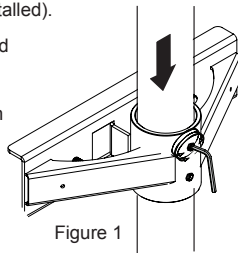

Figure 1

Step 2

- 1) Slide the left mounting head over the left arm until it is in the desired position (Figure 2). Repeat for the right mounting head.

! The center mounting head will be installed in a later step.

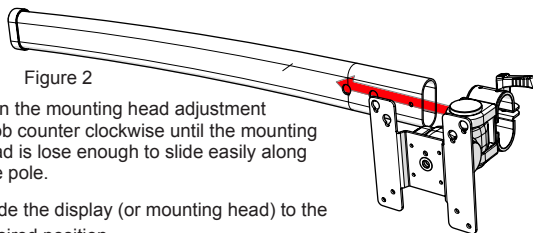
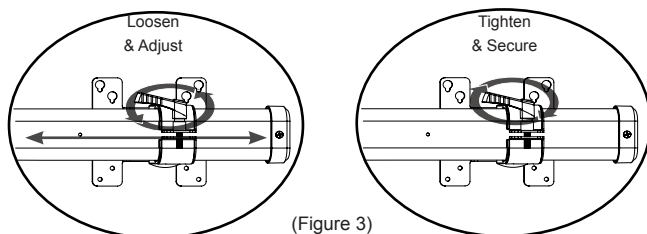

Figure 2

- 2) Turn the mounting head adjustment knob counter clockwise until the mounting head is loose enough to slide easily along the pole.
3. Slide the display (or mounting head) to the desired position.
4. When in place, turn the adjustment head clockwise to tighten it. Make sure it is completely secure and does not move before you move on to the next display or finish (Figure 3).
5. Repeat steps for other displays if desired.



(Figure 3)

Parts List

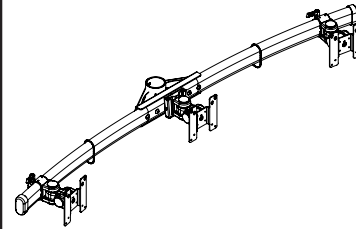

MM-CB3
 Triple Multi Monitor Mounting Arm
 (Qty 1)



M6 x 8 Truss Head Screws
 (Qty 2)

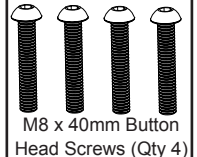

M8 x 40mm Button Head Screws
 (Qty 4)

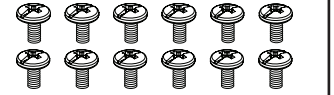

M4 x 10mm Combo Screws
 (Qty 12)

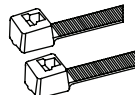

4" Cable Ties
 (Qty 2)



Socket Wrench
 (Qty 1)



6mm Allen Key
 (Qty 1)



5/32" Allen Key
 (Qty 1)

Step 3

- 1) Slide one arm (with now installed mounting head) back into the pre-installed arm adapter bracket.
- 2) Once the arm is lined up with the holes in the arm adapter bracket, insert two (2) M8 x 40mm button head screws per arm (Figure 4)
- 3) Use the 6mm allen key to tighten the screws.



Do not overtighten the mounting hardware

- 4) Repeat step for the second arm.

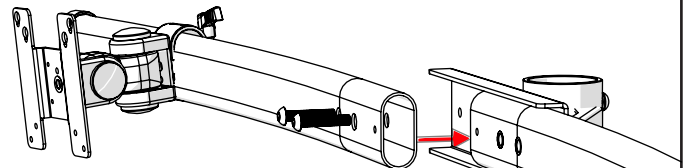

(Figure 4)

Step 4

- 1) Install the center head bracket by aligning the screw holes with those in the center where the two previously installed arms come together (Figure 5)
- 2) Use the two (2) M6 x 8 Truss Head Screws to attach the bracket to the mounting arms.



Do not overtighten the mounting hardware

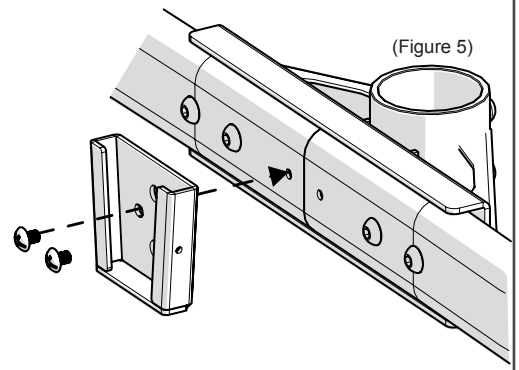

(Figure 5)

Step 5

- 1) Slide the center mounting head down into the center head bracket until the head rests on the bottom of the bracket (Figure 6).

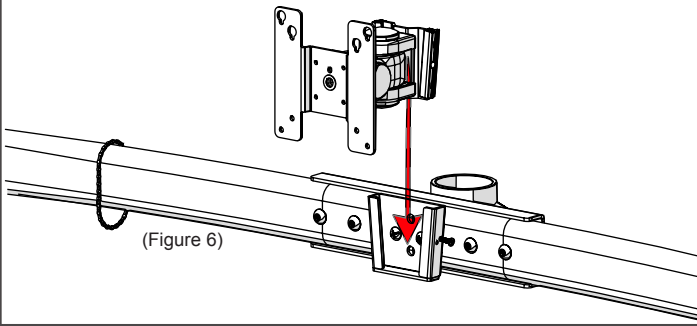

Step 6

- 1) Tighten the two (2) pre-installed M4 x 12mm screws in each side of the center adapter bracket through the mounting head (Figure 7).
- 2) Do not overtighten the mounting hardware

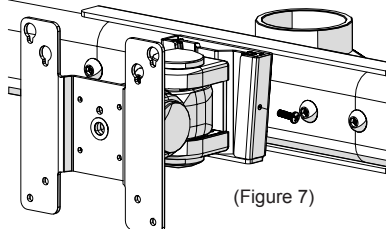

Step 7



Are you installing to a 75x75mm or 100x100mm VESA mounting pattern?

For 75x75mm, use mounting points A. For 100x100mm use points B in Figure 8.

- 1) Thread the M4 screws to one-half of their length into the top two mounting holes on each display, but do not tighten the M4 screws at this time.

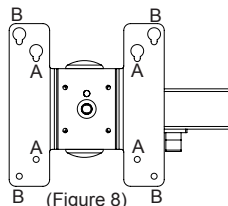

Step 8

- 1) Insert the heads of the M4 screws through the keyhole slots on the mounting head (Figure 5).
- 2) Insert the remaining two (2) M4x10mm screws, into the bottom mounting points (Figure 4)
- 3) Repeat sub-steps 1 & 2 for the second & third display.
- 4) Tighten all M4 screws.



Do not overtighten the mounting hardware

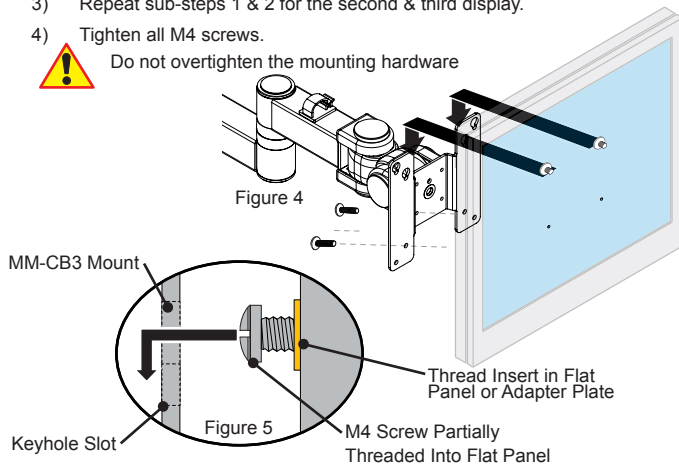

Step 9

To adjust the tension and/or tilt angle of the mounting head:

- 1) Adjust the mounting head by utilizing the 90° continuous tilt, until it is in the desired position.
- 2) Remove the side and bottom cosmetic cap from the mounting head (Figure 6)
- 3) Use the supplied socket wrench to tighten both nuts.
- 4) The side nut secures the tilt position (Point A), while the bottom nut secures the pivot (Point B).



Do not overtighten the mounting hardware

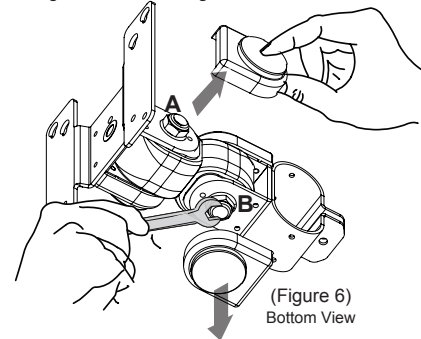

PREMIER MOUNTS

LIMITED LIFETIME WARRANTY

What and Who is Covered by this Limited Warranty and for How Long

Premier Mounts warrants this product to be free from defects in material and workmanship for the lifetime of the original owner of this product. The limited warranty is valid only for the original purchaser of the product.

What Premier Mounts Will Do

At the sole option of Premier Mounts, Premier Mounts will repair or replace any product or product part that is defective. If Premier Mounts chooses to replace a defective product or part, a replacement product or part will be shipped to you at no charge, but you must pay any labor costs.

What is Not Covered; Limitations

PREMIER MOUNTS DISCLAIMS ANY LIABILITY FOR DAMAGE TO MOUNTS, ADAPTERS, DISPLAYS, PROJECTORS, OTHER PROPERTY, OR PERSONAL INJURY RESULTING, IN WHOLE OR IN PART, FROM IMPROPER INSTALLATION, MODIFICATION, USE OR MISUSE OF ITS PRODUCTS. PREMIER MOUNTS DISCLAIMS ALL OTHER WARRANTIES, EXPRESS OR IMPLIED, INCLUDING WARRANTIES OF MERCHANTABILITY AND FITNESS FOR A PARTICULAR PURPOSE. PREMIER MOUNTS IS NOT RESPONSIBLE FOR INCIDENTAL OR CONSEQUENTIAL DAMAGES, INCLUDING BUT NOT LIMITED TO, INABILITY TO USE ITS PRODUCTS OR LABOR COSTS FOR REMOVING AND REPLACING DEFECTIVE PRODUCTS OR PARTS. SOME STATES DO NOT ALLOW THE EXCLUSION OR LIMITATION OF INCIDENTAL OR CONSEQUENTIAL DAMAGES, SO THE ABOVE LIMITATION OR EXCLUSION MAY NOT APPLY TO YOU.

What Customers Must Do for Limited Warranty Service

If you discover a problem that you think may be covered by the warranty you MUST REPORT it in writing to the address below within thirty (30) days. Proof of purchase (an original sales receipt) from the original consumer purchaser must accompany all warranty claims. Warranty claims must also include a description of the problem, the purchaser's name, address, and telephone number. General inquiries can be addressed to Premier Mounts Customer Service at 1-800-368-9700. Warranty claims will not be accepted over the phone or by fax.

Premier Mounts
Attn: Warranty Claim
3130 East Miraloma Ave.
Anaheim, CA 92806

How State Law Applies

THIS WARRANTY GIVES YOU SPECIFIC LEGAL RIGHTS, AND YOU MAY ALSO HAVE OTHER RIGHTS WHICH VARY FROM STATE TO STATE.