

INSTALLATION INSTRUCTIONS

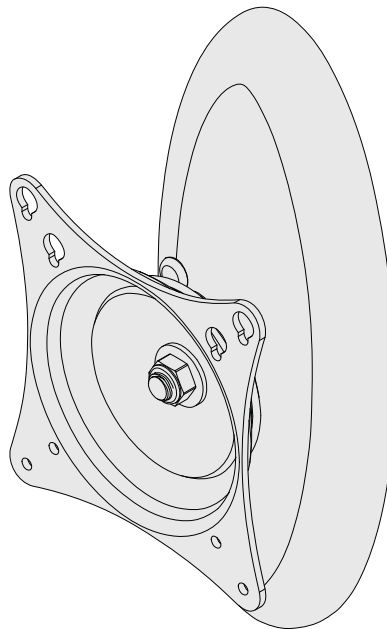

205 Westwood Ave, Long Branch, NJ 07740
Phone: 866-94 BOARDS (26273) / (732)-222-1511
Fax: (732)-222-7088 | E-mail: sales@touchboards.com



PTM / PTM-B
Tilt/Pivot Mount

NORTH AMERICA

3130 East Miraloma Avenue
Anaheim, CA 92806 USA
USA and Canada
Phone: 1.800.368.9700
Fax: 1.800.832.4888
Other Locations
Phone: (001).714.632.7100
Fax: (001).714.632.1044

EUROPE

Swallow House,
Shilton Industrial Estate,
Shilton, Coventry, England CV79JY
Phone: +44 (0) 2476 614700
Fax: +44 (0) 2476 614710



Contents

Weight Limit.....	2
Warning Statements.....	2
Installation Tools.....	3
Parts List.....	3
Mounting Hardware.....	4
Features.....	5
Installing the Wall Plate.....	6
Determining the Mounting Surface.....	6
Wood Stud Installation.....	6
Concrete Installation.....	7
Mounting Hardware.....	9
Selecting the Mounting Hardware.....	9
Universal Spacer Installation.....	10
UFP-280 Adapter Plate Installation.....	10
Attaching the Flat Panel to the Mount.....	11
Attaching the Mount to the Wall Plate.....	11
Securing the Mount.....	12
Adjusting the Mount Tension.....	12
Removing the Mount.....	12
Adjusting the Tension.....	12
Replacing the Mount.....	12
Technical Specifications.....	13
Warranty.....	14

Weight Limit

Maximum Flat Panel Weight: **50 lbs.**

THE WALL STRUCTURE MUST BE CAPABLE OF SUPPORTING AT LEAST FIVE TIMES THE WEIGHT OF THE FLAT PANEL. IF NOT, THE WALL STRUCTURE MUST BE REINFORCED.







Warning Statements

 PRIOR TO THE INSTALLATION OF THIS PRODUCT, THE INSTALLATION INSTRUCTIONS MUST BE READ AND COMPLETELY UNDERSTOOD. KEEP THESE INSTALLATION INSTRUCTIONS IN AN EASILY ACCESSIBLE LOCATION FOR FUTURE REFERENCE.

 PROPER INSTALLATION PROCEDURE BY A QUALIFIED SERVICE TECHNICIAN MUST BE FOLLOWED, AS OUTLINED IN THESE INSTALLATION INSTRUCTIONS. FAILURE TO DO SO COULD RESULT IN PROPERTY DAMAGE, SERIOUS PERSONAL INJURY, OR EVEN DEATH.

 SAFETY MEASURES MUST BE PRACTICED AT ALL TIMES DURING THE ASSEMBLY OF THIS PRODUCT. USE PROPER SAFETY EQUIPMENT AND TOOLS FOR THE ASSEMBLY PROCEDURE TO PREVENT PERSONAL INJURY.

 PREMIER MOUNTS DOES NOT WARRANT AGAINST DAMAGE CAUSED BY THE USE OF ANY PREMIER MOUNTS PRODUCT FOR PURPOSES OTHER THAN THOSE FOR WHICH IT WAS DESIGNED OR DAMAGE CAUSED BY UNAUTHORIZED ATTACHMENTS OR MODIFICATIONS, AND IS NOT RESPONSIBLE FOR ANY DAMAGES, CLAIMS, DEMANDS, SUITS, ACTIONS OR CAUSES OF ACTION OF WHATEVER KIND RESULTING FROM, ARISING OUT OF OR IN ANY MANNER RELATING TO ANY SUCH USE, ATTACHMENTS OR MODIFICATIONS.

-  At least two qualified people should perform the assembly procedure. Personal injury and/or property damage can result from dropping or mishandling the flat panel.
-  If mounting to wall studs or ceiling studs, make sure that the mounting screws are anchored into the center of the wall studs or ceiling studs. Use of an edge-to-edge stud finder is recommended.
-  It is recommended that a maximum of 5/8" plaster board be used when mounting to wooden studs.
-  Be aware of the mounting environment. If drilling and/or cutting into the mounting surface, always make sure that there are no electrical wires in wall. Cutting or drilling into an electrical line may cause serious personal injury.
-  Make sure there are no water or natural gas lines inside the wall where the mount is to be located. Cutting or drilling into a water or gas line may cause severe property damage or personal injury.
-  This product is intended for indoor use only. Use of this product outdoors could lead to product failure and/or serious personal injury.
-  Do not install near sources of high heat. Do not install on a structure that is prone to vibration, movement or chance of impact.









Contact Premier Mounts with any questions:
(800) 368-9700
techsupport@mounts.com

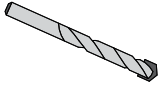
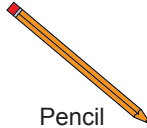
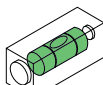
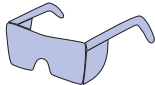
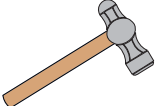

Installation Tools

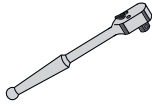
The following tools may be required, dependent upon your particular installation. These tools are not provided by Premier Mounts, but you can purchase them at your local hardware store.

 Electronic Stud Finder	 Hand Held Drill	 1/8" Wood Drill Bit	 5/16" Concrete Drill Bit**	 Pencil	 Level
 Protective Eyewear	 Hammer**	 Tape Measure	 Phillips Tip Screwdriver	 Socket Wrench	 1/2" Socket**

** Optional tools for concrete / steel stud installations.

Parts List



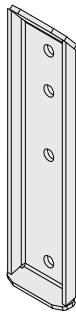
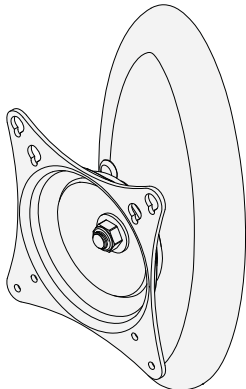
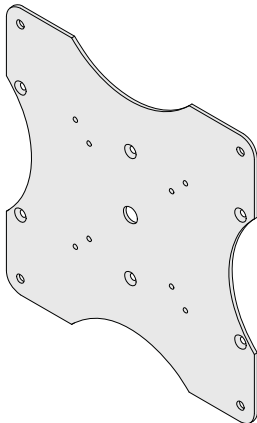
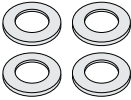
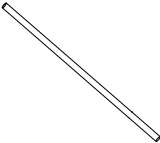
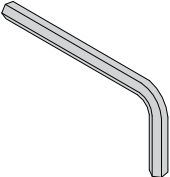
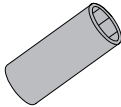
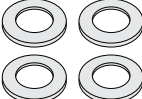
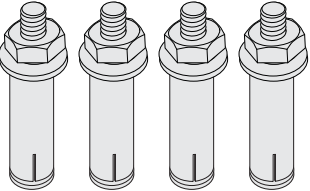
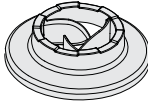
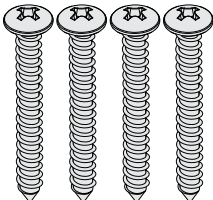

Your Premier Mounts product is shipped with all proper installation hardware and components. Make sure that none of these parts are missing and/or damaged before beginning installation. If there are parts missing and/or damaged, please stop the installation and contact Premier Mounts (800) 368-9700.

PTM Tilt/Pivot Mount Components			
 Wall Plate (Qty 1)	 Tilt/Pivot Mount (Qty 1)	 UFP-280 Adapter Plate (Qty 1)	
 M4 Flat Washers (Qty 4)	 Thread Depth Indicator (Qty 1)	 M3 Allen Wrench (Qty 1)	 14mm Socket (Qty 1)
 M5 Flat Washers (Qty 4)			
 5/16" Concrete Wedge Anchors (Qty 4)	 Universal Spacers (Qty 30)	 #14 x 2" Wood Screws (Qty 4)	

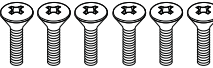
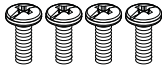
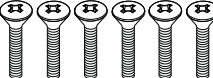
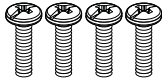
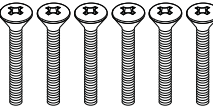
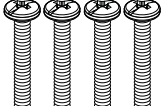
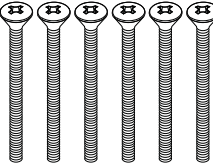
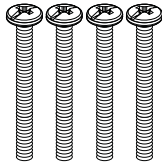

Parts List (cont'd)

Mounting Hardware

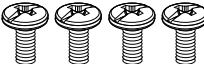
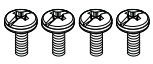
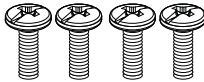
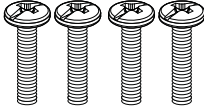
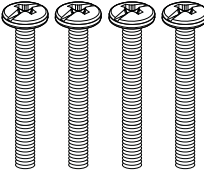
<p>M4 x 10mm Flat Head Screw (Qty 6)</p> 	<p>M5 x 10mm Screw (Qty 4)</p> 
<p>M4 x 16mm Flat Head Screw (Qty 6)</p> 	<p>M5 x 16mm Screw (Qty 4)</p> 
<p>M4 x 20mm Flat Head Screw (Qty 6)</p> 	<p>M5 x 20mm Screw (Qty 4)</p> 
<p>M4 x 30mm Flat Head Screw (Qty 6)</p> 	<p>M5 x 30mm Screw (Qty 4)</p> 
<p>M4 x 45mm Flat Head Screw (Qty 6)</p> 	<p>M5 x 45mm Screw (Qty 4)</p> 
<p>M6 x 10mm Screw (Qty 4)</p> 	<p>M4 x 5mm Screw (Qty 4)</p> 
<p>M6 x 16mm Screw (Qty 4)</p> 	<p>M4 x 10mm Screw (Qty 4)</p> 
<p>M6 x 20mm Screw (Qty 4)</p> 	
<p>M6 x 30mm Screw (Qty 4)</p> 	
<p>M6 x 45mm Screw (Qty 4)</p> 	



Features

Dynamic Viewing

360° rotation and 15° of tilt allow for excellent viewing of your flat panel.

Adjustable Tension

Stays where you want it regardless of flat panel size or weight.

Stylish Design

Sleek and unobtrusive, yet supremely sturdy.

Robust Mount Design

The heavy duty wall plate ensures that your flat panel stays where you installed it.

Smooth Function

Exclusive Radial Glide Technology™ for effortless motion.

Low Profile

Less than 3" from the wall.

Universal Spacers

Premier Mount's uniquely designed spacers that fit multiple screw sizes, and work with either the PTM mount or the UFP-280 Adapter Plate.

Versatile Mounting Points

The PTM mount, in concert with the UFP-280, provides mounting points for 75mm x 75mm VESA and 100mm x 100mm VESA, as well as 200mm x 100mm and 200mm x 200mm mount configurations.

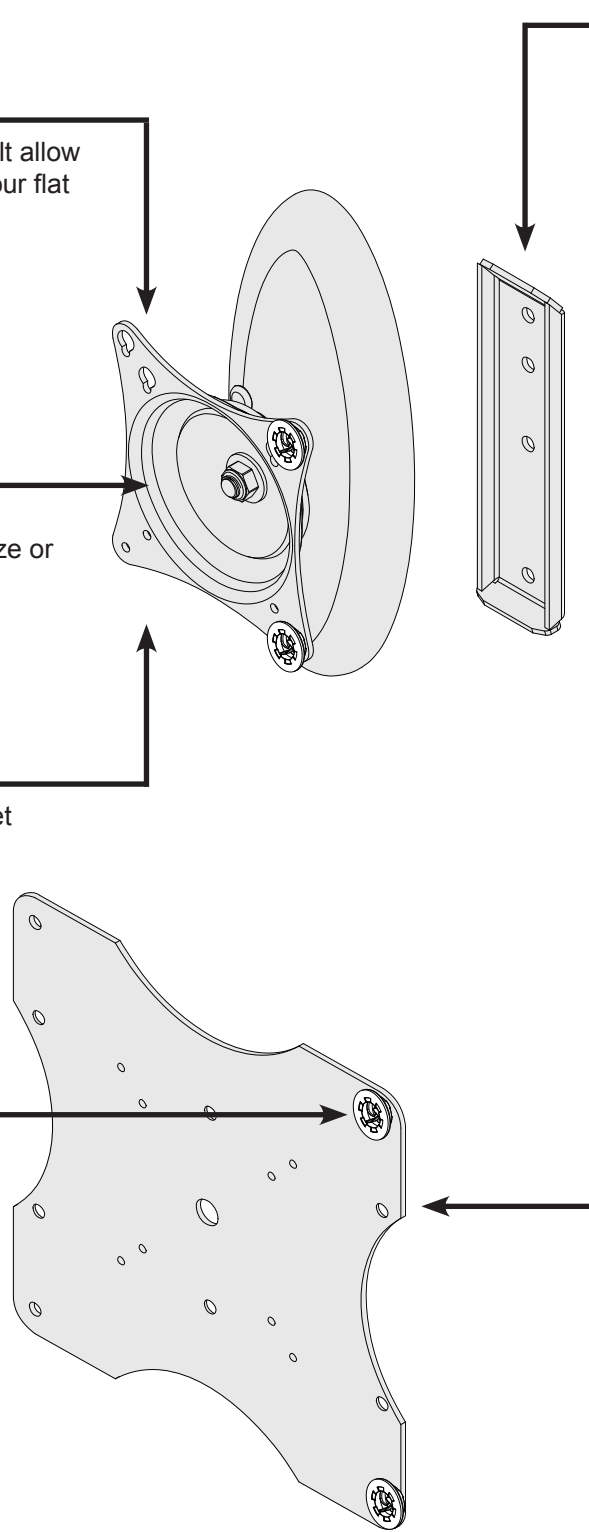



Installing the Wall Plate

Determining the Mounting Surface

If you will be installing your PTM mount to wood studs, proceed to the “**Wood Stud Installation**” section.

If you will be installing your PTM mount to a concrete wall, proceed to the “**Concrete Installation**” section.

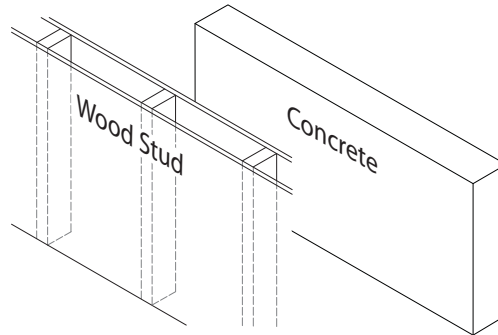

Wood Stud Installation

Step 1

 You must secure the wall plate to the wall stud with all four (4) #14 x 2" wood screws.

- 1 Use a stud finder to determine the exact center of wall studs in the vicinity of the wall plate.
- 2 Use a pencil to mark the exact center of the wall stud where you will be installing your PTM mount.

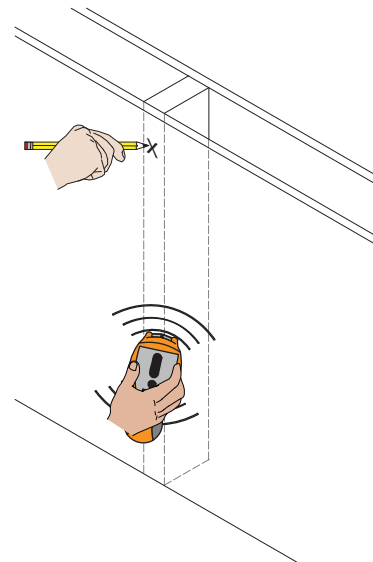

Step 2

- 1 Place the wall plate against the wall in the desired viewing location.
- 2 Adjust the wall plate to align the mounting points in the wall plate with the center of the wall stud.
- 3 Level the wall plate.
- 4 Use a pencil to mark all four (4) mount locations along the center of the wall stud.

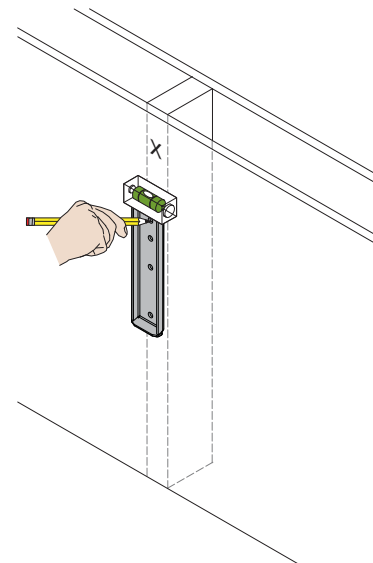



Installing the Wall Plate (cont'd)

Step 3

Drill four (4) holes in the center of each of the marks using a power drill and a $\frac{1}{8}$ " drill bit.

 Only use a $\frac{1}{8}$ " drill bit when drilling the holes.

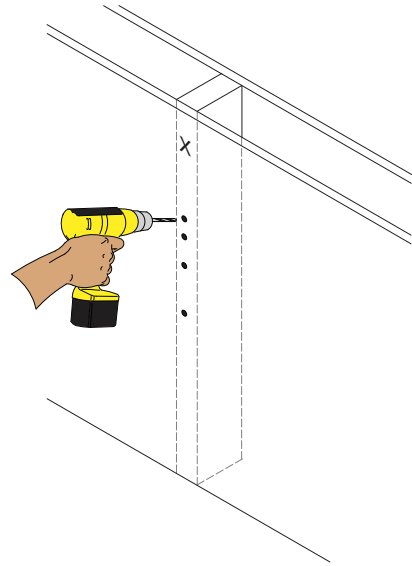

Step 4

- 1 Place the wall plate against the wall and align it with the holes.
- 2 Insert one (1) #14 x 2" wood screw into each of the mounting holes and tighten using a Phillips screwdriver.

 Do not overtighten the wood screws.

Proceed to the "Mounting Hardware" section.

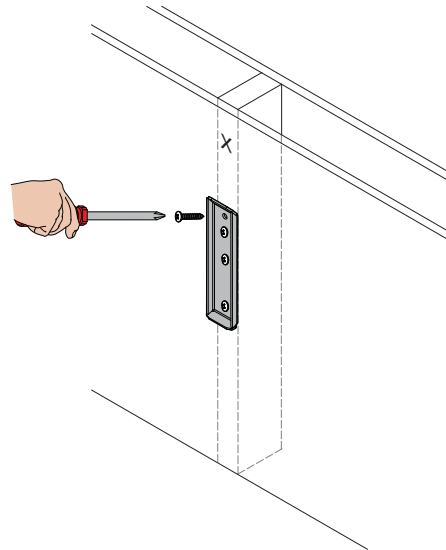

Concrete Installation

 The supplied $\frac{5}{16}$ " concrete wedge anchors must be used for concrete installation.

You will need a $\frac{5}{16}$ " concrete drill bit, which is available at your closest hardware store.

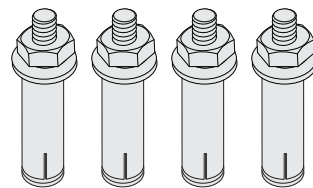

Concrete Wedge Anchors



Example of $\frac{5}{16}$ " Concrete Drill Bit (Not Included)



Installing the Wall Plate (cont'd)

Step 1

- 1 Place the wall plate against the wall in the desired viewing location.
- 2 Level the wall plate.
- 3 Use a pencil and mark all four (4) mounting locations where you will be drilling holes for the concrete wedge anchors.
- 4 Set the wall plate to one side in a safe location.

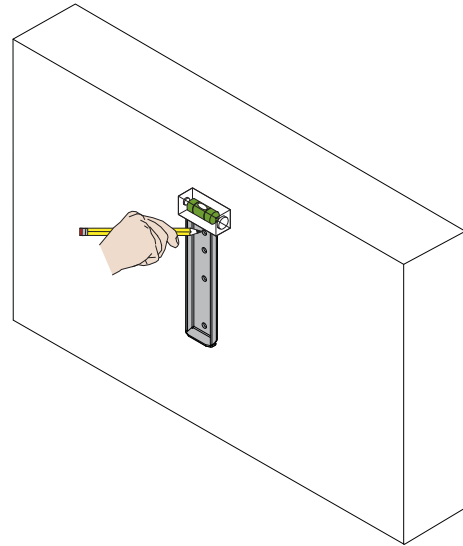

Step 2

Use a power drill and $\frac{5}{16}$ " concrete drill bit to drill a hole at each of the marks.

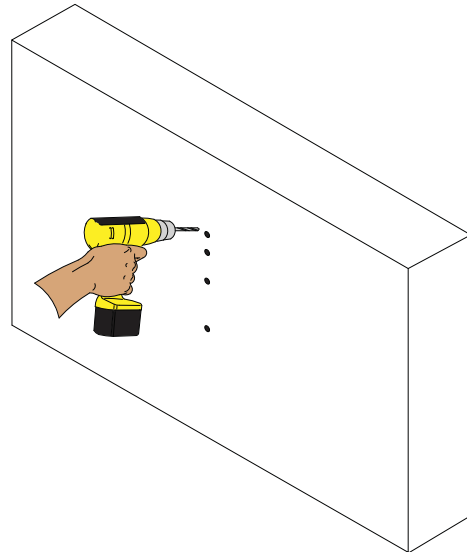

Step 3

- 1 Insert a concrete wedge anchor into each hole.
If necessary, lightly tap each concrete wedge anchor into place with a hammer.
- 2 Remove the nuts and washers from all four (4) concrete wedge anchors.

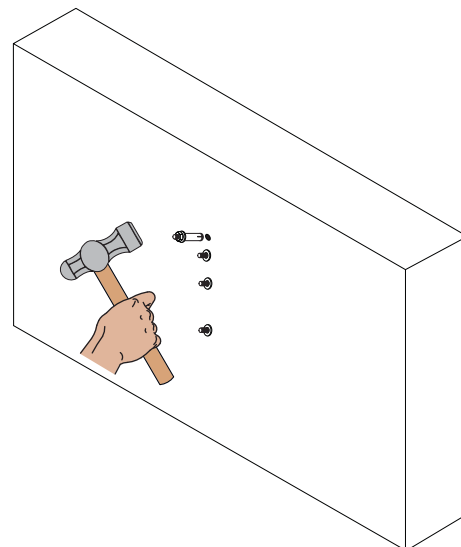



Installing the Wall Plate (cont'd)

Step 4

- 1 Place the wall plate against the wall over the threaded shafts of the concrete wedge anchors.
- 2 Attach the nuts and washers to each of the concrete wedge anchors and tighten using a socket wrench and 1/2" socket.

 Do not overtighten the wedge anchor nuts.

Proceed to the “**Mounting Hardware**” section.

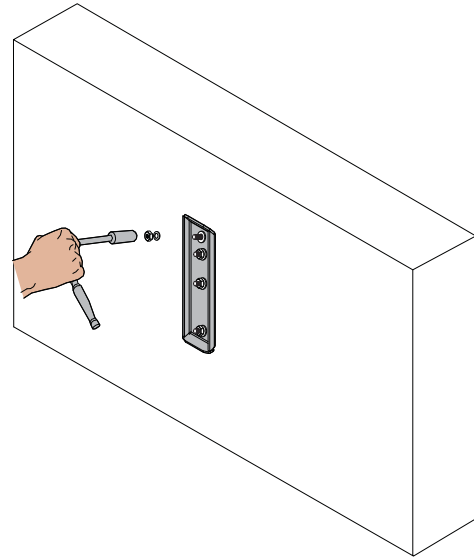

Mounting Hardware

Selecting the Mounting Hardware

- 1 Insert the Thread Depth Indicator into the thread inserts found on the bottom or top of the flat panel.
- 2 Use a pencil to mark the depth of the thread insert on the Thread Depth Indicator, as shown in Figure 1.
- 3 Insert the Thread Depth Indicator into the remaining thread inserts to compare and verify their depth.
- 4 Locate the correct diameter screw for the thread insert.

If the screw you selected is longer than the mark on the Thread Depth Indicator, as shown in Figure 2 and Figure 3, do not use this screw. The screw length must not bypass the mark.

- 5 Test each size of the screws provided.

The correct screws should thread easily into the mounting point and not pull out when tension is applied.

 Does your flat panel have:

- Recessed mounting points?
- Uneven mounting points?
- A curved back?
- Any obstruction near the mounting point?

If **Yes**, you must install Universal Spacers. Proceed to the “**Universal Spacer Installation**” section.

If **No**, skip to the “**UFP-280 Adapter Plate Installation**” section.

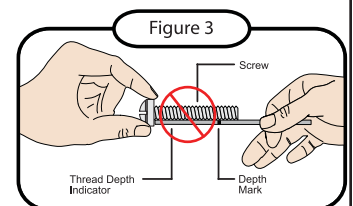
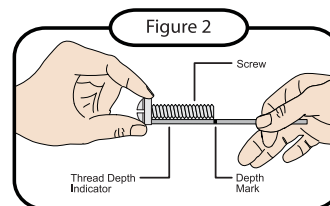
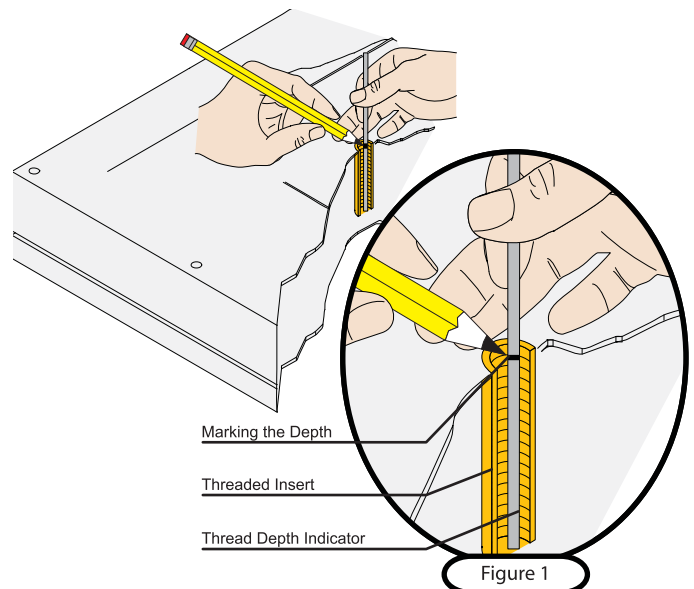

Mounting Hardware (cont'd)

Universal Spacer Installation

Premier Mounts' Universal Spacers allow you to attach the mounting bracket to flat panels which have recessed or uneven mounting points. Each Universal Spacer adds $\frac{1}{4}$ " to the distance between the Adapter Plate and your flat panel.

 The Universal Spacers must be stacked and oriented as shown.

 The Universal Spacers must only be installed between the Adapter Plate and your flat panel.

The Universal Spacers will fit M4, M5, M6 and M8 screw sizes.

 Does your flat panel have:

- 75mm x 75mm VESA mounting points or 100mm x 100mm VESA mounting points?

Proceed to the “**Attaching the Flat Panel to the Mount**” section.

- 100mm x 200mm mounting points or 200mm x 200mm mounting points?

Proceed to the “**UFP-280 Adapter Plate Installation**” section.

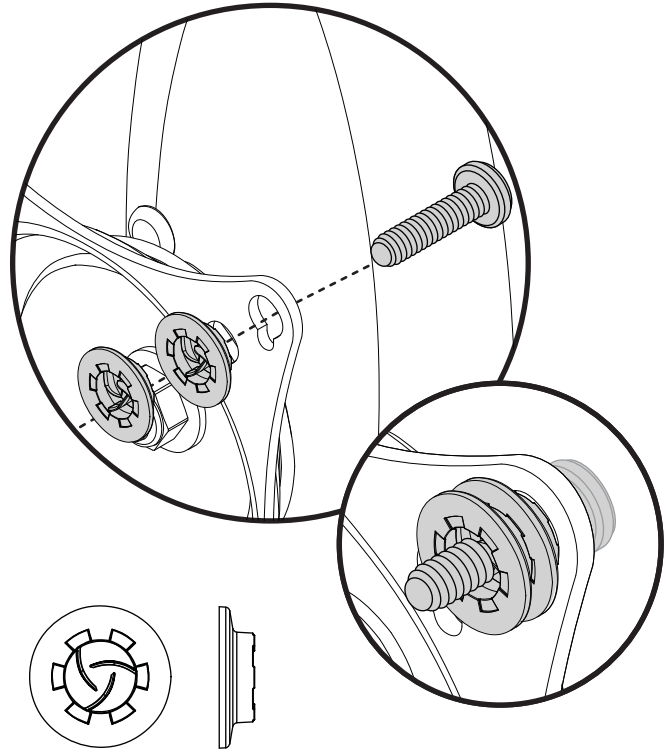

UFP-280 Adapter Plate Installation

The UFP-280 LCD Mount Adapter is used to attach flat panels with 100mm X 200mm and 200mm x 200mm mounting points to the PTM mount.

1 Determine which mounting points will be used.

Refer to the “**Technical Specifications**” section for UFP-280 Adapter Plate mounting points.

2 Place your monitor face-down on a soft and flat surface.

3 Secure the UFP-280 Adapter Plate to the back of the monitor using the following hardware:

- If you are using the 200mm X 100mm mounting points, you must use the M4 x 10mm Phillips flat head screws to secure the UFP-280 Adapter Plate to the flat panel.
- If you are using the 200mm x 200mm mounting points...

...and you selected M4 screws from the “**Selecting the Mounting Hardware**” section, you must also use M4 flat washers.

...and you selected M5 screws from the “**Selecting the Mounting Hardware**” section, you must also use M5 flat washers.

Proceed to the “**Attaching the Flat Panel to the Mount**” section.

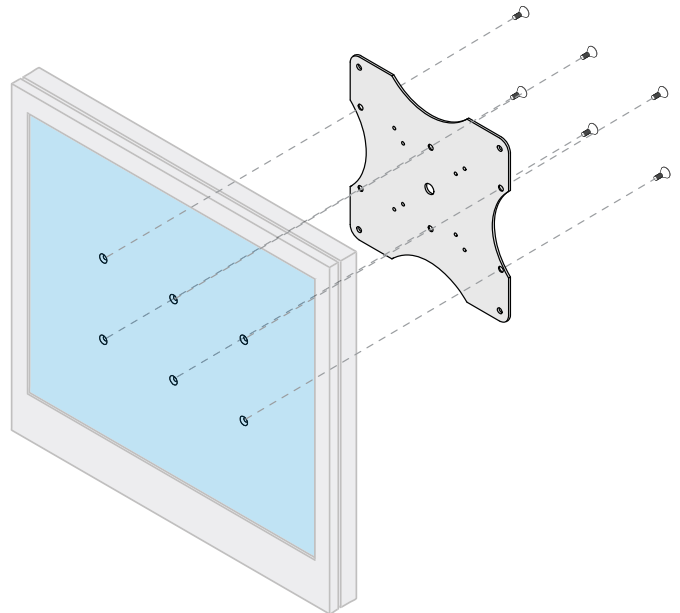



Attaching the Flat Panel to the Mount

- 1 Insert two (2) M4 x 5mm Phillips screws to the top two mounting points of your flat panel. Thread the M4 x 5mm Phillips screws halfway into the flat panel, but do not tighten the screws at this time.

If you are using the UFP-280 Adapter Plate, you can use either of the A or B mounting points. Refer to the “**Technical Specifications**” section for UFP-280 Adapter Plate mounting points.

- 2 Insert the heads of the M4 x 5mm Phillips screws through the keyhole slots.
- 3 Insert two (2) M4 x 5mm Phillips screws into the bottom mounting points.
- 4 Tighten all M4 x 5mm Phillips screws.

 Do not overtighten the mounting hardware.

Proceed to the “**Attaching the Mount to the Wall Plate**” section.

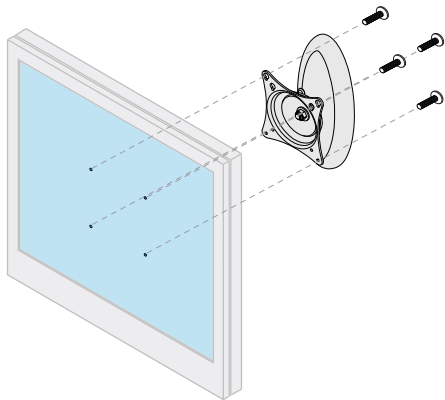

Flat Panel without UFP-280 Adapter Plate

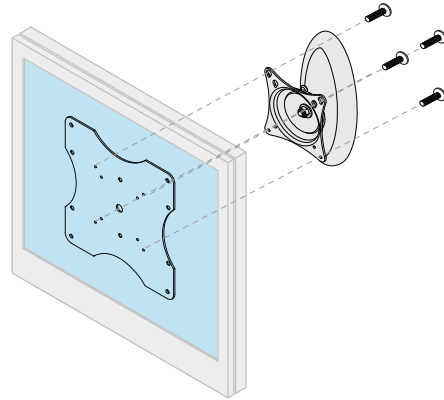

Flat Panel with UFP-280 Adapter Plate

Attaching the Mount to the Wall Plate

Your PTM mount must be attached to the back plate that is secured to the wall. The back of your PTM mount has a built-in bracket designed to “hang” on the wall plate.

- 1 Lift your PTM mount up to the wall plate.
- 2 Slide the top of the PTM mount on to the top of the wall bracket.
- 3 Pivot the bottom of the PTM mount towards the wall plate until it rests against the wall.

 Do not release the PTM mount until you are certain that it is resting securely on the wall plate.

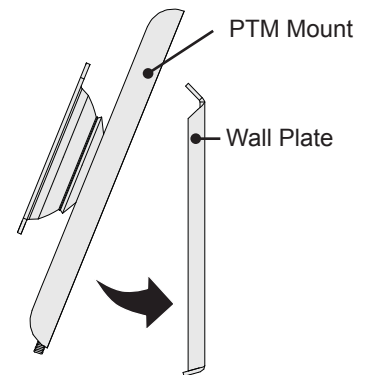

Proceed to the “**Securing the PTM Mount**” section.

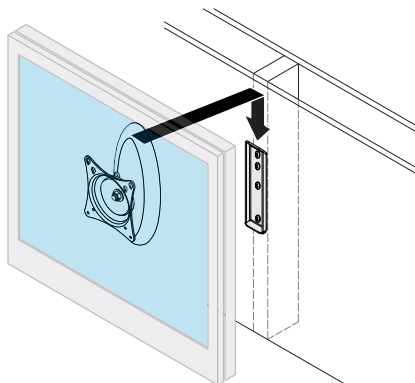

Flat Panel without UFP-280 Adapter Plate

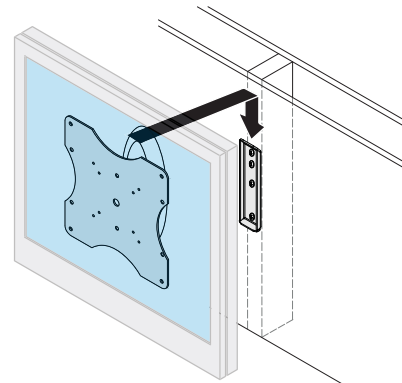

Flat Panel with UFP-280 Adapter Plate



Securing the Mount

Use the M3 Allen wrench to tighten the M6 x 35mm set screw located in the bottom of the PTM mount. The M6 x 35mm set screw prevents your flat panel from being accidentally dislodged.

 Do not overtighten the set screw.

Proceed to the “**Adjusting the Mount Tension**” section.

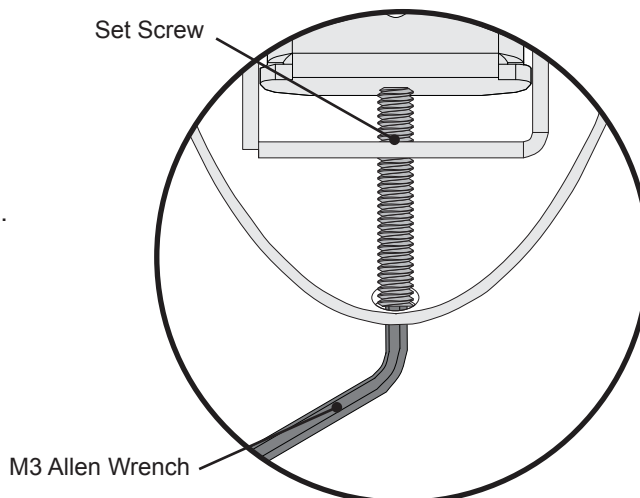

Adjusting the Mount Tension

Removing the Mount

- 1 Use the M3 Allen wrench to loosen the M6 x 35mm set screw at the bottom of the PTM mount.
- 2 Gently lift, then gently pull the PTM mount away from the wall until it disengages from the wall plate.
- 3 Set the flat panel face-down on a soft, flat surface.
- 4 Remove the two (2) M4 x 5mm Phillips screws from the bottom mounting points.
- 5 Loosen the two (2) M4 x 5mm Phillips screws from the top mounting points. Do not completely remove these screws.
- 6 Gently slide the PTM mount towards the bottom of the flat panel and pull towards you until the flat panel disengages from the keyhole slots.

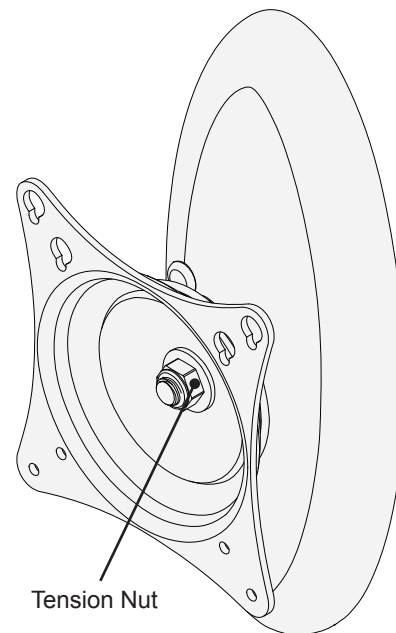



Adjusting the Tension

Use a socket wrench and the supplied 14mm socket to loosen or tighten the tension nut.

- Turn the tension nut clockwise to increase tension.
- Turn the tension nut counter-clockwise to decrease tension.

 Do not overtighten the tension nut.

Replacing the Mount

- 1 Replace PTM mount by guiding the heads of the top two (2) M4 x 5mm Phillips screws through the keyhole slots.
- 2 Insert two (2) M4 x 5mm Phillips screws into the bottom mounting points.
- 3 Tighten all M4 x 5mm Phillips screws.
-  Do not overtighten the M4 x 5mm Phillips screws.
- 4 Lift your PTM mount up to the wall plate.
- 5 Slide the top of the PTM mount on to the top of the wall bracket.
- 6 Pivot the bottom of the PTM mount towards the wall plate until it rests against the wall.
-  Do not release the PTM mount until you are certain that it is resting securely on the wall plate.
- 7 Use the M3 Allen wrench to tighten the M6 x 35mm set screw located in the bottom of the PTM mount.
-  Do not overtighten the set screw.



Technical Specifications

All measurements are in inches [millimeters].

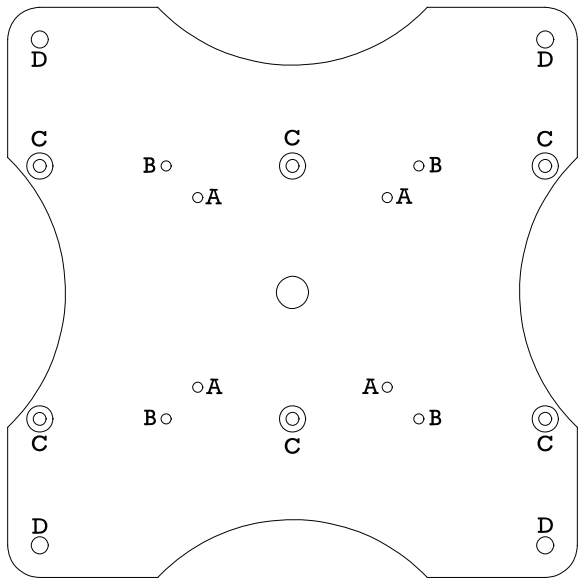
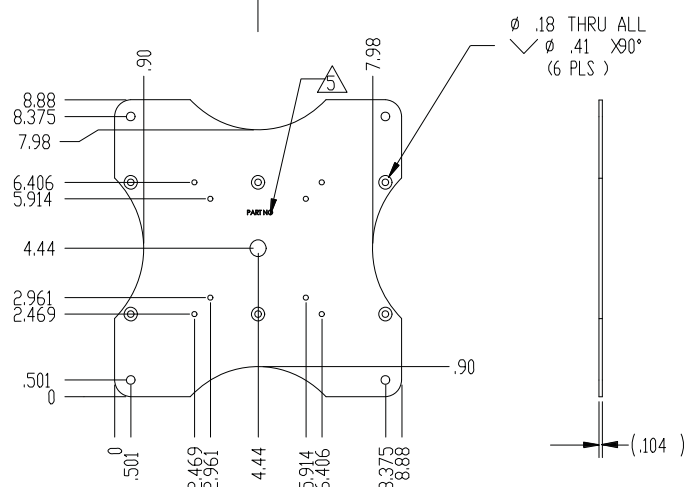
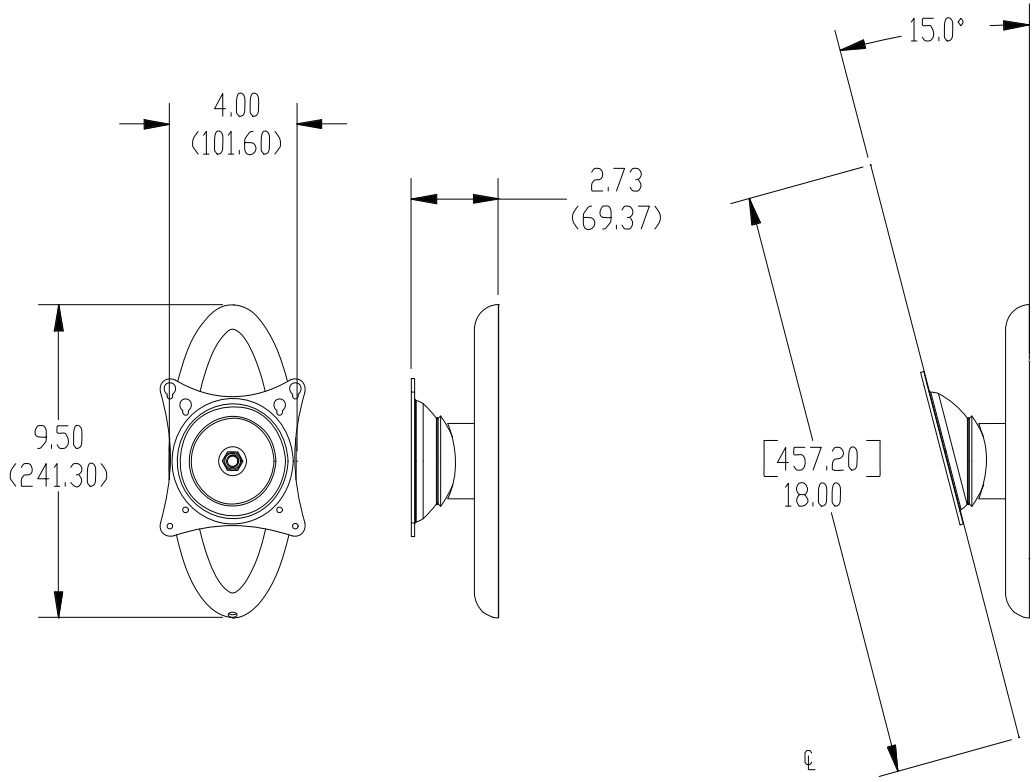

- A: 75mm x 75mm VESA mounting points.
- B: 100mm x 100mm VESA mounting points.
- C: 200mm x 100mm mounting points.
(M4 x 10mm Phillips flat head screws only)
- D: 200mm x 200mm mounting points.
(If M4 screws are used, M5 washers must be used as well)

**PREMIER MOUNTS
LIMITED LIFETIME WARRANTY****What and Who is Covered by this Limited Warranty and for How Long**

Premier Mounts warrants this product to be free from defects in material and workmanship for the lifetime of the original owner of this product. The limited warranty is valid only for the original purchaser of the product.

What Premier Mounts Will Do

At the sole option of Premier Mounts, Premier Mounts will repair or replace any product or product part that is defective. If Premier Mounts chooses to replace a defective product or part, a replacement product or part will be shipped to you at no charge, but you must pay any labor costs.

What is Not Covered; Limitations

PREMIER MOUNTS DISCLAIMS ANY LIABILITY FOR DAMAGE TO MOUNTS, ADAPTERS, DISPLAYS, PROJECTORS, OTHER PROPERTY, OR PERSONAL INJURY RESULTING, IN WHOLE OR IN PART, FROM IMPROPER INSTALLATION, MODIFICATION, USE OR MISUSE OF ITS PRODUCTS.

PREMIER MOUNTS DISCLAIMS ALL OTHER WARRANTIES, EXPRESS OR IMPLIED, INCLUDING WARRANTIES OF MERCHANTABILITY AND FITNESS FOR A PARTICULAR PURPOSE. PREMIER MOUNTS IS NOT RESPONSIBLE FOR INCIDENTAL OR CONSEQUENTIAL DAMAGES, INCLUDING BUT NOT LIMITED TO, INABILITY TO USE ITS PRODUCTS OR LABOR COSTS FOR REMOVING AND REPLACING DEFECTIVE PRODUCTS OR PARTS. SOME STATES DO NOT ALLOW THE EXCLUSION OR LIMITATION OF INCIDENTAL OR CONSEQUENTIAL DAMAGES, SO THE ABOVE LIMITATION OR EXCLUSION MAY NOT APPLY TO YOU.

What Customers Must Do for Limited Warranty Service

If you discover a problem that you think may be covered by the warranty you **MUST REPORT** it in writing to the address below within thirty (30) days. Proof of purchase (an original sales receipt) from the original consumer purchaser must accompany all warranty claims. Warranty claims must also include a description of the problem, the purchaser's name, address, and telephone number. General inquiries can be addressed to Premier Mounts Customer Service at 1-800-368-9700. Warranty claims will not be accepted over the phone or by fax.

Premier Mounts
Attn: Warranty Claim
3130 East Miraloma Ave.
Anaheim, CA 92806

How State Law Applies

THIS WARRANTY GIVES YOU SPECIFIC LEGAL RIGHTS, AND YOU MAY ALSO HAVE OTHER RIGHTS WHICH VARY FROM STATE TO STATE.

Disclaimer

Premier Mounts intends to make this manual accurate and complete. However, Premier Mounts makes no claim that the information contained herein covers all details, conditions or variations, nor does it provide for every possible contingency in connection with the installation or use of this product. The information contained in this document is subject to change without notice or obligation of any kind. Premier Mounts makes no representation of warranty, expressed or implied, regarding the information contained herein. Premier Mounts assumes no responsibility for accuracy, completeness or sufficiency of the information contained in this document.