

The ActivTable is a multi-user interactive table allowing up to six learners to simultaneously use individual tools, web browsers and resources as their personal efforts move the group toward accomplishing a common goal. Extensive educational activities, an image bank and reporting tools are included. Using the ActivTable Activity Builder, a free, web-based application, additional activities can be created for use on the ActivTable to complement lessons and teaching objectives.

### GENERAL SPECIFICATIONS

User Input	Touch
Number of Touches	12 perfect simultaneous touches
Touch Technology	Infra-red based detection system
Display Technology	Horizontal HD LCD Panel
Power Requirement	Mains Powered; Dual Voltage 100 - 240v AC
Power Consumption	Standby 0.15A (36W), In Use 1.2A (288W) (Based on 240v mains)
Connectivity	4 x USB-A ports, 3.5mm mic in socket, 4 x 3.5 mm stereo headphone sockets, DVI, Ethernet port, WiFi
Screen Surface	Toughened Safety Glass
Certifications	NRTL, CE, FCC, GOST, SABS
ActivTable Software Language Support	English, Simplified Chinese, Russian, Finnish, Indonesian, Arabic; Localized keyboards for Danish, Norwegian and Swedish
Integrated Sound	Two integrated 10W speakers and integrated class-D amplifier (volume controlled via the ActivTable software)
Packed Contents List	ActivTable including ActivTable software, educational activities, tools and resources, embedded training resources and Quick Start Guide, Installation Guide, Health and Safety Guide, Power Cords x4 (AU, EU, UK, US), Allen key, fixings and Cover.



### SPECIFICATIONS

Active Area Diagonal	1170mm (46")
Resolution	1920x1080
Screen Format	16:9
Overall Dimensions	1200mm x 752mm x 725mm (47.2in x 29.6in x 28.5in)
Active Area Dimensions	1020mm x 572mm (40.2in x 22.5in)
Mobility	4 free-wheeling castors, plus locking feet to secure ActivTable in position
Operating Temperature	5°C to 30°C (41°F to 86°F)
Storage Temperature	-20°C to 60°C (-4°F to 140 °F)
Table Weight	69.5kg (153lbs)
Packed Weight & Dimensions	<p><b>Box 1 of 3:</b> 64.7kg (142.3lbs) Dimensions: 1280mm x 840mm x 215mm (50.4in x 33.1in x 8.5in)                      T-SURFACE Contents: Table surface, Installation Guide, Health and Safety Guide.</p> <p><b>Box 2 of 3</b> 23.3kg (51.3lbs) Dimensions: 755mm x 390mm x 377mm (29.7in x 15.4in x 14.8in)                      T-LEGS-M Contents: Table legs, power cords x4 (AU, EU, UK, US), Allen Key and fixings</p> <p><b>Box 3 of 3</b> 2kg (4.5lbs)                      Dimensions: 780mm x 430mm x 50mm (31in x 17in x 2in) T-COVER Contents: ActivTable Cover</p>

**MINIMUM COMPUTER REQUIREMENTS**

<b>Operating System</b>	The ActivTable does not require a computer. ActivTable Operating System: Microsoft Windows 7 Embedded
<b>Internet</b>	Internet access recommended for optimal use – wireless or wired to download updates and activities; many activities use the internet
<b>ActivTable Activity Builder</b>	The ActivTable Activity Builder, a free web-based application, requires Google Chrome version 30.x or above.

**SYSTEM OVERVIEW**

<b>Installation</b>	It is recommended that the ActivTable is installed by a Certified Promethean Installer. Two people will be required to install the ActivTable. A keyboard and mouse will be required for set up (not supplied). For optimum performance, Promethean recommends the ActivTable is installed away from direct lighting or sunlight.  Components supplied and minimum specifications stated have been tested and are required for optimal performance. Use of components not supplied by Promethean or not meeting minimum specifications may impact performance and affect warranty. Contact your Promethean partner or visit www.PrometheanKB.com for more information.
---------------------	--

**TECHNICAL DRAWING**

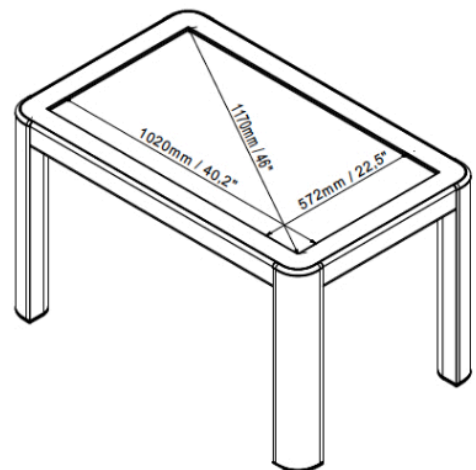
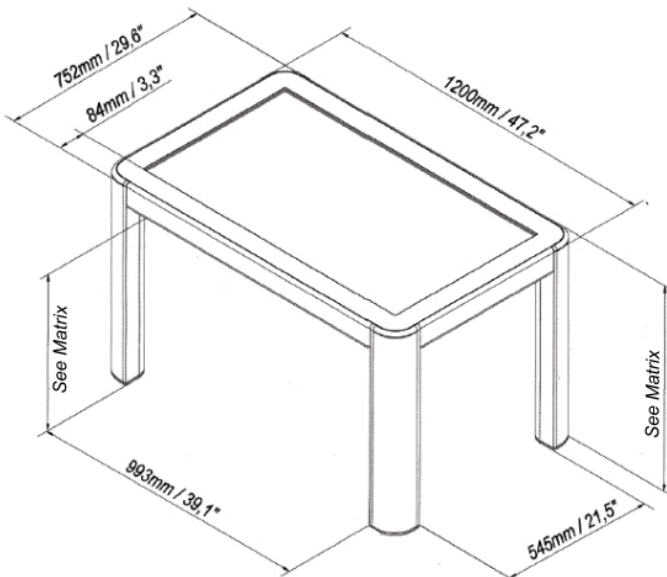

ActivTable Variant	Underside Height	Overall Height
ACTIVTABLE	582mm / 22.9in	725mm / 28.5in
ACTIVTABLE-S	472mm / 18.6in	615mm / 24.2in
ACTIVTABLE-L	692mm / 27.2in	835mm / 32.9in