

# ActivBoard 500 PRO Adjustable System

INTERACTIVE DISPLAY

## Product Specifications



205 Westwood Ave, Long Branch, NJ 07740  
Phone: 866-94 BOARDS (26273) / (732)-222-1511  
Fax: (732)-222-7088 | E-mail: sales@touchboards.com



ActivBoard 500 Pro Adjustable  
with PRM-30a or PRM-35 projector



ActivBoard 500 Pro Adjustable  
with EST-P1 projector

### THIS DOCUMENT CONTAINS SPECIFICATIONS FOR

ActivBoard  
Adjustable Frame  
Projector

### DESCRIPTION

The ActivBoard 500 Pro with Dual-User Pen and Touch capability is available in 78", 87" and 95" versions with integrated slim-line speakers and amplifier, ActivInspire Professional Edition, Promethean ActivOffice and Promethean Applications software. The Adjustable System includes a height-adjustable wall mount and choice of Extreme Short Throw or Short Throw projector.

### SYSTEM OVERVIEW

#### Installation

The installation of this product should be completed by a Promethean Certified Installer. Please visit [www.PrometheanWorld.com/ActivCare/installationtc](http://www.PrometheanWorld.com/ActivCare/installationtc). Components supplied and minimum specifications stated have been tested and are required for optimal performance. Use of components not supplied by Promethean or not meeting minimum specifications may impact performance and affect warranty. Contact your Promethean partner or visit [www.PrometheanKB.com](http://www.PrometheanKB.com) for more information

#### Warranty

For Promethean Warranty Information please visit: [www.PrometheanWorld.com/ActivCare](http://www.PrometheanWorld.com/ActivCare)

#### Support

Online Support for all Promethean Products available from: [www.PrometheanKB.com](http://www.PrometheanKB.com)

#### Complete System Weight (approx.)

**ActivBoard 578 Pro including;**  
PRM-30a Projector 97kg (213.8lb)  
PRM-35 Projector 94kg (207.2lb)

**ActivBoard 587 Pro including;**  
PRM-30a Projector 100kg (220.5lb)  
PRM-35 Projector 97kg (213.8lb)

**ActivBoard 595 Pro including;**  
PRM-30a Projector 102.1kg (225.1kg)  
PRM-35 Projector 99.1kg (218.5lb)

**ActivBoard 578 Pro including;**  
EST-P1 Projector 98.5kg (217.2lb)

**ActivBoard 587 Pro including;**  
EST-P1 Projector 101.5kg (223.8lb)

**ActivBoard 595 Pro including;**  
EST-P1 Projector 103.6kg (228.4lb)

ActivBoard Systems/Boards SS 02/12 V3.0 US

©2012 Promethean Limited. All rights reserved. Promethean Ltd. is owner of a number of trademarks in several jurisdictions across the world. Any third-party product and company names are mentioned for identification purposes only and may be trademarks of their respective owners. <sup>1</sup>Applicable Terms and Conditions for warranty and support available at [www.PrometheanWorld.com/ActivCare](http://www.PrometheanWorld.com/ActivCare). All dimensions +/- 5mm (0.2in). All weights +/- 0.9kg (2lb). Product Specifications are subject to change without notice. [www.PrometheanWorld.com](http://www.PrometheanWorld.com)



### UPGRADE AND ACCESSORY OPTIONS

#### Cable Wall Box

Connectivity box with inputs for 2 x fully wired VGA (to support VESA DDC) plus 3.5mm stereo jack audio inputs, USB-B input (for ActivBoard), S-Video, composite video plus auxiliary audio jack inputs, Cat 5e Ethernet input. Allows additional flexibility during installation, where the computer is located further away from the System

#### ActivWand 50

Wireless, battery-free and extended reach input device for the ActivBoard – 540mm (21.2in) in length; “left click”, cursor and hover, just like a mouse

#### Dry Erase Whiteboard

Optional dry erase whiteboard, can use 1 or 2 dry erase whiteboards per System

#### ActivBoard System Shelf

Storage for 1 laptop, with a maximum size of a standard 43cm (17in) laptop. Lockable System Shelf also available as an option

### TECHNICAL DRAWING

#### PRM-30a

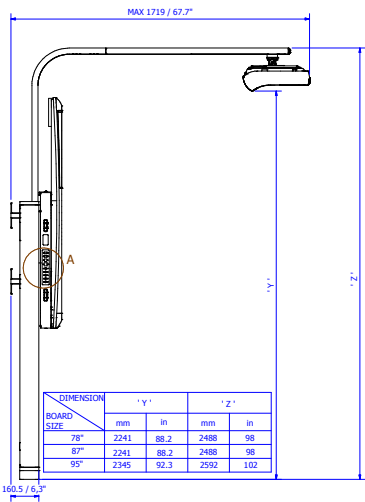

#### PRM-35

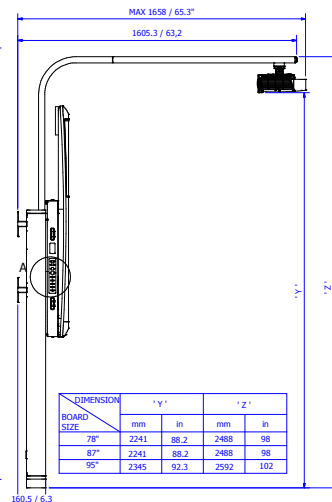

#### EST-P1

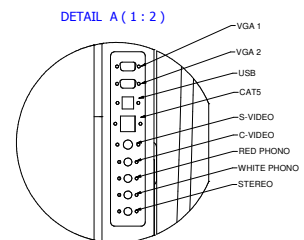
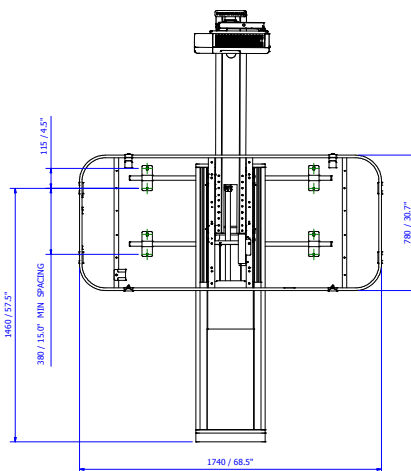
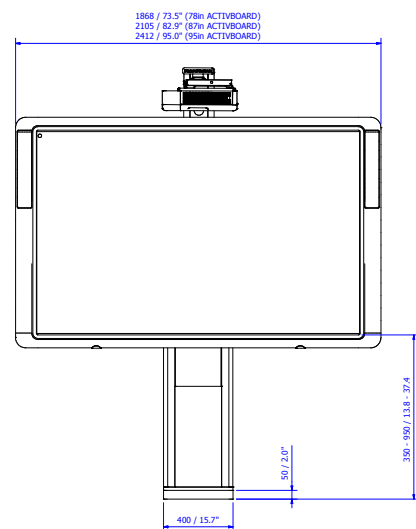
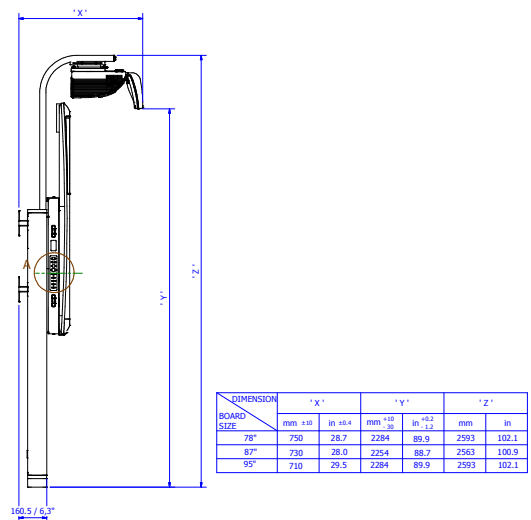

### ACTIVBOARD GENERAL SPECIFICATIONS

Model	ActivBoard 500 Pro Range
Pen Internal Resolution	2730 points (lines) per inch
Pen Output Resolution	200 points (lines) per inch
Pen Tracking Rate	200 inches per second providing a fast response to pen commands
Pen Output Rate	160 coordinate pairs per second (single user) 80 coordinate pairs per second (dual user)
User Input	Cordless battery-free pen incorporating tip switch and side switch for full mouse functionality (ActivPen) and touch
Touch Resolution	200 points (lines) per inch
Touch Output Rate	80 coordinate pairs per second
Touch Response Rate	10 ms
Maximum Simultaneous Touches	2 with ActivInspire 4 with Windows 7
Digitizing Technology	Passive Electromagnetic and Capacitive sensing interface
Power Requirement	Mains Powered; 18V Power Supply Unit
Connection to Computer	USB 2.0, 1 x 3m USB 2.0 data cable supplied
Connection to Peripherals	2 x USB ports on left hand side
Screen Surface	Low Glare Melamine
Certifications	UL, CE, FCC
Operating Temperature Range	0°C to +40°C (32°F to 104°F)
Storage Temperature Range	-20°C to +60°C (-4°F to 140°F)
Storage Humidity	10% to 90% (non-condensing)
Dual User Functionality	<b>Pen:</b> 1 Instructor ActivPen and 1 Participant ActivPen can be used together in Dual-User Mode when using ActivInspire 1.5 Professional Edition and above <b>Pen and Touch:</b> 1 Participant ActivPen and simultaneous additional two-touch gesture supported when using ActivInspire 1.5 Professional Edition and above
Single User Functionality	<b>Pen:</b> 1 Instructor ActivPen <b>Touch:</b> Two-touch gesture supported when using ActivInspire 1.5 Professional Edition and above
Integrated USB Sound	Two integrated slim-line speakers and amplifier (with controls, inputs and outputs)
Packed Contents List	ActivBoard 587 Pro or ActivBoard 595 Pro, 2 Instructor ActivPens, 2 Participant ActivPens, 1 AMP PSU, Wall Mounting Brackets, User Guide, Access to ActivInspire Professional Edition, Promethean ActivOffice and Promethean Applications via download. (ActivInspire Professional Edition is also available on DVD on request), 1 x 3m USB data cable



205 Westwood Ave, Long Branch, NJ 07740  
Phone: 866-94 BOARDS (26273) / (732)-222-1511  
Fax: (732)-222-7088 | E-mail: sales@touchboards.com

ActivBoard Systems/Boards SS 02/12 V3.0 US



©2012 Promethean Limited. All rights reserved. Promethean Ltd. is owner of a number of trademarks in several jurisdictions across the world. Any third-party product and company names are mentioned for identification purposes only and may be trademarks of their respective owners. <sup>1</sup>Applicable Terms and Conditions for warranty and support available at [www.PrometheanWorld.com/ActivCare](http://www.PrometheanWorld.com/ActivCare). All dimensions +/- 5mm (0.2in). All weights +/- 0.9kg (2lb). Product Specifications are subject to change without notice. [www.PrometheanWorld.com](http://www.PrometheanWorld.com)

### INTEGRATED USB SOUND SPECIFICATIONS

Amplifier Power Output	20W per channel RMS (<1% distortion)
Controls	Volume, Bass, Treble, on/off
Amplifier Frequency Response	40Hz to 18kHz +/-3dB (at 1W)
USB Sound	USB Sound supported for Minimum System Requirements stated
Connectivity – Inputs (4)	Stereo PC, Stereo CD/DVD, Mono Auxiliary, Microphone to PC
Connectivity – Outputs (2)	2 Stereo
Power Requirement	18V 5 Amp

### ACTIVBOARD SPECIFICATIONS

Model	ActivBoard 578 Pro	ActivBoard 587 Pro	ActivBoard 595 Pro
ActivBoard Size	78in	87in	95in
Resolution	12800 x 9200	14600 x 9200	17200 x 9200
Screen Formats	4:3	16:10	16:9
Overall Dimensions	1868mm x 1329mm 973.5in x 52.3in)	2105mm x 1329mm (82.9in x 52.3in)	2336mm x 1329mm (92in x 52.3in)
Active Area Dimensions	1628mm x 1175mm (64in x 46in)	1865mm x 1175mm (73.4in x 46.3in)	2095mm x 1175mm (82.5in x 46.3in)
Active Area Diagonal	2000mm (78.7in)	2196mm (86.5in)	2394mm (94.3in)
Actual Image Diagonal	1958mm (77.1in)	2193mm (86.4in)	2392mm (94.2in)
Board Weight	37kg (81.6lb)	40kg (88lb)	48kg (106lb)
Packed Weight	52kg (114.6lb)	57kg (126lb)	65kg (143lb)
Packed Dimensions	2025mm x 1500mm x 110mm (79.9in x 59in x 4.3in)	2270mm x 1500mm x 110mm (89.4in x 59.1in x 4.3in)	2572 mm x 1495mm x 110mm (101.3in x 58.9in x 4.33in)

### MINIMUM COMPUTER REQUIREMENTS

Operating Systems	Windows XP SP3 and above (XP/Vista/7); Mac OSX 10.4.11 – 10.6.4 (Tiger/Leopard/Snow Leopard); Linux Ubuntu 9.10 or 10.04; Debian Lenny; Linex Colegios 2010; Linkat 3; ALT_Linux (Russia)
PC	2.0 GHz Intel Core 2 Duo or faster for HD-quality videos, 1 GB of RAM is required to play HD-quality videos, 1024 x 768 resolution, 1.5 GB of Free Disk Space
Mac	2.0 GHz Intel Core 2 Duo, 512 MB of RAM, 1024 x 768 resolution, 3.0 GB of Free Disk Space
Linux	2.0 GHz Processor or faster for HD-quality videos, 1 GB of RAM is required to play HD-quality videos, 1024 x 768 resolution, 1.5 GB of Free Disk Space

ActivBoard Systems/Boards SS 02/12 V3.0 US

©2012 Promethean Limited. All rights reserved. Promethean Ltd. is owner of a number of trademarks in several jurisdictions across the world. Any third-party product and company names are mentioned for identification purposes only and may be trademarks of their respective owners. <sup>1</sup>Applicable Terms and Conditions for warranty and support available at [www.PrometheanWorld.com/ActivCare](http://www.PrometheanWorld.com/ActivCare). All dimensions +/- 5mm (0.2in). All weights +/- 0.9kg (2lb). Product Specifications are subject to change without notice. [www.PrometheanWorld.com](http://www.PrometheanWorld.com)

# Product Specifications

## ADJUSTABLE FRAME SPECIFICATIONS

Projector Model	Short Throw	Extreme Short Throw
<b>Height Settings</b>	Height-adjustable mount, with 600mm (23.6in) of adjustment from 350mm (13.8in) to 950mm (37.4in) ± 50mm (1.9in). Top and bottom limit stops are fitted if the full range of movement is not required/appropriate. Height adjustment is powered by an electrical motor and is operated using a switch on the side of the stand	Height-adjustable mount, with 600mm (23.6in) of adjustment from 350mm (13.8in) to 950mm (37.4in) ± 50mm (1.9in). Top and bottom limit stops are fitted if the full range of movement is not required/appropriate. Height adjustment is powered by an electrical motor and is operated using a switch on the side of the stand
<b>Projector Mount</b>	Aluminum arm, extends 1605mm (63in) from the wall, adjusts with the height of the ActivBoard reducing the need for specific re-calibration following height adjustment	Aluminum arm, extends 550mm (21.7in) from the wall, adjusts with the height of the ActivBoard reducing the need for specific re-calibration following height adjustment
<b>Room Height Requirements</b>	Min. 2.66m (104.7in) for full range operation	Min. 2.66m (104.7in) for full range operation
<b>Integrated Power Management</b>	For ActivBoard, Projector and Actuator	For ActivBoard, Projector and Actuator
<b>Actuator</b>	<p>Input Voltage: 24VDC            Max Load: 750N            Static Load: more than 750N            Speed: 30mm/s (no load), 20mm/s (750N)            Stroke Length: 600 ± 2mm            Retracted Length: 795 ± 2mm            End Mounting Dimension: H Type, ø10.1 hole, 6.3mm Slot            Limit Switch: Built-in            Duty Cycle: S2-10min            Temperature: -26° to 65°C            IP Degree: IP54            AC-DC Adaptor:            Input Voltage: 100 ~ 240VAC            Output Voltage: 29VDC            Current: 2Amp (4Amp protected)            Cable and Plug: 1.5m, IEC Plug</p>	<p>Input Voltage: 24VDC            Max Load: 750N            Static Load: more than 750N            Speed: 30mm/s (no load), 20mm/s (750N)            Stroke Length: 600 ± 2mm            Retracted Length: 795 ± 2mm            End Mounting Dimension: H Type, ø10.1 hole, 6.3mm Slot            Limit Switch: Built-in            Duty Cycle: S2-10min            Temperature: -26° to 65°C            IP Degree: IP54            AC-DC Adaptor:            Input Voltage: 100 ~ 240VAC            Output Voltage: 29VDC            Current: 2Amp (4Amp protected)            Cable and Plug: 1.5m, IEC Plug</p>
<b>Frame Weight (approx.)</b>	52.9kg (116.6lb) excl. board, projector and cabling	51.3kg (113.1lb) excl. board, projector and cabling
<b>Connectivity Panel</b>	Connectivity panel with inputs for 2 x fully wired VGA (to support VESA DDC) plus 3.5mm stereo jack audio inputs, USB-B input (for ActivBoard), S-Video, composite video plus auxiliary audio jack inputs, Cat 5e Ethernet input. Connectivity panel can be mounted on the left or right-hand side of the frame	Connectivity panel with inputs for 2 x fully wired VGA (to support VESA DDC) plus 3.5mm stereo jack audio inputs, USB-B input (for ActivBoard), S-Video, composite video plus auxiliary audio jack inputs, Cat 5e Ethernet input. Connectivity panel can be mounted on the left or right-hand side of the frame

CONTINUED ON NEXT PAGE

ActivBoard Systems/Boards SS 02/12 V3.0 US

©2012 Promethean Limited. All rights reserved. Promethean Ltd. is owner of a number of trademarks in several jurisdictions across the world. Any third-party product and company names are mentioned for identification purposes only and may be trademarks of their respective owners. <sup>1</sup>Applicable Terms and Conditions for warranty and support available at [www.PrometheanWorld.com/ActivCare](http://www.PrometheanWorld.com/ActivCare). All dimensions +/- 5mm (0.2in). All weights +/- 0.9kg (2lb). Product Specifications are subject to change without notice. [www.PrometheanWorld.com](http://www.PrometheanWorld.com)



## ADJUSTABLE FRAME SPECIFICATIONS (CONTINUED)

### Cables

Cable assembly includes; 2 x 4m (13.1ft) VGA panel mount (fully wired to support VESA DDC), 4m (13.1ft) S-Video panel mount, 4m (13.1ft) composite video panel mount, 4m (13.1ft) Ethernet panel mount, 2.8m (9.2ft) USB cable, 2.5m (8.2ft) right angle stereo jack to panel mount jack socket, 2.5m (8.2ft) right angle stereo jack to panel mount phono pair, for PC audio input. To connect the computer to the face plate: 2m (6.6ft) USB patch cable; and a 2m (6.6ft) VGA cable provided in the projector box

Cable assembly includes; 2 x 4m (13.1ft) VGA panel mount (fully wired to support VESA DDC), 4m (13.1ft) S-Video panel mount, 4m (13.1ft) composite video panel mount, 4m (13.1ft) Ethernet panel mount, 2.8m (9.2ft) USB cable, 2.5m (8.2ft) right angle stereo jack to panel mount jack socket, 2.5m (8.2ft) right angle stereo jack to panel mount phono pair, for PC audio input. To connect the computer to the face plate: 2m (6.6ft) USB patch cable; and a 2m (6.6ft) VGA cable provided in the projector box

### Pack Weights & Dimensions

**Box 1 of 3:** 22.4kg (49.4lb)  
 Dimensions: 217mm x 1427mm x 467mm  
 (8.54in x 56.18in x 18.39in)  
 Contents: Boom  
**Box 2 of 3:** 27kg (59.5lb)  
 Dimensions: 182mm x 1652mm x 442mm  
 (7.2in x 65in x 17.4in)  
 Contents: Spine  
**Box 3 of 3:** 15kg (33.1lb)  
 Dimensions: 128mm x 1782mm x 822mm  
 (5.04in x 70.16in x 32.36in)  
 Contents: Frame

**Box 1 of 3:** 19.6kg (43.2lb)  
 Dimensions: 217mm x 1427mm x 467mm  
 (8.54in x 56.18in x 18.39in)  
 Contents: Boom  
**Box 2 of 3:** 27kg (59.5lb)  
 Dimensions: 182mm x 1652mm x 442mm  
 (7.2in x 65in x 17.4in)  
 Contents: Spine  
**Box 3 of 3:** 15kg (33.1lb)  
 Dimensions: 128mm x 1782mm x 822mm  
 (5.04in x 70.16in x 32.36in)  
 Contents: Frame

# Product Specifications

## PROJECTOR SPECIFICATIONS

Model	EST-P1 (DLP)	PRM-35 (DLP)	PRM-30a (LCD)
Native Resolution	WXGA (1280 x 800)	WXGA (1280 x 800)	WXGA (1280 x 800)
Compressed Resolution	up to 1080i	up to 1080i	up to 1080i
Typical Colors	16.77 million colors	16.77 million colors	16.77 million colors
Brightness (ANSI lumens)	2200 ANSI (normal) 2500 ANSI (high)	2100 ANSI (normal) 2500 ANSI (high)	1900 ANSI (normal) 2500 ANSI (high)
Contrast Ratio	2000:1	2000:1	500:1
Noise Level	27dB (normal) 31dB (high brightness mode)	32dB (normal) 36dB (high brightness mode)	29dB (normal) 36dB (high brightness mode)
Dimensions (w x d x h)	354mm x 319mm x 157mm (13.9in x 12.6in x 6.1in) not including lens 354mm x 411mm x 219mm (13.9in x 16.1in x 8.6in) including lens	306mm x 275mm x 97mm (12in x 3.8in x 10.1in)	382mm x 430mm x 129mm (15in x 16.9in x 5in)
Weight	9kg (19.8lb)	2.7kg (6lb)	5.7kg (12.5lb)
Aspect Ratio	16:10 (native), 4:3, 16:9	16:10 (native), 4:3, 16:9	16:10 (native), 4:3, 16:9
Power Consumption	290W (<1W standby)	230W (<1W standby)	317W (<0.8W standby)
Device Type	DLP Technology	DLP Technology	LCD Technology
Focus	Manual Focus	Manual Focus	Manual Focus
Zoom	N/A	Digital Zoom	Digital Zoom
Focal Length	F=2.4	F=2.86	Fixed
Projection Distance	0.39m ~ 0.56m (15in ~ 22in)	0.54m ~ 1.22m (21.3in ~ 48in)	0.54m ~ 1.22m (21.3in ~ 48in)
Projection Screen Size	1.98m ~ 2.79m (78in ~ 110in)	1.27m ~ 2.79m (50in ~ 110in)	1.27m ~ 2.79m (50in ~ 110in)
Lamp Type	220W lamp	230W lamp	230W lamp
Lamp Life	6000hrs (normal), 4000hrs (high)	6000hrs (normal), 4000hrs (high)	4000 hrs (normal), 3000 hrs (high)
Keystone Correction	Vertical: max ±15°	Vertical: max ±15°	Vertical: max ±20°
Operating Temperature	5°C ~ 35°C (41°F ~ 95°F)	5°C ~ 35°C (41°F ~ 95°F)	5°C ~ 35°C (41°F ~ 95°F)
Power Supply Voltage	100 - 240V AC, 50/60Hz	100 ~ 240V AC, 50/60Hz	100 ~ 240V AC, 50/60Hz
Horizontal Scan Rate	15Hz ~ 90kHz	15Hz ~ 90kHz	15Hz ~ 90kHz
Vertical Scan Rate	43Hz ~ 85Hz	50Hz ~ 85Hz	50Hz ~ 85Hz

CONTINUED ON NEXT PAGE

ActivBoard Systems/Boards SS 02/12 V3.0 US

©2012 Promethean Limited. All rights reserved. Promethean Ltd. is owner of a number of trademarks in several jurisdictions across the world. Any third-party product and company names are mentioned for identification purposes only and may be trademarks of their respective owners. <sup>1</sup>Applicable Terms and Conditions for warranty and support available at [www.PrometheanWorld.com/ActivCare](http://www.PrometheanWorld.com/ActivCare). All dimensions +/- 5mm (0.2in). All weights +/- 0.9kg (2lb). Product Specifications are subject to change without notice. [www.PrometheanWorld.com](http://www.PrometheanWorld.com)



### PROJECTOR SPECIFICATIONS (CONTINUED)

<b>Computer Compatibility</b>	IBM PC and Compatibles; Apple Macintosh, iMac, and VESA Standards WSXGA+ (1,680 x 1,050), WXGA+ (1,440 x 900), WXGA (1,280 x 800, 1,280 x 768), UXGA (1,600 x 1,200), SXGA+ (1,400 x 1,050), SXGA (1,280 x 1,024), XGA (1,024 x 768), SVGA (800 x 600), VGA (640 x 480)	IBM PC and Compatibles; Apple Macintosh, iMac, and VESA Standards WSXGA+ (1,680 x 1,050), WXGA+ (1,440 x 900), WXGA (1,280 x 800, 1,280 x 768), UXGA (1,600 x 1,200), SXGA+ (1,400 x 1,050), SXGA (1,280 x 1,024), XGA (1,024 x 768), SVGA (800 x 600), VGA (640 x 480)	IBM PC and Compatibles; Apple Macintosh, iMac, and VESA Standards WSXGA+ (1,680 x 1,050), WXGA+ (1,440 x 900), WXGA (1,280 x 800, 1,280 x 768), UXGA (1,600 x 1,200), SXGA+ (1,400 x 1,050), SXGA (1,280 x 1,024), XGA (1,024 x 768), SVGA (800 x 600), VGA (640 x 480)
<b>Video Compatibility</b>	NTSC (3.58/4.43), PAL (B/D/G/H/I/M/N), SECAM (B/D/G/K/K1/L), HDTV (720p, 1080i, 1035i), EDTV (480p, 575i), SDTV (480i, 576i)	NTSC (3.58/4.43), PAL (B/D/G/H/I/M/N), SECAM (B/D/G/K/K1/L), HDTV (720p, 1080i, 1035i), EDTV (480p, 575i), SDTV (480i, 576i)	NTSC (3.58/4.43), PAL (B/D/G/H/I/M/N), SECAM (B/D/G/K/K1/L), HDTV (720p, 1080i, 1035i), EDTV (480p, 575i), SDTV (480i, 576i)
<b>Inputs/Outputs</b>	D-sub 15 (RGB) x 2 D-sub 15 (Monitor out) x 1 HDMI V1.3 only for Video x 1 S-Video x 1 Composite Video (RCA) x 1 USB control x 1 Networking LAN (RJ45) x 1 RS-232C (D-sub 9) x 1	D-sub 15 (RGB) x 2 D-sub 15 (Monitor out) x 1 HDMI V.1.3 only for Video x 1 S-Video x 1 Composite Video (RCA) x 1 USB control x1 Networking LAN (RJ45) x 1 RS-232C (D-sub 9) x 1	D-sub 15 (RGB) x 1 D-sub 15 (RGB) selectable x 1 HDMI (Digital RGB) x 1 S-Video x 1 Composite Video (RCA) x 1 RCA (white/red) x 1 Networking LAN (RJ45) x 1 RS-232C (D-sub 9) x 1 Stereo mini-jack x 1
<b>Color</b>	Silver	Silver	Silver
<b>Security</b>	Kensington Lock, Security cable bar option, pin code security, remote control operated only	Kensington Lock, Security cable bar option, pin code security, remote control operated only	Kensington Lock, Security cable bar option, pin code security, remote control operated only
<b>On-screen Menu</b>	Arabic, Chinese (Simplified), Chinese (Traditional), Czech, Dutch, English, Finnish, French, German, Greek, Hungarian, Italian, Japanese, Korean, Norwegian, Polish, Portuguese, Russian, Spanish, Swedish, Thai, Turkish	Arabic, Chinese (Simplified), Chinese (Traditional), Czech, Dutch, English, Finnish, French, German, Greek, Hungarian, Italian, Korean, Norwegian, Polish, Portuguese, Russian, Spanish, Swedish, Turkish	Arabic, Chinese (Simplified), Chinese (Traditional), Danish, Dutch, English, Finnish, French, German, Hungarian, Italian, Japanese, Kazak, Korean, Norwegian, Polish, Portuguese, Portuguese (Brazilian), Romanian, Russian, Spanish, Swedish, Turkish
<b>Advanced Features</b>	Filter-less 3D Ready Crestron RoomView Express Quick Lamp Access Direct power on/off Closed Caption	Filter-less 3D Ready Crestron RoomView Express Quick Lamp Access Direct power on/off Closed Caption	Long Life Filter – 4000hrs Crestron RoomView Express Cable Management Cover Quick Lamp Access Direct power on/off Closed Caption
<b>Packed Contents List</b>	Projector, Power cord, computer cable (D-sub15 – D-sub15), wireless remote, owner's manual (CD - ROM & Quick Start Guide)	Projector, Power cord, computer cable (D-sub15 – D-sub15), wireless remote, owner's manual (CD - ROM & Quick Start Guide)	Projector, Power cord, computer cable (D-sub15 – D-sub15), wireless remote, owner's manual (CD - ROM & Quick Start Guide)
<b>Pack Weights and Dimensions</b>	<b>Box 1 of 1:</b> 13.5kg (29.7lb) Dimensions: 572mm x 496mm x 310mm (22.5in x 19.5in x 12.2in) Contents: Projector	<b>Box 1 of 1:</b> 4.9kg (10.8lb) Dimensions: 396mm x 341mm x 181mm (15.5in x 13.4in x 7.1in) Contents: Projector	<b>Box 1 of 1:</b> 9.5kg (20.9lb) Dimensions: 510mm x 470mm x 240mm (20in x 18.5in x 9.4in) Contents: Projector

ActivBoard Systems/Boards SS 02/12 V3.0 US

©2012 Promethean Limited. All rights reserved. Promethean Ltd. is owner of a number of trademarks in several jurisdictions across the world. Any third-party product and company names are mentioned for identification purposes only and may be trademarks of their respective owners. <sup>1</sup>Applicable Terms and Conditions for warranty and support available at [www.PrometheanWorld.com/ActivCare](http://www.PrometheanWorld.com/ActivCare). All dimensions +/- 5mm (0.2in). All weights +/- 0.9kg (2lb). Product Specifications are subject to change without notice. [www.PrometheanWorld.com](http://www.PrometheanWorld.com)