

# Promethean Mount System for **ActivBoard 500 Pro**

## Product Specifications

### INTERACTIVE DISPLAY



ActivBoard 500 Pro Mount System with PRM-32 or PRM-35 projector



ActivBoard 500 Pro Mount System with EST-P1 projector



ActivBoard 500 Pro Mount System with UST-P1 projector

### THIS DOCUMENT CONTAINS SPECIFICATIONS FOR

ActivBoard 500 Pro Series Projector Mount System

### DESCRIPTION

The ActivBoard 500 Pro is available in 78", 87" and 95" versions. Please see the ActivBoard 500 Pro Specification Sheet for details.  
The Mount System includes a Cable Wall Box and choice of Extreme Short Throw, Ultra Short Throw, or Short Throw projector.

### SYSTEM OVERVIEW

#### Installation

ActivBoard Mount System is suitable for self-installation. Promethean recommends that all Mount Systems should be installed by a Certified Promethean Installer.  
The Projector Mount and the ActivBoard mount directly to the wall. Refer to the User Manual for guidelines on fixing points. Components supplied and minimum specifications stated have been tested and are required for optimal performance. Use of components not supplied by Promethean or not meeting minimum specifications may impact performance and affect warranty. Contact your Promethean partner or visit [www.PrometheanKB.com](http://www.PrometheanKB.com) for more information.

#### Warranty†

For Promethean Warranty Terms and Conditions please visit: [www.PrometheanWorld.com/ActivCare](http://www.PrometheanWorld.com/ActivCare)

#### Support

Online Support for all Promethean Products available from: [www.PrometheanKB.com](http://www.PrometheanKB.com)

#### Complete System Weight (approx.)

**ActivBoard 578 Pro including:**  
PRM-32 Projector 50.1kg (110.4lb)  
PRM-35 Projector 51.1kg (112.6lb)  
UST-P1 Projector 52.2kg (115lb)  
EST-P1 Projector 56.2kg (123.8lb)

**ActivBoard 587 Pro including:**  
PRM-35 Projector 54.6kg (120.3lb)  
UST-P1 Projector 55.7kg (122.8lb)  
EST-P1 Projector 59.7kg (131.5lb)

**ActivBoard 595 Pro including:**  
PRM-35 Projector 58.6kg (129.1lb)  
UST-P1 Projector 59.7kg (131.6lb)  
EST-P1 Projector 63.7kg (140.4lb)

# Touchboards

205 Westwood Ave, Long Branch, NJ 07740  
Phone: 866-94 BOARDS (26273) / (732)-222-1511  
Fax: (732)-222-7088 | E-mail: [sales@touchboards.com](mailto:sales@touchboards.com)

07/14 V1.1 EN

©2014 Promethean Limited. All rights reserved. Promethean Ltd. is owner of a number of trademarks in several jurisdictions across the world. Any third-party product and company names are mentioned for identification purposes only and may be trademarks of their respective owners. †Applicable Terms and Conditions for warranty and support available at [www.PrometheanWorld.com/ActivCare](http://www.PrometheanWorld.com/ActivCare). All weights and dimensions approximate. Product Specifications are subject to change without notice. [www.PrometheanWorld.com](http://www.PrometheanWorld.com)



# Promethean Mount System for **ActivBoard 500 Pro**

## Product Specifications

INTERACTIVE DISPLAY

### TECHNICAL DRAWING SPECIFICATIONS

ActivBoard 500 Pro Mount System with PRM-32 or PRM-35 projector

	PRM-35 or PRM-32 - 578 Pro	PRM-35 - 587 Pro	PRM-35 - 595 Pro
ActivBoard 'A'	1768 (69.6")	2105 (82.9")	2335 (92")
Projector 'B'	1347 (53")	1347 (53")	1367 (53.8")
Throw distance 'C'	985 (38.8")	985 (38.8")	1100 (43.3")
Wall box 'D' ± 150 (6")	660 (26")	660 (26")	660 (26")
Fixing height 'E'	810 (31.9")	810 (31.9")	830 (32.7")
Total height 'F'	2270 (81.5")	2270 (81.5")	2290 (90.2")
Min room height 'G'	2280 (81.9")	2280 (81.9")	2300 (90.6")

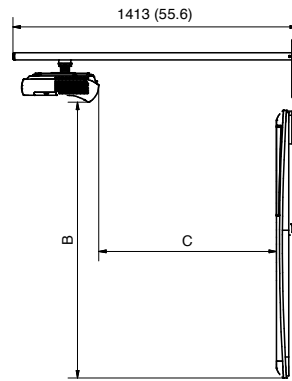
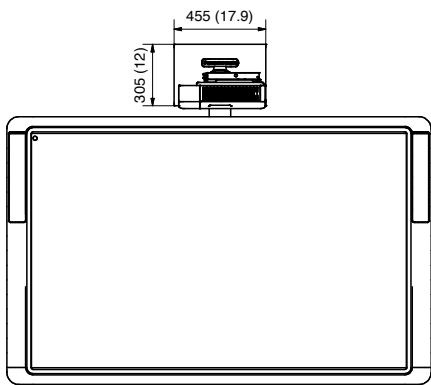
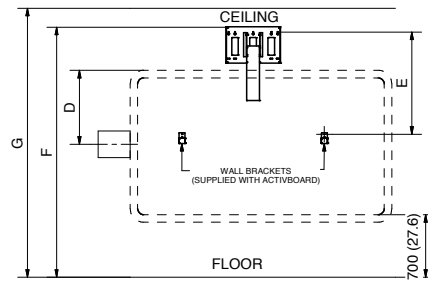
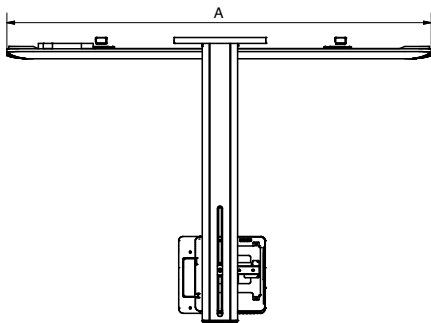

07/14 V1.1 EN



©2014 Promethean Limited. All rights reserved. Promethean Ltd. is owner of a number of trademarks in several jurisdictions across the world. Any third-party product and company names are mentioned for identification purposes only and may be trademarks of their respective owners. †Applicable Terms and Conditions for warranty and support available at [www.PrometheanWorld.com/ActivCare](http://www.PrometheanWorld.com/ActivCare). All weights and dimensions approximate. Product Specifications are subject to change without notice. [www.PrometheanWorld.com](http://www.PrometheanWorld.com)

INTERACTIVE DISPLAY

### TECHNICAL DRAWING SPECIFICATIONS

ActivBoard 500 Pro Mount System with EST-P1 projector

	EST-P1 - 578 Pro	EST-P1 - 587 Pro	EST-P1 - 595 Pro
ActivBoard 'A'	1868 (73.5")	2105 (82.9")	2335 (92")
Projector 'B'	1379 (54.3")	1379 (54.3")	1409 (55.5")
Wall box 'C' ± 150 (6")	660 (26")	660 (26")	660 (26")
Fixing height 'D'	920 (36.2")	920 (36.2")	950 (37.4")
Total height 'E'	2380 (93.7")	2380 (93.7")	2410 (94.9")
Min room height 'F'	2390 (94.1")	2390 (94.1")	2420 (95.3")

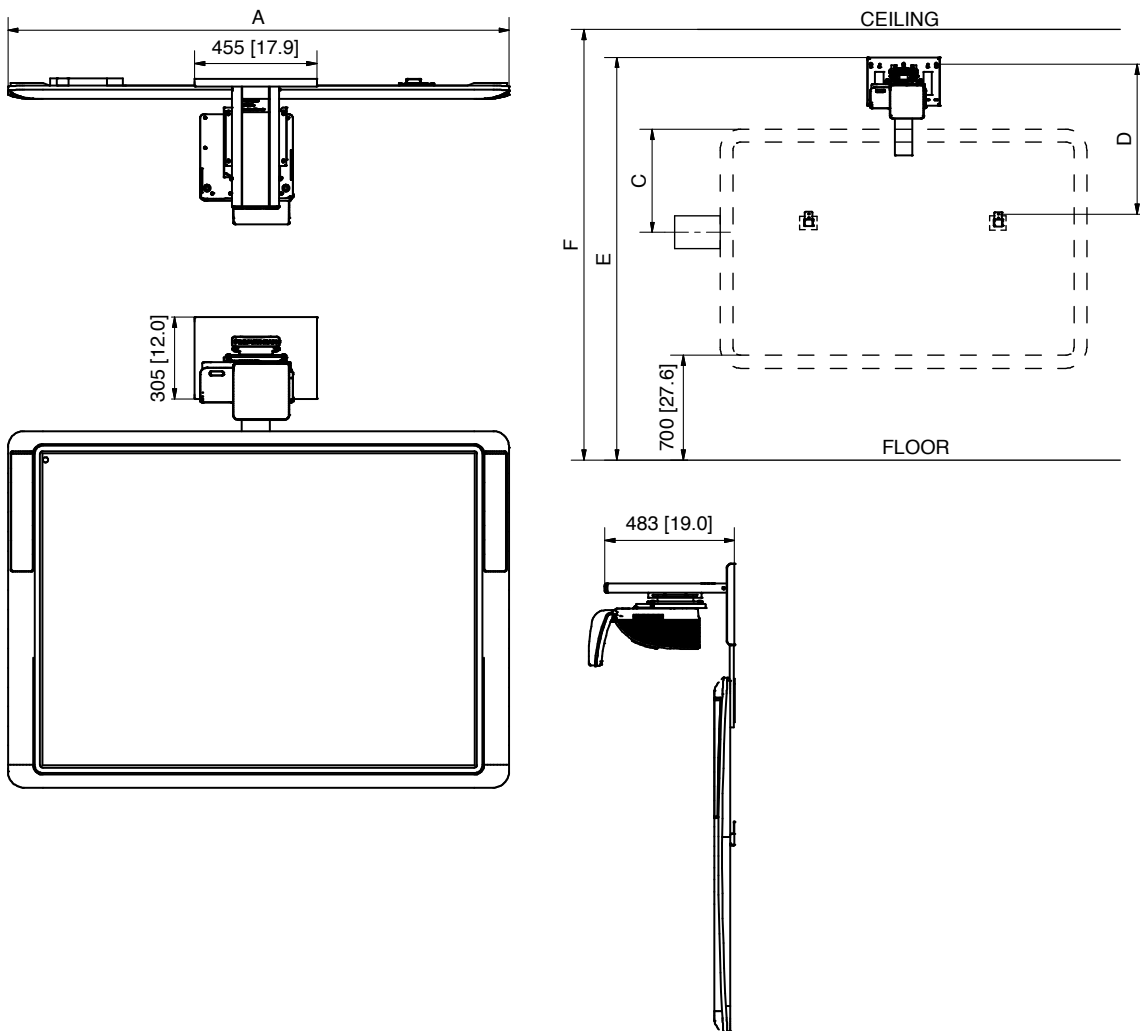

07/14 V1.1 EN

©2014 Promethean Limited. All rights reserved. Promethean Ltd. is owner of a number of trademarks in several jurisdictions across the world. Any third-party product and company names are mentioned for identification purposes only and may be trademarks of their respective owners. †Applicable Terms and Conditions for warranty and support available at [www.PrometheanWorld.com/ActivCare](http://www.PrometheanWorld.com/ActivCare). All weights and dimensions approximate. Product Specifications are subject to change without notice. [www.PrometheanWorld.com](http://www.PrometheanWorld.com)

# Promethean Mount System for **ActivBoard 500 Pro** Product Specifications

INTERACTIVE DISPLAY

## TECHNICAL DRAWING SPECIFICATIONS

ActivBoard 500 Pro Mount System with UST-P1 projector

	UST-P1 - 578 Pro	UST-P1 - 587 Pro	UST-P1 - 595 Pro
ActivBoard 'A'	1866 (73.5")	2105 (82.9")	2335 (92")
Projector 'B'	1480 (58.3)	1440 (56.7")	1528 (60")
Throw distance 'C'	368 (14.5")	337 (13.3")	418 (16")
Wall box 'D' ± 150 (6")	660 (26")	660 (26")	660 (26")
Fixing height 'E'	893 (35.1")	893 (35.1")	983 (39")
Total height 'F'	2344 (92.3")	2304 (90.7")	2436 (95.6")
Min room height 'G'	2354 (92.7")	2314 (91.1")	2446 (96.3")

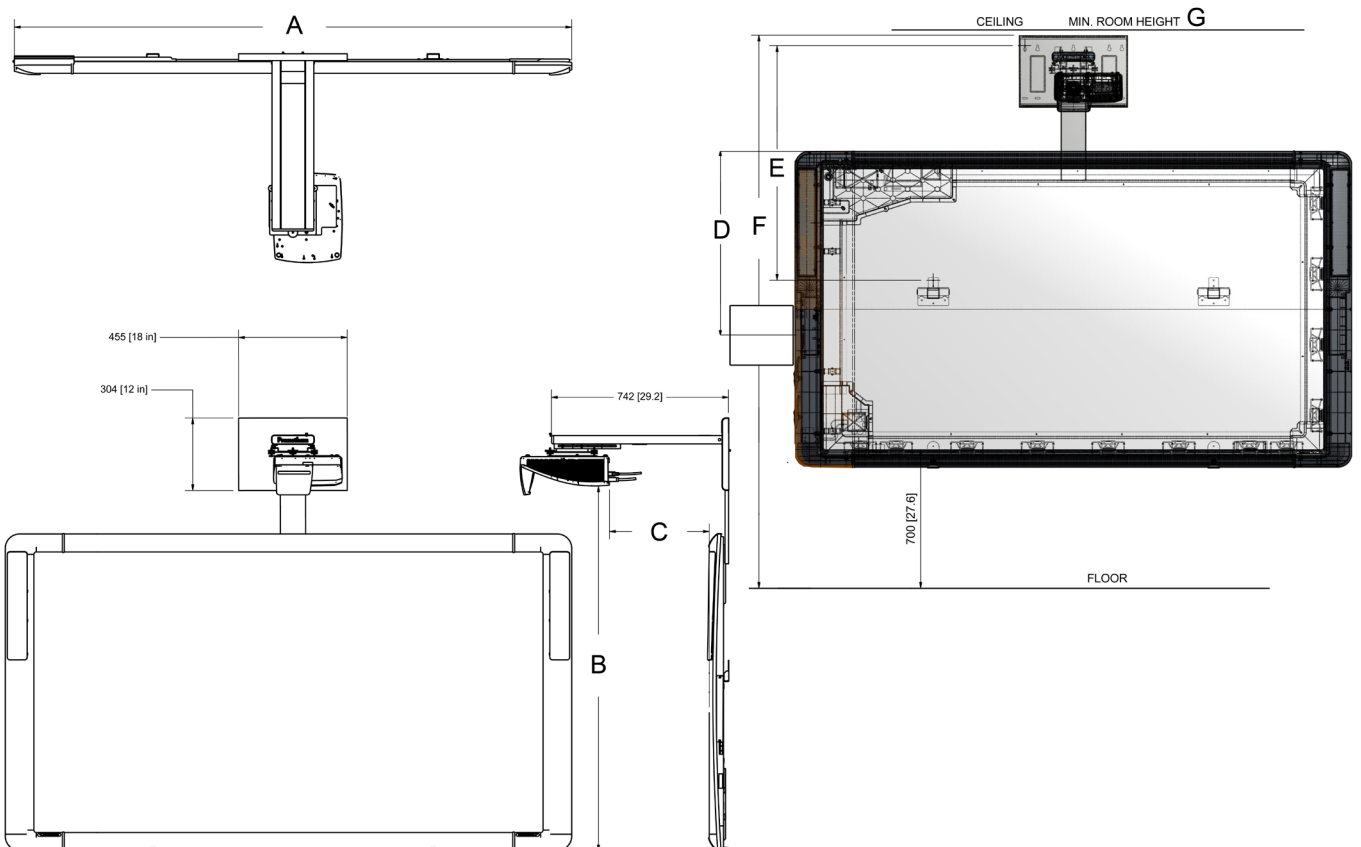

# Touchboards

205 Westwood Ave, Long Branch, NJ 07740  
 Phone: 866-94 BOARDS (26273) / (732)-222-1511  
 Fax: (732)-222-7088 | E-mail: sales@touchboards.com

07/14 V1.1 EN



©2014 Promethean Limited. All rights reserved. Promethean Ltd. is owner of a number of trademarks in several jurisdictions across the world. Any third-party product and company names are mentioned for identification purposes only and may be trademarks of their respective owners. †Applicable Terms and Conditions for warranty and support available at [www.PrometheanWorld.com/ActivCare](http://www.PrometheanWorld.com/ActivCare). All weights and dimensions approximate. Product Specifications are subject to change without notice. [www.PrometheanWorld.com](http://www.PrometheanWorld.com)