

ActivPanel Height-Adjustable Stands

INTERACTIVE FLAT PANEL STAND OPTIONS

PRODUCT SPECIFICATIONS

The ActivPanel Height-Adjustable Stands are a perfect solution to move the ActivPanel up and down effortlessly. Designed with a shielded spring-based system and no power requirements, the Height-Adjustable Stands are maintenance free and an ideal fit for the classroom.

Height-Adjustable Wall Mount Specifications

Compatible with ActivPanel 65", 70", 75", 86" and ActivPanel i-Series 65", 75"



PHYSICAL SPECIFICATIONS

Wall Mount for 65", 70", 75", 86" Sizes

Product Dimensions	556 x 592 x 81 mm (21.9 x 23.3 x 3.2 in)
Packed Dimensions	620 x 670 x 95 mm (24.4 x 26.4 x 3.7 in)
Net Weight	21.6 kg (48 lbs)
Packed Weight	24 kg (53 lbs)
Travel Distance (Adjustable Height)	400 mm (15.7 in)

PACKED CONTENTS

What's in the Box	Box 1 of 1: ActivPanel height-adjustable wall mount, mounting bar, wall frame cover, screw kit, side covers, installation guide, (Vesa mount required is included with ActivPanel. It is not included with ActivPanel i-Series and needs to be purchased separately.)
-------------------	---

ADDITIONAL REQUIREMENTS

Users of the ActivPanel i-Series 65" and 75" need to purchase Vesa mount (AP-WALLMNT).

ActivPanel Height-Adjustable Stands

PRODUCT SPECIFICATIONS

Wall Mount Accessories

The floor support accessory is required for schools that have thin walls or drywalls to ensure proper support for the ActivPanel.*

Height-Adjustable Wall Mount Floor Support Specifications

Compatible with ActivPanel 65", 70", 75", 86" and ActivPanel i-Series 65", 75"



PHYSICAL SPECIFICATIONS

Floor Support for 65", 70", 75" , 86" Sizes

Product Dimensions	650 x 2007 x 46 mm (25.6 x 79 x 1.8 in)
Packed Dimensions	145 x 1070 x 72 mm (5.7 x 42.1 x 2.8 in)
Net Weight	11 kg (24 lbs)
Packed Weight	11.4 kg (25 lbs)

PACKED CONTENTS

What's in the Box	Box 1 of 1: Frame assembly, screw kit, cover strips for floor support legs, installation guide
-------------------	--

*Consult your local building guidelines prior to installation.

ActivPanel 2018 Height-Adjustable Stands SS 06/18 v2.8 EN

Page 2

Height-Adjustable Mobile Stand Specifications

Compatible with ActivPanel 65", 70", 75" and ActivPanel i-Series 65", 75"



PHYSICAL SPECIFICATIONS

Mobile Stand for 65", 70", 75" Sizes

Product Dimensions	1196 x 1803 x 876 mm (47.1 x 71 x 34.5 in)
Packed Dimensions	Box 1 of 2 (Mobile Stand): 945 x 1735 x 180 mm (37.2 x 68.3 x 7.1 in) Box 2 of 2 (Height-Adjustable Mount): 630 x 740 x 95 mm (24.8 x 29.1 x 3.7 in)
Net Weight	Box 1 of 2 (Mobile Stand): 42.5 kg (94 lbs) Box 2 of 2 (Height-Adjustable Mount): 21.6 kg (47.6 lbs)
Packed Weight	Box 1 of 2 (Mobile Stand): 48.5 kg (107 lbs) Box 2 of 2 (Height-Adjustable Mount): 24 kg (52.9 lbs)
Travel Distance (Adjustable Height)	400 mm (15.7 in)

PACKED CONTENTS

What's in the Box	Box 1 of 2: Mobile stand base, mobile stand frame, castors, screw kit, installation guide Box 2 of 2: Height-adjustable mount (Vesa mount required is included with ActivPanel. It is not included with ActivPanel i-Series and needs to be purchased separately.)
-------------------	---

ADDITIONAL REQUIREMENTS

Users of the ActivPanel i-Series 65" and 75" need to purchase Vesa mount (AP-WALLMNT)

WARRANTY

Three-Year Warranty. For more information, visit PrometheanWorld.com/ActivCare.

INSTALLATION

The installation of this product should be completed by a qualified installer. Use of components not supplied by Promethean or not meeting minimum specifications may impact performance, safety and warranty. For more information, visit Support.PrometheanWorld.com.

COMPLIANCE & CERTIFICATION

Regulatory Certification CE LVD, CB, UL, CUL

SUPPORT

For all Promethean products, visit Support.PrometheanWorld.com.

TECHNICAL DRAWINGS

Height-Adjustable Wall Mount for 65", 70", 75" , 86" Sizes

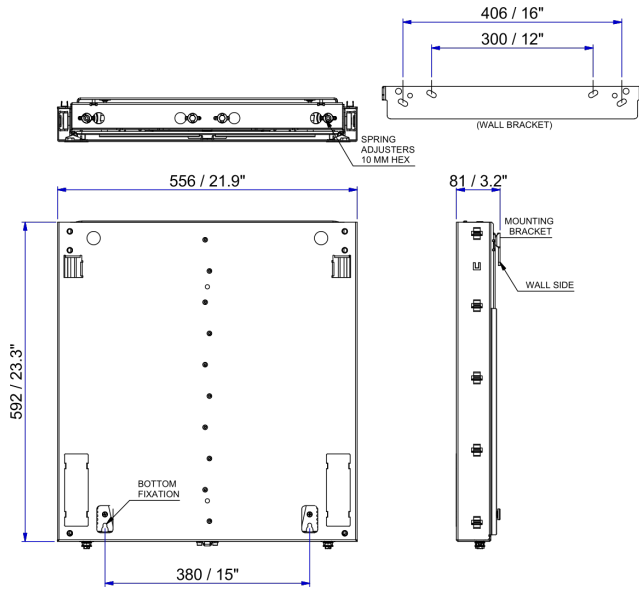

Height-Adjustable Wall Mount Floor Support for 65", 70", 75", 86" Sizes

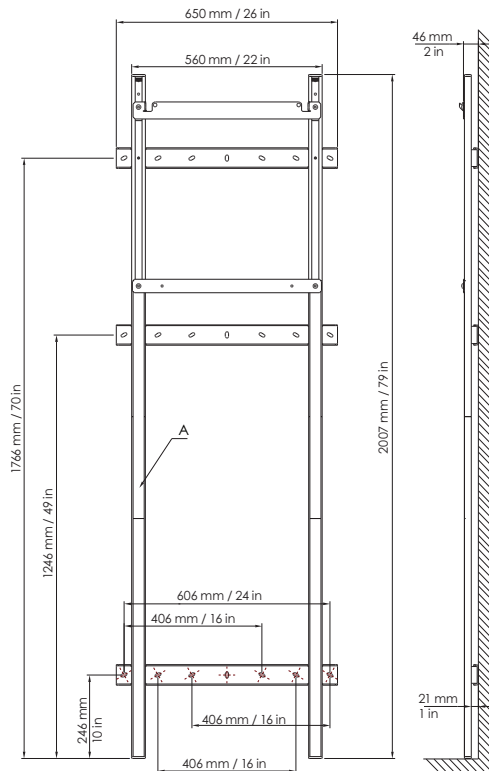

TECHNICAL DRAWINGS

Height-Adjustable Mobile Stand for 65", 70", 75" Sizes

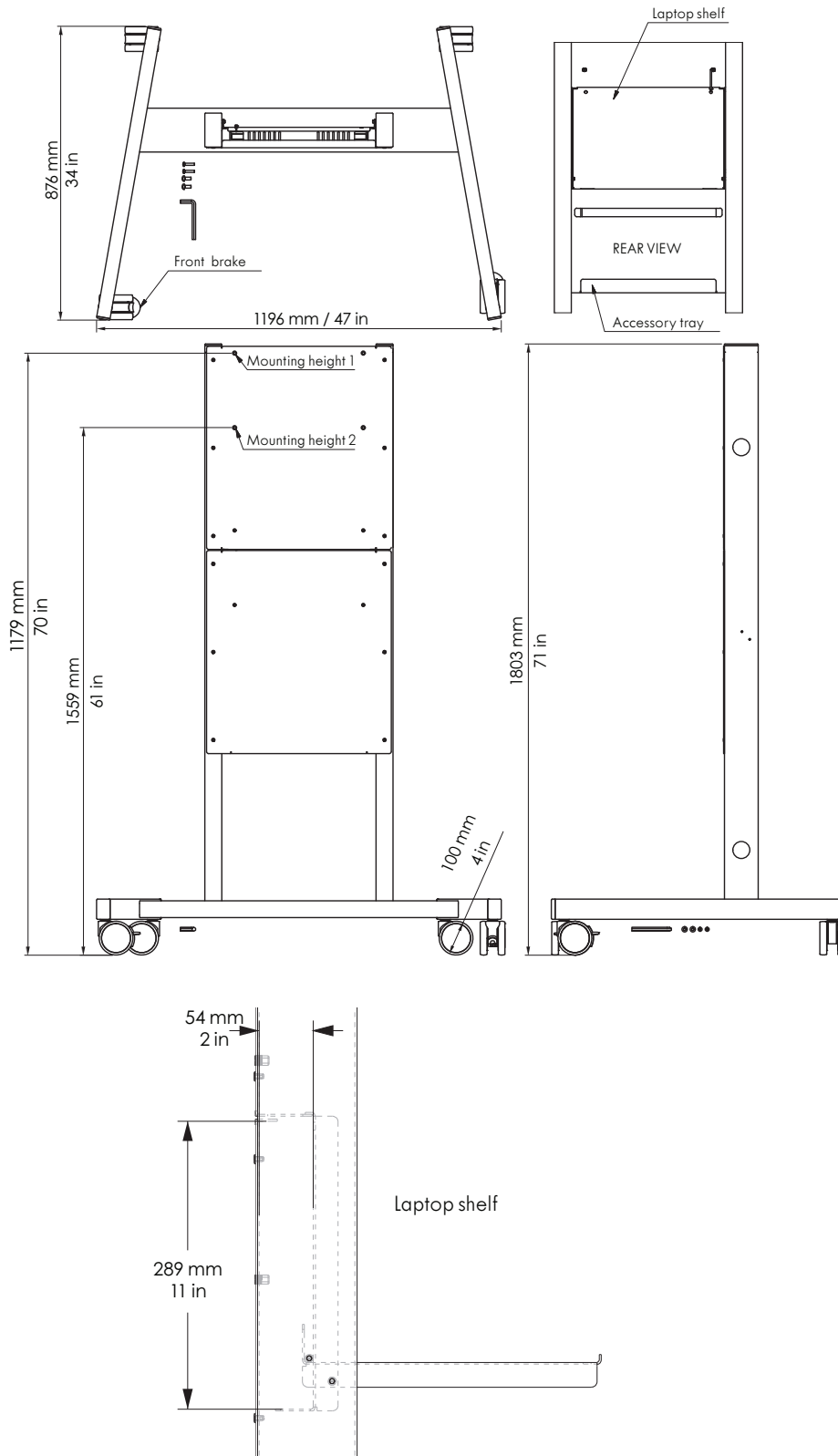

ActivPanel 2018 Height-Adjustable Stands SS 06/18 v2.8 EN